

2016

www.akko.com.tr

konuşulan
the spoken kalite...
quality...





konusulan
the spoken kalite...
quality...





1986 yılında Abdullah KARAKUŞ tarafından kurulan AKKO Oto. Mak. Hırd. San. Tic. Ltd. Şti. Tornalama Takımlarını, Diş ve Kanal Açma Takımlarını, Delik Delme Takımlarını, Frezeleme Takımlarını ve Özel Takımları üretmektedir. Şu an 8000 m²' ye yakın bir alanda Türkiye, Japonya, Almanya, İsveç gibi ülkelerin ürettikleri son teknoloji tezgah ve ekipmanlarıyla yıllık 300.000 adet üretim kapasitesiyle, standart 5000 çeşit takım üretimi yapmaktadır. Avrupa, Asya, Afrika, Güney Amerika ve Orta Doğu Ülkeleri olmak üzere şimdilik 60 ülkeye mal sevkiyatına devam etmekte olup 200.000 adet civarında üretilmiş ürün stoklarında mevcuttur. Firmaya, özel üretilen çelik hammadde işleme girer ve bütün üretim süreci bünyesinde gerçekleşir. Çeliğin işlenmesine, ısıl işlemine, üzerindeki kaplama ve her türlü işlem bir entegre tesis olan AKKO'da gerçekleşir.



We as AKKO Oto. Mak. Hird. San. Tic. Ltd. Şti, which has been founded by Abdullah KARAKUŞ in 1986, produce Turning Tool Holders, Threading and Grooving Tool Holders, U-Drills, Milling Tool Holders and Precision Tool Holders (OEM Tool Holders). We produce standard 5000 kinds of tool holders with production capacity of 300.000 pieces per annum in an area about 8000 square meter. we are going on exporting 60 countries including European, Asian, African, Asian, South American Countries and Middle East Countries. We keep ready about 200.000 pieces produced products in our stock. Steel Raw materials that we make produced especially for us are delivered our factory and all production process are made in our factory. All kind of process from machining of steel to heat treatment and coating on our tools are made in our integrated factory AKKO.

	DIŞ TORNA TAKIMLARI
S9	DIŞ TORNA KATERLERİ KODLAMA SİSTEMİ
S10-S19	T-SİSTEM DIŞ TORNA KATERLERİ
S20-S22	M-SİSTEM DIŞ TORNA KATERLERİ
S23-S31	P-SİSTEM DIŞ TORNA KATERLERİ
S32-S37	C-SİSTEM DIŞ TORNA KATERLERİ
S38-S50	S-SİSTEM DIŞ TORNA KATERLERİ
S51-S54	S-SİSTEM İSVEÇ TİPİ KAYAR OTOMAT MAKİNA TAKIMLARI

	DELİK TORNA TAKIMLARI
S56	DELİK TORNA KATERLERİ KODLAMA SİSTEMİ
S57-S62	T&C SİSTEM DELİK TORNA KATERLERİ
S63-S67	M-SİSTEM DELİK TORNA KATERLERİ
S68-S73	P-SİSTEM DELİK TORNA KATERLERİ
S74-S85	S-SİSTEM DELİK TORNA KATERLERİ

	KARTUŞLAR
S87	KARTUŞLARIN KODLAMA SİSTEMİ
S88-S89	S-TİP HONLAMA KARTUŞLARI
S90-S93	S-SİSTEM KARTUŞLAR

	DIŞ AÇMA TAKIMLARI
S95	DIŞ AÇMA KATERLERİ KODLAMA SİSTEMİ
S96-S99	DIŞ AÇMA KATERLERİ ve TEKNİK BİLGİ

	KANAL AÇMA TAKIMLARI
S103	KANAL KATERLERİ KODLAMA SİSTEMİ
S104-S115	DIŞ ÇAP KANAL AÇMA TAKIMLARI
S116	DIŞ ÇAP KANAL AÇMA İSVEÇ TİPİ KAYAR OTOMAT MAKİNA TAKIMLARI
S117-S119	DIŞ ÇAP ALIN KANAL AÇMA TAKIMLARI
S120	L TİP ALIN KANAL AÇMA TAKIMLARI
S121	KESME VE DERİN KANAL AÇMA LAMALARI
S121	KESME VE DERİN KANAL AÇMA LAMA BLOĞU
S122-S128	DELİK İÇİ KANAL KATERLERİ

	DELİK DELME ve İŞLEME TAKIMLARI
S131-S146	TAKMA UÇLU MATKAPLAR ve KODLAMA SİSTEMİ
S147	EKSANTRİK U-DRILL ADAPTÖRÜ
S148-S150	EKONOMİK KESİCİLER ve KODLAMA SİSTEMİ
S151-S154	AYARLI DELİK İŞLEME BARALARI ve KODLAMA SİSTEMİ

	FREZELEME TAKIMLARI
S156	FREZELEME TAKIMLARI KODLAMA SİSTEMİ
S157-S158	S-SİSTEM PAH FREZELER
S158	SİLİNDİRİK ALYAN BAŞLI VİDA (DIN 974-1) HAVŞALARINI AÇMA FREZELERİ
S159-S174	S-SİSTEM YÜZEY PARMAK FREZELER
S175-S176	S-SİSTEM YÜZEY ve KOPYA PARMAK FREZELER
S177-S180	S-SİSTEM HIZLI İLERLEMELİ PARMAK FREZELER
S181-S186	S-SİSTEM MODÜLER PARMAK FREZELER
S187-S189	S-SİSTEM HIZLI İLERLEMELİ MODÜLER PARMAK FREZELER
S190	KÜRE UÇLU PARMAK FREZELER
S191-S192	VİDALI KÜRE UÇLU PARMAK FREZELER
S192	VİDALI TAKIM TUTUCULARI
S193	DIŞ AÇMA FREZELEME TAKIMLARI
S194	S-SİSTEM HELİS FREZELER
S195-S212	YÜZEY FREZELER
S213-S216	YÜZEY ve KOPYA FREZELER
S217-S218	C-SİSTEM YÜZEY FREZELER
S219-S222	HIZLI İLERLEMELİ FREZELER
S223-S224	T KANAL FREZELER
S225-S226	DİSK FREZELER
S227-S229	FREZELEME TAKIMLARI MONTAJ ÖLÇÜLERİ ve TEKNİK BİLGİLER

	YEDEK PARÇALAR
S230-S243	YEDEK PARÇALAR

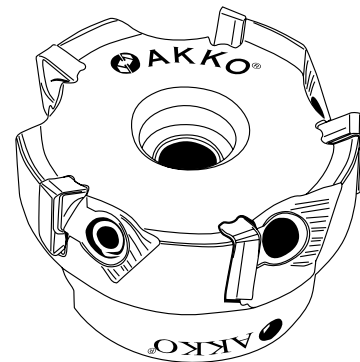
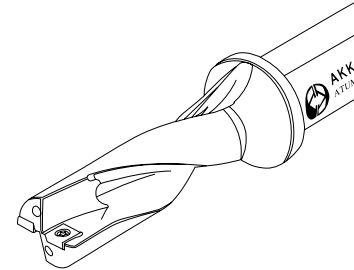
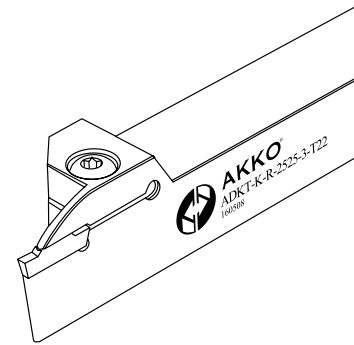
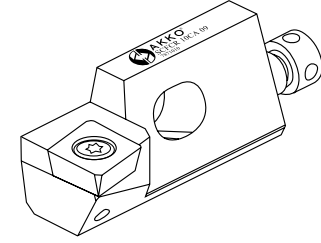
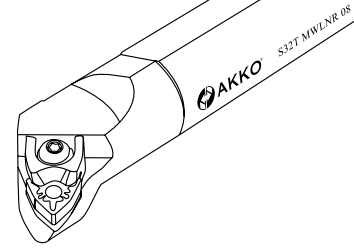
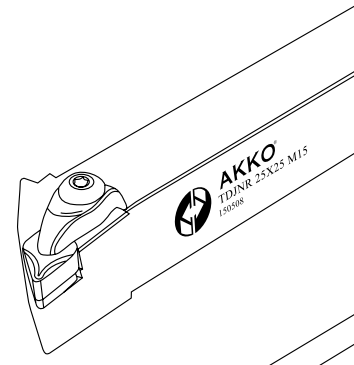

İÇİNDEKİLER

CONTENTS

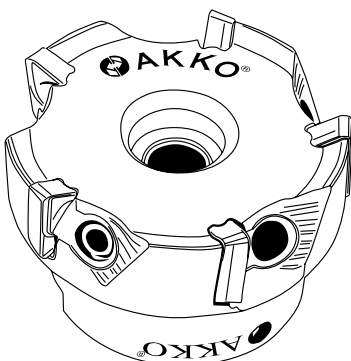
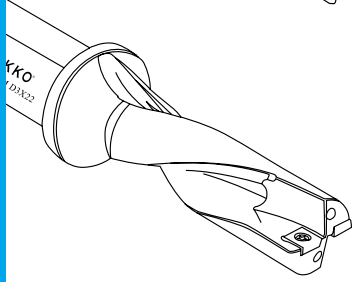
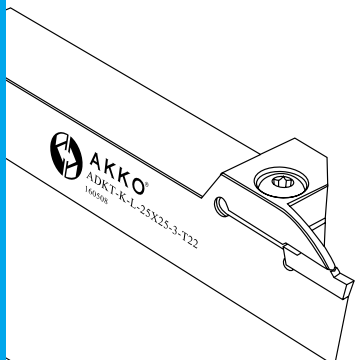
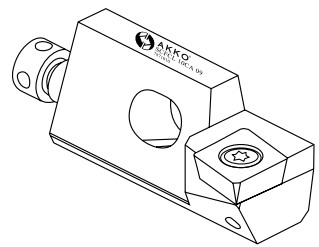
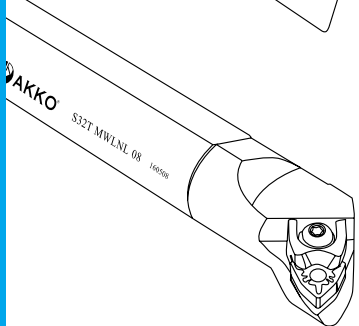
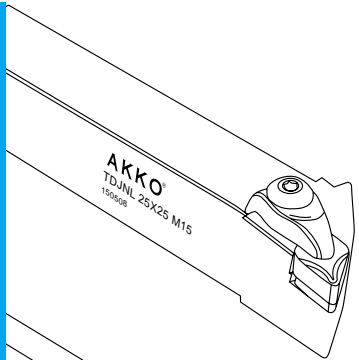

	EXTERNAL TURNING TOOLHOLDERS
P9	EXTERNAL TURNING TOOLHOLDERS DESIGNATION SYSTEM
P10-P19	T-SYSTEM EXTERNAL TURNING TOOLHOLDERS
P20-P22	M-SYSTEM EXTERNAL TURNING TOOLHOLDERS
P23-P31	P-SYSTEM EXTERNAL TURNING TOOLHOLDERS
P32-P37	C-SYSTEM EXTERNAL TURNING TOOLHOLDERS
P38-P50	S-SYSTEM EXTERNAL TURNING TOOLHOLDERS
P51-P54	S-SYSTEM TOOLS FOR SWISS TYPE SLIDING AUTOMATIC LATHES

	INTERNAL TURNING TOOLHOLDERS
P56	BORING BARS DESIGNATION SYSTEM
P57-P62	T&C SYSTEM BORING BARS
P63-P67	M-SYSTEM BORING BARS
P68-P73	P-SYSTEM BORING BARS
P74-P85	S-SYSTEM BORING BARS

	CARTRIDGE
P87	CARTRIDGE DESIGNATION SYSTEM
P88-P89	S-TYPE HONING CARTRIDGE
P90-P93	S-SYSTEM CARTRIDGE

	THREADING TOOLHOLDERS
P95	THREADING TOOLHOLDERS DESIGNATION SYSTEM
P96-P99	THREADING TOOLHOLDERS and TECHNICAL INFORMATION

	GROOVING TOOLHOLDERS
P103	GROOVING TOOLHOLDERS DESIGNATION SYSTEM
P104-P115	EXTERNAL GROOVING TOOLHOLDERS
P116	EXTERNAL GROOVING TOOLHOLDERS FOR SWISS TYPE SLIDING AUTOMATIC LATHES
P117-P119	FACE EXTERNAL GROOVING TOOLHOLDERS
P120	L TYPE FACE EXTERNAL GROOVING TOOLHOLDERS
P121	BLADES FOR PARTING AND DEEP GROOVING
P121	BLOCKS FOR PARTING AND DEEP GROOVING BLADES
P122-P128	INTERNAL GROOVING TOOLHOLDERS

	DRILLING and HOLEMAKING TOOLS
P131-P146	U-DRILL SYSTEM and DESIGNATION SYSTEM
P147	EXCENTRIC ADAPTOR FOR U-DRILLS
P148-P150	ECONOMIC CUTTING TOOLS and DESIGNATION SYSTEM
P151-P154	ADJUSTABLE BORING HEADS and DESIGNATION SYSTEM

	MILLING TOOLS
P156	MILLING TOOLS DESIGNATION SYSTEM
P157-P158	S-SYSTEM CHAMFERING END MILLS
P158	COUNTERSINK MILLING TOOL FOR CYLINDRICAL ALLEN HEAD SCREWS (DIN 974-1)
P159-P174	S-SYSTEM END MILLS
P175-P176	S-SYSTEM FACE and COPY END MILLS
P177-P180	S-SYSTEM HIGHFEED END MILLS
P181-P186	S-SYSTEM MODULAR END MILLS (SCREW TYPE TOOLS)
P187-P189	S-SYSTEM MODULAR (SCREW TYPE) HIGHFEED END MILLS
P190	BALL NOSE MILLS
P191-P192	BALL NOSE MODULAR (SCREW TYPE) END MILLS
P192	SCREWED TOOL HOLDERS
P193	THREAD MILLING TOOLS
P194	S-SYSTEM HELIX END MILL
P195-P212	FACE MILLING
P213-P216	FACE and COPY MILLING TOOLS
P217-P218	C-SYSTEM FACE MILLING
P219-P222	HIGH FEED MILLING TOOLS
P223-P224	T SLOT MILLING
P225-P226	DISC MILLING
P227-P229	MOUNTING REFERENCE FOR MILLING CUTTERS and TECHNICAL INFORMATION

	SPARE PARTS
P230-P243	SPARE PARTS



DIŐ TORNALAKIMLARI
EXTERNAL TURNING TOOLHOLDERS





P **S** **K** **N** **R**

1 2 3 4 5

1 Sıkma Tipi / Method of Mounting of Insert

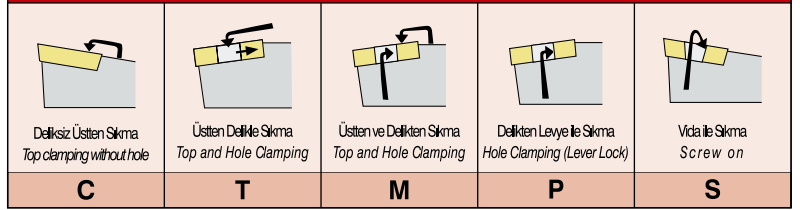

2 Uç Tipi / Insert Shape

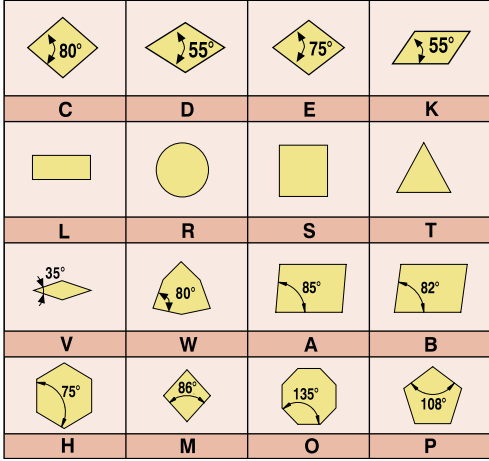

3 Yanaşma Açısı / ToolHolder Shape

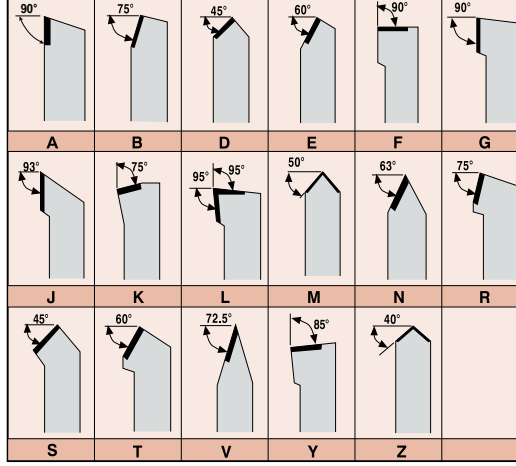

4 Serbest Uç Açısı / Clearance angle of Insert

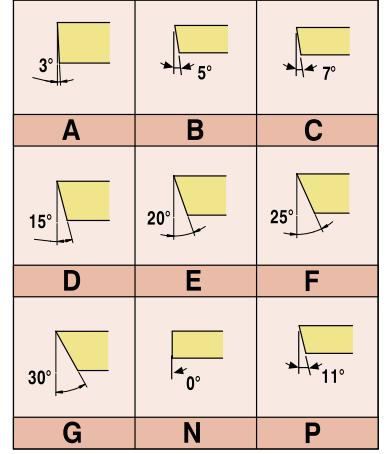

25 **25** - **M** **12** **C**

6 7 8 9 10

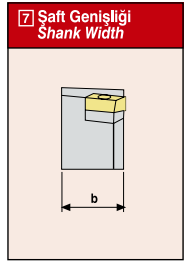
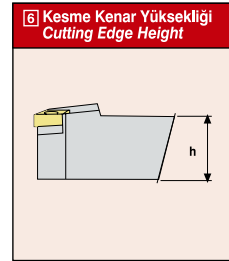
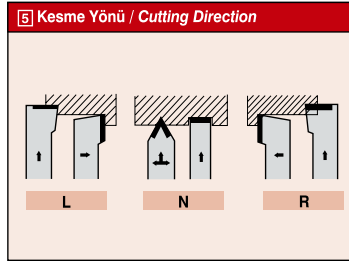

8 Şaft Boyu / Shank Length

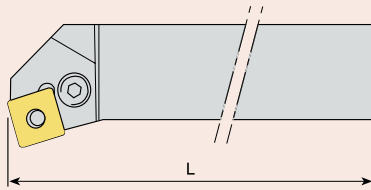

A - 32	H - 100	Q - 180	x-special
B - 40	J - 110	R - 200	
C - 50	K - 125	S - 250	
D - 60	L - 140	T - 300	
E - 70	M - 150	U - 350	
F - 80	N - 160	V - 400	
G - 90	P - 170	W - 450	

9 Kesme Kenar Uzunluğu / Cutting Edge Length

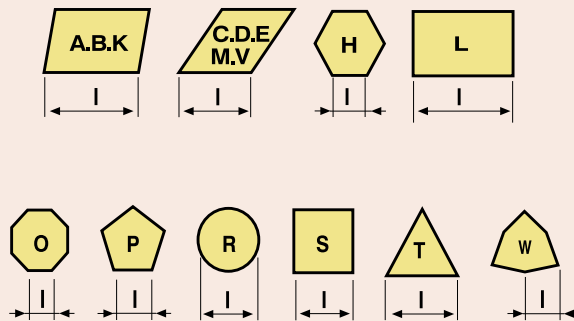

10 Baskı Pabucu / Wedge Clamp

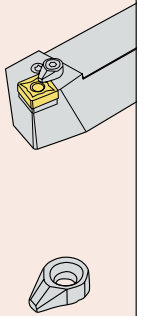



*konusulan
the spoken kalite...
quality...*

T-SİSTEM

T-SİSTEM DIŞ TORNA KATERLERİ

T-SYSTEM EXTERNAL TURNING TOOLHOLDERS



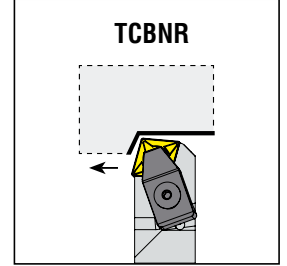
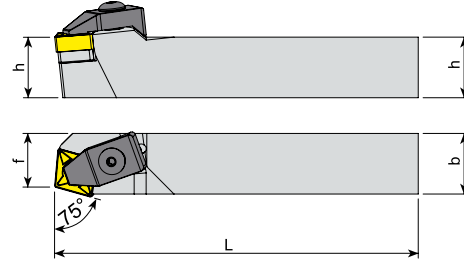

Takım Kodu Ordering Code	Stok Stock		Takım Ölçüleri (mm) Dimension (mm)				Kesici Uç Insert	Yedek Parçaları Spare Parts						
	R	L	h	b	L	f		Baskı Pabucu Wedge Clamp	Pabuç Vidası Clamp Screw	Altık Shim	Altık Vidası Shim Screw	Yay Spring	Pul Stamp	Anahtar Allen Key
	TCBNR/L 2525 M16	●	●	25	25	170		22						-

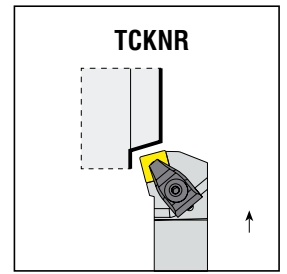
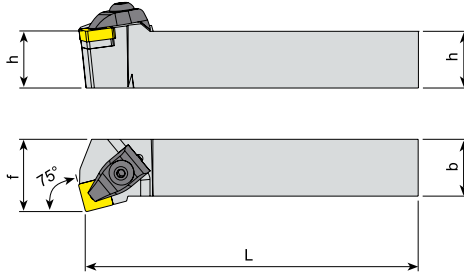

Takım Kodu Ordering Code	Stok Stock		Takım Ölçüleri (mm) Dimension (mm)				Kesici Uç Insert	Yedek Parçaları Spare Parts						
	R	L	h	b	L	f		Baskı Pabucu Wedge Clamp	Pabuç Vidası Clamp Screw	Altık Shim	Altık Vidası Shim Screw	Yay Spring	Pul Stamp	Anahtar Allen Key
	TCKNR/L 2020 K12	●	●	20	20	125		25						
2525 M12	●	●	25	25	150	32	CNM. 1204..	ATK-02	AKV-02-M6x22	AACN-3-0001	AAV-02-M5x12	AKY-01	ABPL-01	AAL-03-3
3232 P12	●	●	32	32	170	40								
2525 M16	●	●	25	25	150	32	CNM. 1606..	ATK-04	AKV-19-M7x25	AACN-3-0002	AAV-05-M6x15	-	ABPL-02	AAL-05-4
3232 P16	●	●	32	32	170	40								

R: Sağ/Right L: Sol/Left ● Stokta/In Stock ○ Stokta Yok/Non Stock Item

Sipariş Örneği/Ordering Example : 1 ad./pcs. TCBNR 2525 M16

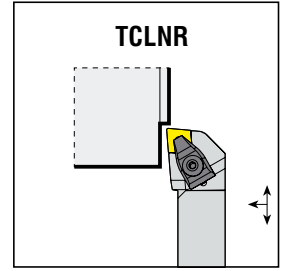
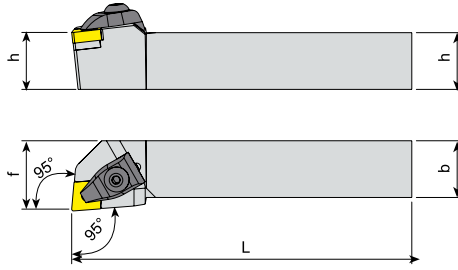

Takım Kodu Ordering Code	Stok Stock		Takım Ölçüleri (mm) Dimension (mm)				Kesici Uç Insert	Yedek Parçaları Spare Parts						
	R	L	h	b	L	f		Baskı Pabucu Wedge Clamp	Pabuç Vidası Clamp Screw	Altık Shim	Altık Vidası Shim Screw	Yay Spring	Pul Stamp	Anahtar Allen Key
TCLNR/L 2020 K12	●	●	20	20	125	25	●	●	●	●	●	●	●	●
2525 M12	●	●	25	25	150	32								
3232 P12	●	●	32	32	170	40								
4040 S12	●	●	40	40	250	50								
5050 S12	●	●	50	50	250	63	●	●	●	●	●	●	●	●
2525 M16	●	●	25	25	150	32								
3232 P16	●	●	32	32	170	40	CNM. 1204..	ATK-02	AKV-02-M6x22	AACN-3-0001	AAV-02-M5x12	AKY-01	ABPL-01	AAL-03-3
							CNM. 1606..	ATK-04	AKV-19-M7x25	AACN-3-0002	AAV-05-M6x15	-	ABPL-02	AAL-05-4

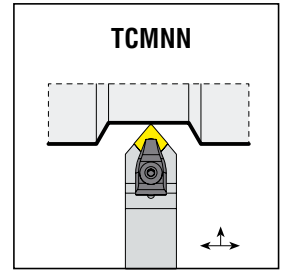
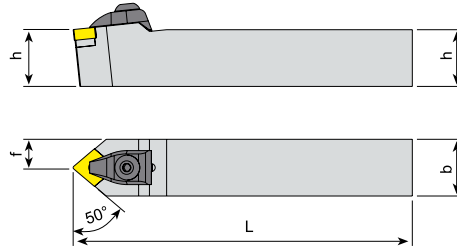

Takım Kodu Ordering Code	Stok Stock		Takım Ölçüleri (mm) Dimension (mm)				Kesici Uç Insert	Yedek Parçaları Spare Parts						
	R	L	h	b	L	f		Baskı Pabucu Wedge Clamp	Pabuç Vidası Clamp Screw	Altık Shim	Altık Vidası Shim Screw	Yay Spring	Pul Stamp	Anahtar Allen Key
TCMNN 1616 H12	●	●	16	16	100	8	●	●	●	●	●	●	●	●
2020 K12	●	●	20	20	125	10								
2525 M12	●	●	25	25	150	12.5								
3232 P12	●	●	32	32	170	16								
2525 M16	●	●	25	25	150	12.5	●	●	●	●	●	●	●	
3232 P16	●	●	32	32	170	16								
4040 S16	○	○	40	40	250	20	CNM. 1204..	ATK-02	AKV-02-M6x22	AACN-3-0001	AAV-02-M5x12	AKY-01	ABPL-01	AAL-03-3
							CNM. 1606..	ATK-04	AKV-19-M7x25	AACN-3-0002	AAV-05-M6x15	-	ABPL-02	AAL-05-4

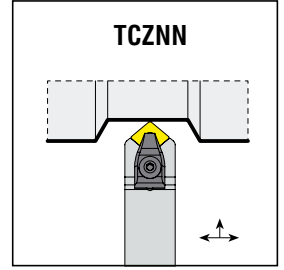
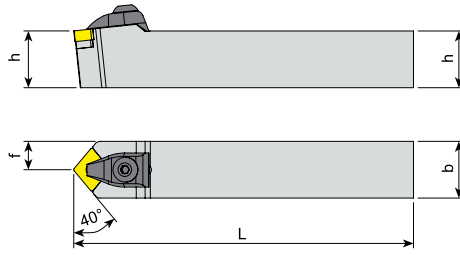

Takım Kodu Ordering Code	Stok Stock		Takım Ölçüleri (mm) Dimension (mm)				Kesici Uç Insert	Yedek Parçaları Spare Parts						
	R	L	h	b	L	f		Baskı Pabucu Wedge Clamp	Pabuç Vidası Clamp Screw	Altlık Shim	Altlık Vidası Shim Screw	Yay Spring	Pul Stamp	Anahtar Allen Key
TCZNN 2020 K12	●		20	20	125	10								
2525 M12	●		25	25	150	12.5								
3232 P12	●		32	32	170	16								
2525 M16	●		25	25	150	12.5						-		
3232 P16	●		32	32	170	16								



107.5°

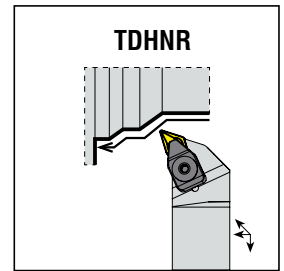
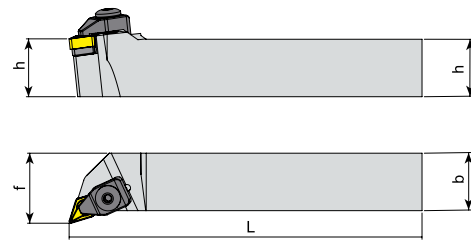

Takım Kodu Ordering Code	Stok Stock		Takım Ölçüleri (mm) Dimension (mm)				Kesici Uç Insert	Yedek Parçaları Spare Parts						
	R	L	h	b	L	f		Baskı Pabucu Wedge Clamp	Pabuç Vidası Clamp Screw	Altlık Shim	Altlık Vidası Shim Screw	Yay Spring	Pul Stamp	Anahtar Allen Key
TDHNR/L 2020 K15	○	○	20	20	125	25								
2525 M15	●	○	25	25	150	32								
3232 P15	○	○	32	32	170	40								

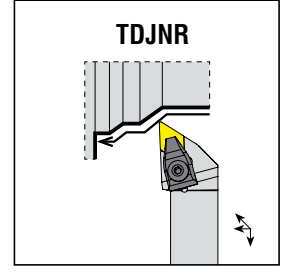
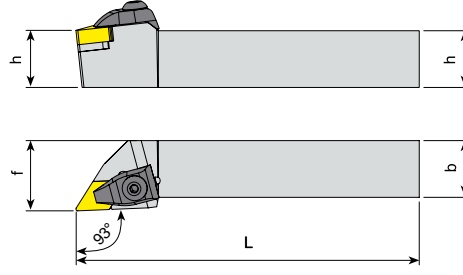

Takım Kodu Ordering Code	Stok Stock		Takım Ölçüleri (mm) Dimension (mm)				Kesici Uç Insert	Yedek Parçaları Spare Parts						
	R	L	h	b	L	f		Baskı Pabucu Wedge Clamp	Pabuç Vidası Clamp Screw	Altılık Shim	Altılık Vidası Shim Screw	Yay Spring	Pul Stamp	Anahtar Allen Key
TDJNR/L 1616 H11	●	●	16	16	100	20	DNM. 1104..							
2020 K11	●	●	20	20	125	25								
2525 M11	●	●	25	25	150	32								
2020 K15	●	●	20	20	125	25	DNM. 1506..							
2525 M15	●	●	25	25	150	32								
3232 P15	●	●	32	32	170	40								
4040 S15	●	●	40	40	250	50								
5050 S15	○	○	50	50	250	63	DNM. 1504..							
2020 K1504	●	●	20	20	125	25								
2525 M1504	●	●	25	25	150	32								
3232 P1504	●	●	32	32	170	40								
4040 S1504	●	●	40	40	250	50								

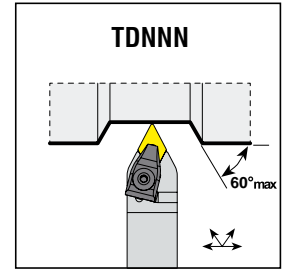
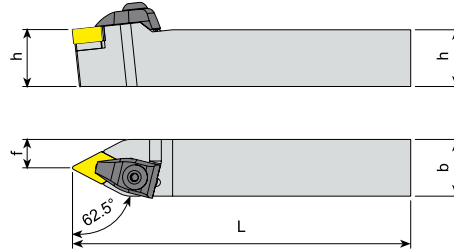

Takım Kodu Ordering Code	Stok Stock		Takım Ölçüleri (mm) Dimension (mm)				Kesici Uç Insert	Yedek Parçaları Spare Parts						
	R	L	h	b	L	f		Baskı Pabucu Wedge Clamp	Pabuç Vidası Clamp Screw	Altılık Shim	Altılık Vidası Shim Screw	Yay Spring	Pul Stamp	Anahtar Allen Key
TDNNN 1616 H11	●	●	16	16	100	8	DNM. 1104..							
2020 K11	●	●	20	20	125	10								
2525 M11	●	●	25	25	150	12.5								
2020 K15	●	●	20	20	125	10	DNM. 1506..							
2525 M15	●	●	25	25	150	12.5								
3232 P15	●	●	32	32	170	16								
4040 S15	○	○	40	40	250	20								
5050 S15	○	○	50	50	250	25								

R: Sağ/Right L: Sol/Left ● Stokta/In Stock ○ Stokta Yok/Non Stock Item

Sipariş Örneği/Ordering Example : 1 ad./pcs. TDJNR 1616 H11

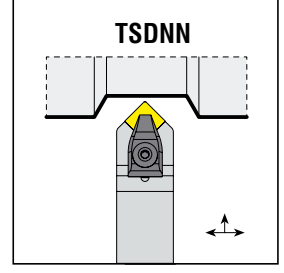
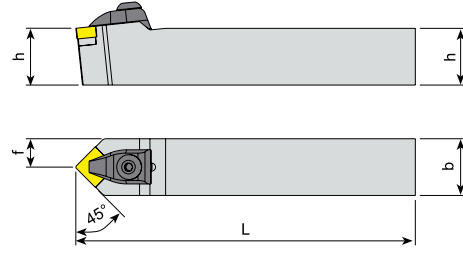

Takım Kodu Ordering Code	Stok Stock	Takım Ölçüleri (mm) Dimension (mm)				Kesici Uç Insert	Yedek Parçaları Spare Parts						
		h	b	L	f		Baskı Pabucu Wedge Clamp	Pabuç Vidası Clamp Screw	Altılık Shim	Altılık Vidası Shim Screw	Yay Spring	Pul Stamp	Anahtar Allen Key
TSDNN 1616 H12	●	16	16	100	8								
2020 K12	●	20	20	125	10								
2525 M12	●	25	25	150	12.5								
3232 P12	●	32	32	170	16								
2525 M15	○	25	25	150	12.5						-		
3232 P15	○	32	32	170	16								
4040 S15	○	40	40	250	20								

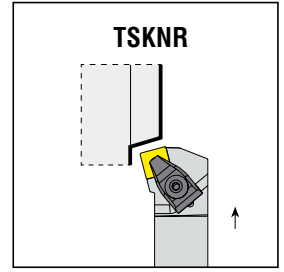
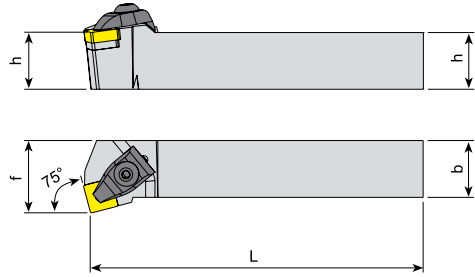

Takım Kodu Ordering Code	Stok Stock	Takım Ölçüleri (mm) Dimension (mm)				Kesici Uç Insert	Yedek Parçaları Spare Parts								
		R	L	h	b		L	f	Baskı Pabucu Wedge Clamp	Pabuç Vidası Clamp Screw	Altılık Shim	Altılık Vidası Shim Screw	Yay Spring	Pul Stamp	Anahtar Allen Key
TSKNR/L 2020 K12	● ●	20	20	125	25										
2525 M12	● ●	25	25	150	32										
3232 P12	● ●	32	32	170	40										
3232 P15	● ●	32	32	170	40										
											-				

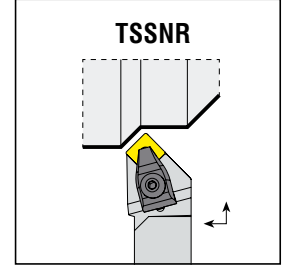
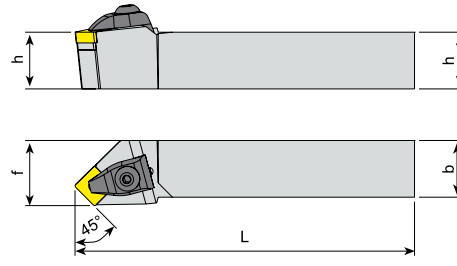

Takım Kodu Ordering Code	Stok Stock		Takım Ölçüleri (mm) Dimension (mm)				Kesici Uç Insert	Yedek Parçaları Spare Parts						
	R	L	h	b	L	f		Baskı Pabucu Wedge Clamp	Pabuç Vidası Clamp Screw	Altlık Shim	Altlık Vidası Shim Screw	Yay Spring	Pul Stamp	Anahtar Allen Key
TSSNR/L 2020 K12	●	●	20	20	125	25								
2525 M12	●	●	25	25	150	32								
3232 P12	●	●	32	32	170	40								
2525 M15	●	●	25	25	150	32								
3232 P15	●	●	32	32	170	40								

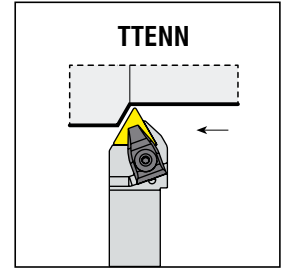
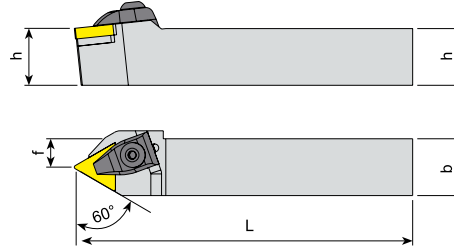

Takım Kodu Ordering Code	Stok Stock		Takım Ölçüleri (mm) Dimension (mm)				Kesici Uç Insert	Yedek Parçaları Spare Parts						
	R	L	h	b	L	f		Baskı Pabucu Wedge Clamp	Pabuç Vidası Clamp Screw	Altlık Shim	Altlık Vidası Shim Screw	Yay Spring	Pul Stamp	Anahtar Allen Key
TTENN 2020 K16	●	●	20	20	125	10								
2525 M16	●	●	25	25	150	12.5								
3232 P16	●	●	32	32	170	16								
2525 M22	●	●	25	25	150	12.5								
3232 P22	●	●	32	32	170	16								
4040 S22	○	○	40	40	250	20								

R: Sağ/Right L: Sol/Left ● Stokta/In Stock ○ Stokta Yok/Non Stock Item

Sipariş Örneği/Ordering Example : 1 ad./pcs. TSSNR 2020 K12

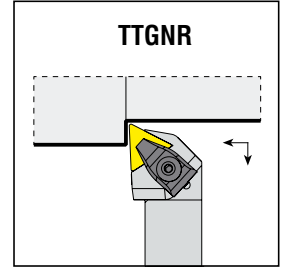
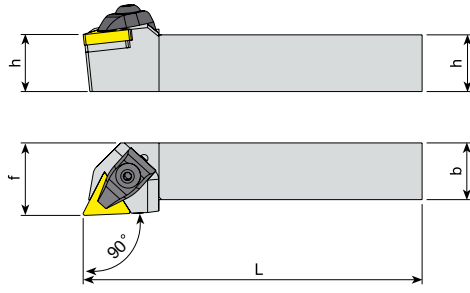

Takım Kodu Ordering Code	Stok Stock		Takım Ölçüleri (mm) Dimension (mm)				Kesici Uç Insert	Yedek Parçaları Spare Parts						
	R	L	h	b	L	f		Baskı Pabucu Wedge Clamp	Pabuç Vidası Clamp Screw	Altık Shim	Altık Vidası Shim Screw	Yay Spring	Pul Stamp	Anahtar Allen Key
	TTGNR/L 2020 K16	●	●	20	20	125		25	TNM. 1604..	ATK-01	AKV-01-M5x22	AATN-2-0002	AAV-03-M5x12	-
2525 M16	●	●	25	25	150	32								
3232 P16	●	○	32	32	170	40								
2525 M22	●	●	25	25	150	32	TNM. 2204..	ATK-02	AKV-02-M6x22	AATN-3-0015	AAV-02-M5x12	AKY-01	ABPL-01	AAL-03-3
3232 P22	●	●	32	32	170	40								
4040 S22	○	○	40	40	250	50								

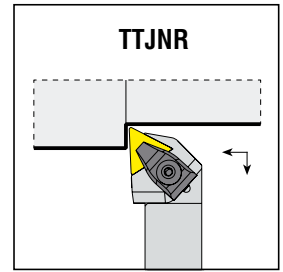
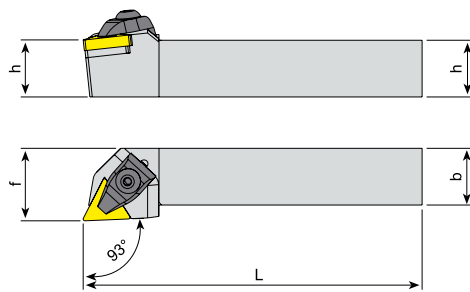

Takım Kodu Ordering Code	Stok Stock		Takım Ölçüleri (mm) Dimension (mm)				Kesici Uç Insert	Yedek Parçaları Spare Parts						
	R	L	h	b	L	f		Baskı Pabucu Wedge Clamp	Pabuç Vidası Clamp Screw	Altık Shim	Altık Vidası Shim Screw	Yay Spring	Pul Stamp	Anahtar Allen Key
	TTJNR/L 2020 K16	●	●	20	20	125		25	TNM. 1604..	ATK-01	AKV-01-M5x22	AATN-2-0002	AAV-03-M5x12	-
2525 M16	●	●	25	25	150	32								
3232 P16	●	●	32	32	170	40								
2525 M22	●	●	25	25	150	32	TNM. 2204..	ATK-02	AKV-02-M6x22	AATN-3-0015	AAV-02-M5x12	AKY-01	ABPL-01	AAL-03-3
3232 P22	●	●	32	32	170	40								
4040 S22	○	○	40	40	250	50								

R: Sağ/Right L: Sol/Left ● Stokta/In Stock ○ Stokta Yok/Non Stock Item

Sipariş Örneği/Ordering Example : 1 ad./pcs. TTGNR 2020 K16

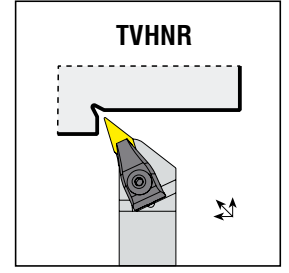
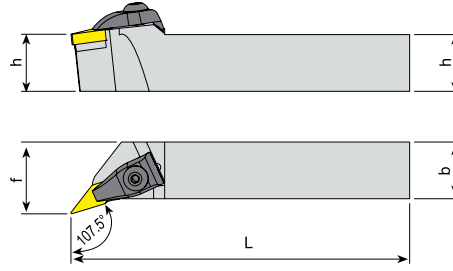

Takım Kodu Ordering Code	Stok Stock		Takım Ölçüleri (mm) Dimension (mm)				Kesici Uç Insert	Yedek Parçaları Spare Parts						
	R	L	h	b	L	f		Baskı Pabucu Wedge Clamp	Pabuç Vidası Clamp Screw	Altılık Shim	Altılık Vidası Shim Screw	Yay Spring	Pul Stamp	Anahtar Allen Key
	●	○												
TVHNR/L 2020 K16	●	●	20	20	125	25	VNM. 1604..	ATK-03	AKV-02-M6x22	AAVN-2-0002	AAV-04-M5x12	AKY-01	ABPL-01	AAL-03-3
2525 M16	●	●	25	25	150	32								
3232 P16	○	○	32	32	170	40								

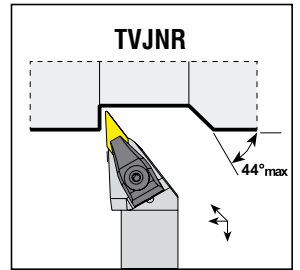
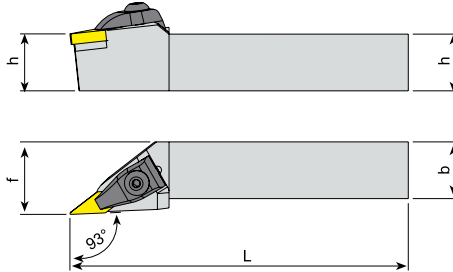

Takım Kodu Ordering Code	Stok Stock		Takım Ölçüleri (mm) Dimension (mm)				Kesici Uç Insert	Yedek Parçaları Spare Parts						
	R	L	h	b	L	f		Baskı Pabucu Wedge Clamp	Pabuç Vidası Clamp Screw	Altılık Shim	Altılık Vidası Shim Screw	Yay Spring	Pul Stamp	Anahtar Allen Key
	●	○												
TVJNR/L 2020 K16	●	●	20	20	125	25	VNM. 1604..	ATK-03	AKV-02-M6x22	AAVN-2-0002	AAV-04-M5x12	AKY-01	ABPL-01	AAL-03-3
2525 M16	●	●	25	25	150	32								
3232 P16	●	●	32	32	170	40								

R: Sağ/Right L: Sol/Left ● Stokta/In Stock ○ Stokta Yok/Non Stock Item

Sipariş Örneği/Ordering Example : 1 ad./pcs. TVHNR 2020 K16

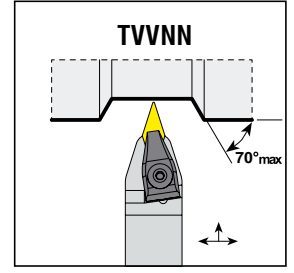
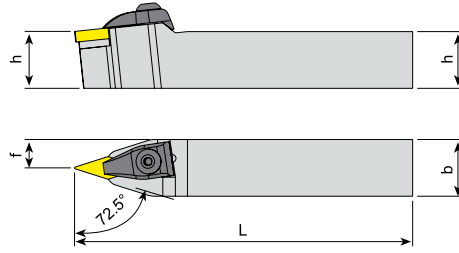

Takım Kodu Ordering Code	Stok Stock	Takım Ölçüleri (mm) Dimension (mm)				Kesici Uç Insert	Yedek Parçaları Spare Parts						
		h	b	L	f		Baskı Pabucu Wedge Clamp	Pabuç Vidası Clamp Screw	Altılık Shim	Altılık Vidası Shim Screw	Yay Spring	Pul Stamp	Anahtar Allen Key
TVVNN 2020 K16	●	20	20	125	10	VNM. 1604..	ATK-03	AKV-02-M6x22	AAVN-2-0002	AAV-04-M5x12	AKY-01	ABPL-01	AAL-03-3
2525 M16	●	25	25	150	12.5								
3232 P16	●	32	32	170	16								

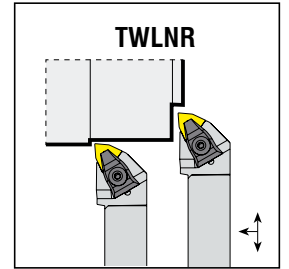
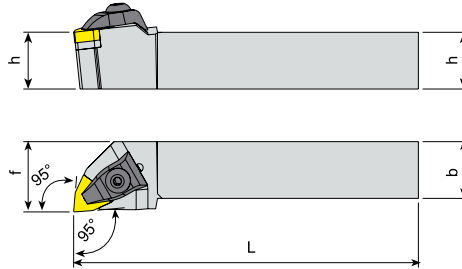

Takım Kodu Ordering Code	Stok Stock		Takım Ölçüleri (mm) Dimension (mm)				Kesici Uç Insert	Yedek Parçaları Spare Parts						
	R	L	h	b	L	f		Baskı Pabucu Wedge Clamp	Pabuç Vidası Clamp Screw	Altılık Shim	Altılık Vidası Shim Screw	Yay Spring	Pul Stamp	Anahtar Allen Key
TWLNR/L 1616 H06	●	●	16	16	100	20	WNM. 0604..	ATK-01	AKV-01-M5x22	AAWN-SW317	AAV-01-M3x10	-	ABPL-01	AAL-03-3
2020 K06	●	●	20	20	125	25								
2525 M06	●	●	25	25	150	32								
2020 K08	●	●	20	20	125	25	WNM. 0804..	ATK-02	AKV-02-M6x22	AAWN-3-0001	AAV-02-M5x12	AKY-01	ABPL-01	AAL-03-3
2525 M08	●	●	25	25	150	32								
3232 P08	●	●	32	32	170	40								
4040 S08	○	○	40	40	250	50								
5050 S08	○	○	50	50	250	63								

R: Sağ/Right L: Sol/Left ● Stokta/In Stock ○ Stokta Yok/Non Stock Item

Sipariş Örneği/Ordering Example : 1 ad./pcs. TVVNN 2020 K16



*konusulan
the spoken kalite...
quality...*

M-SİSTEM

M-SİSTEM DIŞ TORNA KATERLERİ

M-SYSTEM EXTERNAL TURNING TOOLHOLDERS



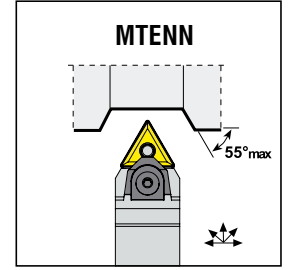
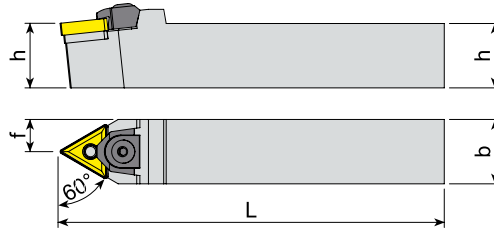

Takım Kodu Ordering Code	Stok Stock		Takım Ölçüleri (mm) Dimension (mm)				Kesici Uç Insert	Yedek Parçaları Spare Parts					
	R	L	h	b	L	f		Baskı Pabucu Wedge Clamp	Pabuç Vidası Clamp Screw	Altık Shim	Pim Pin	Pul Stamp	Anahtar Allen Key
MTENN 2020 K16	●		20	20	125	10	TNM. 1604..	AMK-04	AKV-02-M6x22	AATN-2-0002	APM-01	ABPL-01	AAL-03-3
2525 M16	●		25	25	150	12.5							
3232 P16	●		32	32	170	16	TNM. 2204..			AATN-3-0015	APM-02		
2525 M22	●		25	25	150	12.5							
3232 P22	●		32	32	170	16							
4040 S22	○		40	40	250	20							

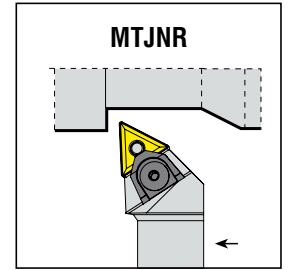
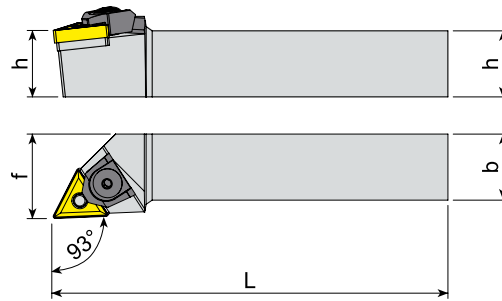

Takım Kodu Ordering Code	Stok Stock		Takım Ölçüleri (mm) Dimension (mm)				Kesici Uç Insert	Yedek Parçaları Spare Parts					
	R	L	h	b	L	f		Baskı Pabucu Wedge Clamp	Pabuç Vidası Clamp Screw	Altık Shim	Pim Pin	Pul Stamp	Anahtar Allen Key
MTJNR/L 2020 K16	●	●	20	20	125	25	TNM. 1604..	AMK-04	AKV-02-M6x22	AATN-2-0002	APM-01	ABPL-01	AAL-03-3
2525 M16	●	●	25	25	150	32							
3232 P16	●	●	32	32	170	40	TNM. 2204..			AATN-3-0015	APM-02		
2525 M22	●	●	25	25	150	32							
3232 P22	●	●	32	32	170	40							
4040 S22	●	●	40	40	250	50							

R: Sağ/Right L: Sol/Left ● Stokta/In Stock ○ Stokta Yok/Non Stock Item

Sipariş Örneği/Ordering Example : 1 ad./pcs. MTENN 2020 K16

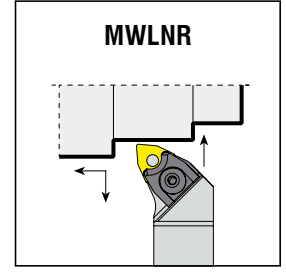
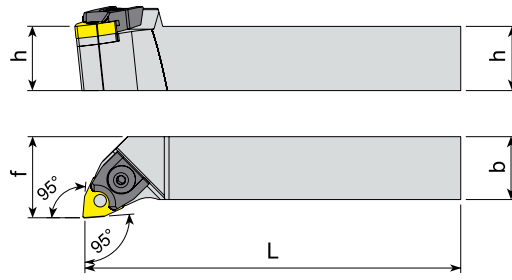

Takım Kodu Ordering Code	Stok Stock		Takım Ölçüleri (mm) Dimension (mm)				Kesici Uç Insert	Yedek Parçaları Spare Parts					
	R	L	h	b	L	f		Baskı Pabucu Wedge Clamp	Pabuç Vidası Clamp Screw	Altlık Shim	Pim Pin	Pul Stamp	Anahtar Allen Key
MWLNLR/L 1616 H06	●	●	16	16	100	20				-		-	AAL-03-3
2020 K06	●	●	20	20	125	25							
2525 M06	●	●	25	25	150	32							
2020 K08	●	●	20	20	125	25				AAWN-3-0001			
2525 M08	●	●	25	25	150	32							
3232 P08	●	●	32	32	170	40							

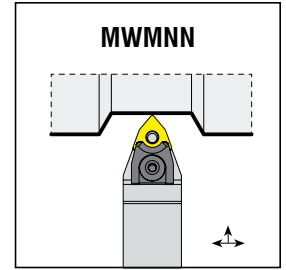
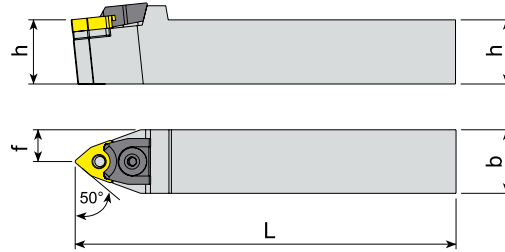

Takım Kodu Ordering Code	Stok Stock		Takım Ölçüleri (mm) Dimension (mm)				Kesici Uç Insert	Yedek Parçaları Spare Parts					
	R	L	h	b	L	f		Baskı Pabucu Wedge Clamp	Pabuç Vidası Clamp Screw	Altlık Shim	Pim Pin	Pul Stamp	Anahtar Allen Key
MWMNN 1616 H06	●	●	16	16	100	8				-		-	AAL-03-3
2020 K06	●	●	20	20	125	10							
2525 M06	●	●	25	25	150	12.5							
2020 K08	●	●	20	20	125	10				AAWN-3-0001			
2525 M08	●	●	25	25	150	12.5							
3232 P08	●	●	32	32	170	16							

R: Sağ/Right L: Sol/Left ● Stokta/In Stock ○ Stokta Yok/Non Stock Item

Sipariş Örneği/Ordering Example : 1 ad./pcs. MWLNLR 1616 H06

P-SİSTEM

P-SİSTEM DIŞ TORNA KATERLERİ

P-SYSTEM EXTERNAL TURNING TOOLHOLDERS

*konusulan
the spoken kalite...
quality...*



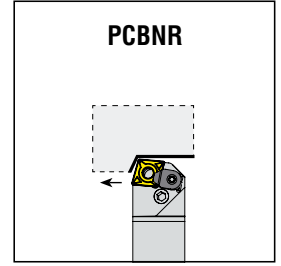
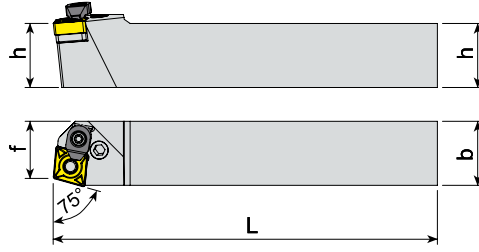

Takım Kodu Ordering Code	Stok Stock		Takım Ölçüleri (mm) Dimension (mm)				Kesici Uç Insert	Yedek Parçaları Spare Parts						
	R	L	h	b	L	f		Levyeye	Levyeye	Altılık	Altılık	Baskı	Baskı	Anahtar
								Lever	Lever Screw	Shim	Shim Spring	Wedge Clamp	Clamp Screw	Allen Key
PCBNR/L 2020 K12C	●	●	20	20	125	17.5								
2525 M12C	●	●	25	25	150	22.5	CNM. 1204..	APL-02	ALV-03-M8x19	AACN-3-0001	AAY-02	ACK-05	1515-M4x11	AAL-03-3
3232 P12C	●	●	32	32	170	27.5		APL-04	ALV-04-M8x22	AACN-3-0002	AAY-03	ACK-09	AAV-05-M6x15	AAL-05-4
2525 M16C	●	●	25	25	150	22		APL-05	ALV-05-M10x27	AACN-3-0003	AAY-04			
3232 P16C	●	●	32	32	170	27	CNM. 1606..	APL-06	ALV-06-M12x36	AACN-3-0008	AAY-05	ACK-04	AKV-16-M6x16	AAL-07-5
3232 P19C	●	●	32	32	170	27		APL-05	ALV-05-M10x27	AACN-3-0003	AAY-04			
4040 S19C	●	●	40	40	250	37	CNM. 1906..	APL-05	ALV-05-M10x27	AACN-3-0003	AAY-04			
4040 S25C	●	●	40	40	250	37		APL-06	ALV-06-M12x36	AACN-3-0008	AAY-05	ACK-04	AKV-16-M6x16	AAL-07-5
5050 S25C	○	○	50	50	250	47		APL-06	ALV-06-M12x36	AACN-3-0008	AAY-05	ACK-04	AKV-16-M6x16	AAL-07-5

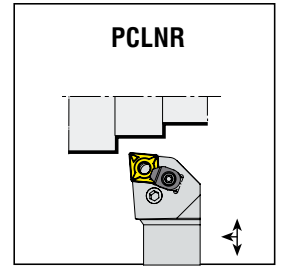
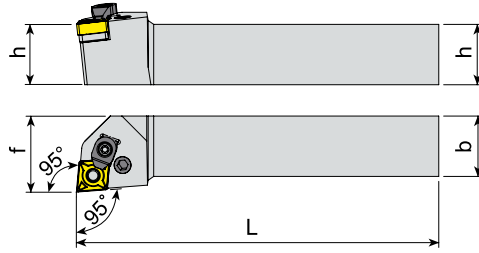

Takım Kodu Ordering Code	Stok Stock		Takım Ölçüleri (mm) Dimension (mm)				Kesici Uç Insert	Yedek Parçaları Spare Parts						
	R	L	h	b	L	f		Levyeye	Levyeye	Altılık	Altılık	Baskı	Baskı	Anahtar
								Lever	Lever Screw	Shim	Shim Spring	Wedge Clamp	Clamp Screw	Allen Key
PCLNR/L 1616 H09	●	●	16	16	100	20								
2020 K09	●	●	20	20	125	25	CNM. 0903..	APL-01	ALV-02-M6x17	AACN-2-0002	AAY-01	-	-	AAL-02-2.5
2525 M09	●	●	25	25	150	32		APL-02	ALV-03-M8x19	AACN-3-0001	AAY-02	ACK-05	1515-M4x11	AAL-03-3
1616 H12C	●	●	16	16	100	20		APL-04	ALV-04-M8x22	AACN-3-0002	AAY-03	ACK-09	AAV-05-M6x15	AAL-05-4
2020 K12C	●	●	20	20	125	25	APL-05	ALV-05-M10x27	AACN-3-0003	AAY-04				
2525 M12C	●	●	25	25	150	32	CNM. 1204..	APL-06	ALV-06-M12x36	AACN-3-0008	AAY-05	ACK-04	AKV-16-M6x16	AAL-07-5
3232 P12C	●	●	32	32	170	40		APL-05	ALV-05-M10x27	AACN-3-0003	AAY-04			
2525 M16C	●	●	25	25	150	32	CNM. 1606..	APL-05	ALV-05-M10x27	AACN-3-0003	AAY-04			
3232 P16C	●	●	32	32	170	40		APL-06	ALV-06-M12x36	AACN-3-0008	AAY-05	ACK-04	AKV-16-M6x16	AAL-07-5
2525 M19C	●	●	25	25	150	32		APL-05	ALV-05-M10x27	AACN-3-0003	AAY-04			
3232 P19C	●	●	32	32	170	40	CNM. 1906..	APL-05	ALV-05-M10x27	AACN-3-0003	AAY-04			
4040 S19C	●	●	40	40	250	50		APL-06	ALV-06-M12x36	AACN-3-0008	AAY-05	ACK-04	AKV-16-M6x16	AAL-07-5
4040 S25C	●	●	40	40	250	50		APL-06	ALV-06-M12x36	AACN-3-0008	AAY-05	ACK-04	AKV-16-M6x16	AAL-07-5
5050 S25C	●	●	50	50	250	60	APL-06	ALV-06-M12x36	AACN-3-0008	AAY-05	ACK-04	AKV-16-M6x16	AAL-07-5	

R: Sağ/Right L: Sol/Left ● Stokta/In Stock ○ Stokta Yok/Non Stock Item

Sipariş Örneği/Ordering Example : 1 ad./pcs. PCBNR 2020 K12C

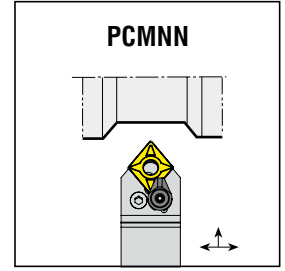
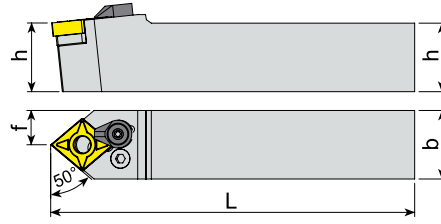

Takım Kodu Ordering Code	Stok Stock		Takım Ölçüleri (mm) Dimension (mm)				Kesici Uç Insert	Yedek Parçaları Spare Parts						
	R	L	h	b	L	f		Levyeye Lever	Levyeye Vidası Lever Screw	Altık Shim	Altık Yayı Shim Spring	Baskı Parçası Wedge Clamp	Baskı Vidası Clamp Screw	Anahtar Allen Key
PCMNN 2020 K12C	●		20	20	125	10	CNM. 1204..	APL-02	ALV-03-M8x19	AACN-3-0001	AAY-02	ACK-05	1515-M4x11	AAL-03-3
2525 M12C	●		25	25	150	12.5								
3232 P12C	○		32	32	170	16								
2525 M16C	○		25	25	150	12.5	CNM. 1606..	APL-04	ALV-04-M8x22	AACN-3-0002	AAY-03	ACK-09	AAV-05-M6x15	AAL-05-4
3232 P16C	○		32	32	170	16								
3232 P19C	●		32	32	170	16								
4040 S19C	○		40	40	250	20	CNM. 1906..	APL-05	ALV-05-M10x27	AACN-3-0003	AAY-04	ACK-04	AKV-16-M6x16	AAL-07-5
5050 S19C	○		50	50	250	25								
4040 S25C	●		40	40	250	20	CNM. 2509..	APL-06	ALV-06-M12x36	AACN-3-0008	AAY-05	ACK-04	AKV-16-M6x16	AAL-07-5

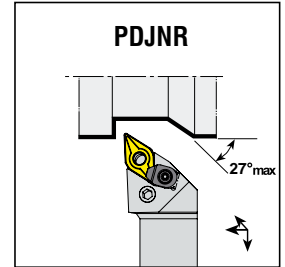
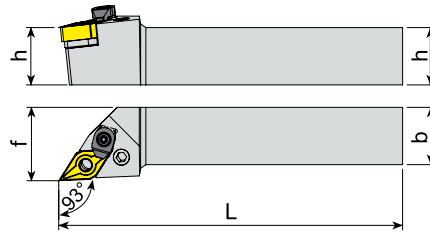

Takım Kodu Ordering Code	Stok Stock		Takım Ölçüleri (mm) Dimension (mm)				Kesici Uç Insert	Yedek Parçaları Spare Parts						
	R	L	h	b	L	f		Levyeye Lever	Levyeye Vidası Lever Screw	Altık Shim	Altık Yayı Shim Spring	Baskı Parçası Wedge Clamp	Baskı Vidası Clamp Screw	Anahtar Allen Key
PDJNR/L 1616 H11	●	●	16	16	100	20	DNM. 1104..	APL-01	ALV-02-M6x17	AADN-SD317	AAY-01	-	-	AAL-02-2.5
2020 K11	●	●	20	20	125	25								
2525 M11	●	●	25	25	150	32								
2020 K15C	●	●	20	20	125	25	DNM. 1506..	APL-03	ALV-03-M8x19	AADN-3-0001	AAY-02	ACK-05	1515-M4x11	AAL-03-3
2525 M15C	●	●	25	25	150	32								
3232 P15C	●	●	32	32	170	40								
4040 S15C	●	●	40	40	250	50								

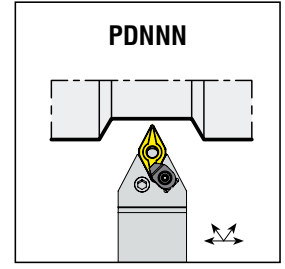
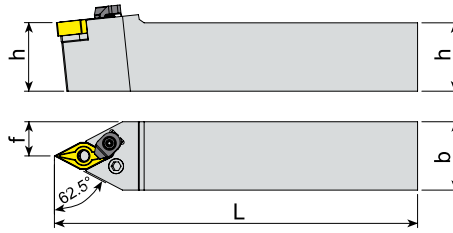

Takım Kodu Ordering Code	Stok Stock		Takım Ölçüleri (mm) Dimension (mm)				Kesici Uç Insert	Yedek Parçaları Spare Parts						
	R	L	h	b	L	f		Levyeye Lever	Levyeye Vidası Lever Screw	Altık Shim	Altık Yayı Shim Spring	Baskı Parçası Wedge Clamp	Baskı Vidası Clamp Screw	Anahtar Allen Key
PDNNN 1616 H11	●		16	16	100	8						-	-	AAL-02-2.5
2020 K11	●		20	20	125	10								
2525 M11	●		25	25	150	12.5								
2020 K15	●		20	20	125	10								AAL-03-3
2525 M15C	●		25	25	150	12.5								
3232 P15C	●		32	32	170	16								

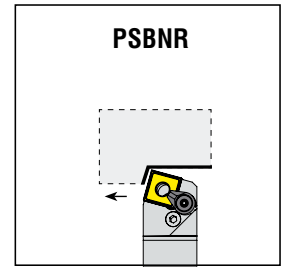
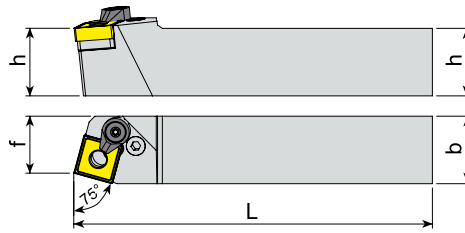

Takım Kodu Ordering Code	Stok Stock		Takım Ölçüleri (mm) Dimension (mm)				Kesici Uç Insert	Yedek Parçaları Spare Parts						
	R	L	h	b	L	f		Levyeye Lever	Levyeye Vidası Lever Screw	Altık Shim	Altık Yayı Shim Spring	Baskı Parçası Wedge Clamp	Baskı Vidası Clamp Screw	Anahtar Allen Key
PSBNR/L 1616 H09	●	●	16	16	100	13						-	-	AAL-02-2.5
2020 K09	○	○	20	20	125	17								
2020 K12	●	●	20	20	125	17								
2525 M12C	●	●	25	25	150	22								AAL-03-3
3232 P12C	●	●	32	32	170	27								
2525 M15C	○	○	25	25	150	22								
3232 P15C	●	●	32	32	170	27								AAL-05-4
3232 P19C	●	●	32	32	170	27								
4040 S19C	●	●	40	40	250	35								
4040 S25C	●	○	40	40	250	35								AAL-05-4
5050 S25C	○	○	50	50	250	43								
5050 S25C	○	○	50	50	250	43								AAL-07-5
5050 S25C	○	○	50	50	250	43								

R: Sağ/Right L: Sol/Left ● Stokta/In Stock ○ Stokta Yok/Non Stock Item

Sipariş Örneği/Ordering Example : 1 ad./pcs. PSBNR 1616 H09

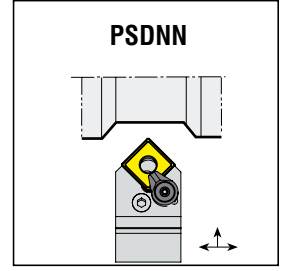
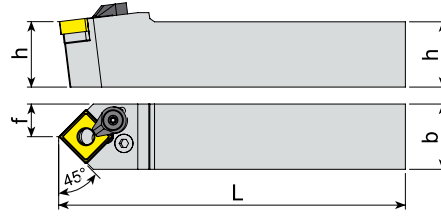

Takım Kodu Ordering Code	Stok Stock	Takım Ölçüleri (mm) Dimension (mm)				Kesici Uç Insert	Yedek Parçaları Spare Parts						
		h	b	L	f		Levye Lever	Levye Vidası Lever Screw	Altlık Shim	Altlık Yayı Shim Spring	Baskı Parçası Wedge Clamp	Baskı Vidası Clamp Screw	Anahtar Allen Key
PSDNN 1616 H09	●	16	16	100	8	SNM. 0903..	APL-01	ALV-02-M6x17	AASN-2-0002	AAY-01	-	-	AAL-02-2.5
2020 K12C	●	20	20	125	10	SNM. 1204..	APL-02	ALV-03-M8x19	AASN-3-0004	AAY-02	ACK-05	1515-M4x11	AAL-03-3
2525 M12C	●	25	25	150	12.5								
3232 P12C	●	32	32	170	16								
2020 K15C	○	20	20	125	10	SNM. 1506..	APL-04	ALV-04-M8x22	AASN-3-0023	AAY-03	ACK-09	AAV-05-M6x15	AAL-05-4
2525 M15C	●	25	25	150	12.5								
3232 P19C	●	32	32	170	16								
4040 S19C	○	40	40	250	20	SNM. 1906..	APL-05	ALV-05-M10x27	AASN-3-0005	AAY-04	ACK-09	AAV-05-M6x15	AAL-05-4
5050 S19C	○	50	50	250	25								
4040 S25C	●	40	40	250	20	SNM. 2509..	APL-06	ALV-06-M12x36	AASN-3-0020	AAY-05	ACK-04	AKV-16-M6x16	AAL-07-5
5050 S25C	○	50	50	250	25								

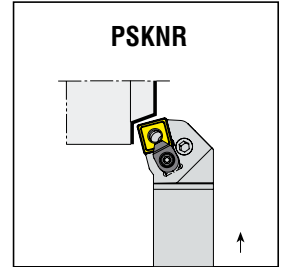
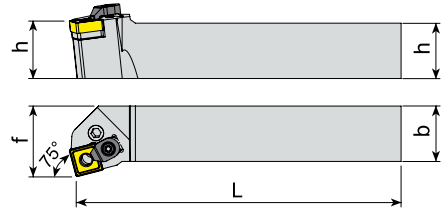

Takım Kodu Ordering Code	Stok Stock		Takım Ölçüleri (mm) Dimension (mm)				Kesici Uç Insert	Yedek Parçaları Spare Parts						
	R	L	h	b	L	f		Levye Lever	Levye Vidası Lever Screw	Altlık Shim	Altlık Yayı Shim Spring	Baskı Parçası Wedge Clamp	Baskı Vidası Clamp Screw	Anahtar Allen Key
PSKNR/L 2020 K09	●	○	20	20	125	25	SNM. 0903..	APL-01	ALV-02-M6x17	AASN-2-0002	AAY-01	-	-	AAL-02-2.5
2020 K12C	●	●	20	20	125	25	SNM. 1204..	APL-02	ALV-03-M8x19	AASN-3-0004	AAY-02	ACK-05	1515-M4x11	AAL-03-3
2525 M12C	●	●	25	25	150	32								
3232 P12C	●	●	32	32	170	40								
2525 M15C	●	●	25	25	150	32	SNM. 1506..	APL-04	ALV-04-M8x22	AASN-3-0023	AAY-03	ACK-09	AAV-05-M6x15	AAL-05-4
3232 P15C	●	○	32	32	170	40								
3232 P19C	●	○	32	32	170	40								
4040 S19C	●	○	40	40	250	50	SNM. 1906..	APL-05	ALV-05-M10x27	AASN-3-0005	AAY-04	ACK-09	AAV-05-M6x15	AAL-05-4
4040 S25C	●	○	40	40	250	50								
5050 S25C	●	○	50	50	250	60	SNM. 2509..	APL-06	ALV-06-M12x36	AASN-3-0020	AAY-05	ACK-04	AKV-16-M6x16	AAL-07-5

R: Sağ/Right L: Sol/Left ● Stokta/In Stock ○ Stokta Yok/Non Stock Item

Sipariş Örneği/Ordering Example : 1 ad./pcs. PSDNN 1616 H09

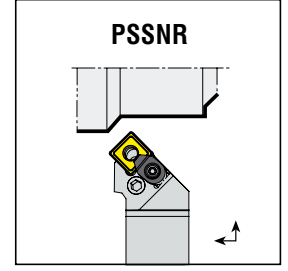
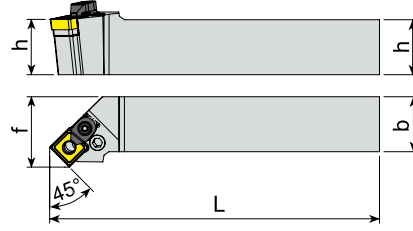

Takım Kodu Ordering Code	Stok Stock		Takım Ölçüleri (mm) Dimension (mm)				Kesici Uç Insert	Yedek Parçaları Spare Parts						
	R	L	h	b	L	f		Levye Lever	Levye Vidası Lever Screw	Altlık Shim	Altlık Yayı Shim Spring	Baskı Parçası Wedge Clamp	Baskı Vidası Clamp Screw	Anahtar Allen Key
PSSNR/L 1616 H09	●	○	16	16	100	20	SNM. 0903..	APL-01	ALV-02-M6x17	AASN-2-0002	AAV-01	-	-	AAL-02-2.5
2020 K09	●	○	20	20	125	25								
2020 K12C	●	●	20	20	125	25	SNM. 1204..	APL-02	ALV-03-M8x19	AASN-3-0004	AAV-02	ACK-05	1515-M4x11	AAL-03-3
2525 M12C	●	●	25	25	150	32								
3232 P12C	●	●	32	32	170	40	SNM. 1506..	APL-04	ALV-04-M8x22	AASN-3-0023	AAV-03	ACK-09	AAV-05-M6x15	AAL-05-4
3232 P15C	○	○	32	32	170	40								
3232 P19C	●	●	32	32	170	40	SNM. 1906..	APL-05	ALV-05-M10x27	AASN-3-0005	AAV-04			
4040 S19C	●	●	40	40	250	50	SNM. 2509..	APL-06	ALV-06-M12x36	AASN-3-0020	AAV-05	ACK-04	AKV-16-M6x16	AAL-07-5

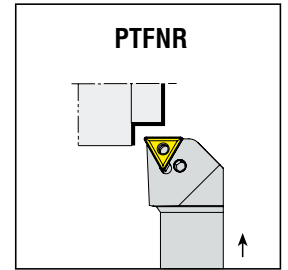
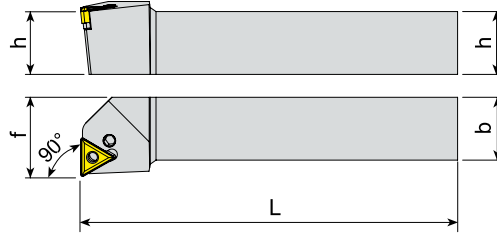

Takım Kodu Ordering Code	Stok Stock		Takım Ölçüleri (mm) Dimension (mm)				Kesici Uç Insert	Yedek Parçaları Spare Parts						
	R	L	h	b	L	f		Levye Lever	Levye Vidası Lever Screw	Altlık Shim	Altlık Yayı Shim Spring	Baskı Parçası Wedge Clamp	Baskı Vidası Clamp Screw	Anahtar Allen Key
PTFNR/L 1616 H16	●	●	16	16	100	20	TNM. 1604..	APL-01	ALV-02-M6x17	AATN-3-0025	AAV-01	-	-	AAL-02-2.5
2020 K16	●	●	20	20	125	25								
2525 M16	●	●	25	25	150	32								
3232 P16	●	●	32	32	170	40								
2525 M22C	●	●	25	25	150	32	TNM. 2204..	APL-02	ALV-03-M8x19	AATN-3-0015	AAV-02	ACK-05	1515-M4x11	AAL-03-3
3232 P22C	●	●	32	32	170	40								
4040 S27	○	○	40	40	250	50	TNM. 2706.	07042709	07042710	07042701	07042711	-	-	AAL-05-4

R: Sağ/Right L: Sol/Left ● Stokta/In Stock ○ Stokta Yok/Non Stock Item

Sipariş Örneği/Ordering Example : 1 ad./pcs. PSSNR 1616 H09

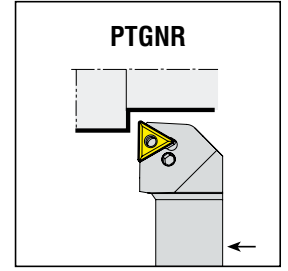
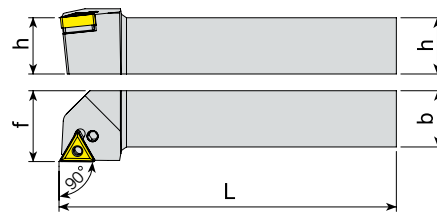

Takım Kodu Ordering Code	Stok Stock		Takım Ölçüleri (mm) Dimension (mm)				Kesici Uç Insert	Yedek Parçaları Spare Parts								
	R	L	h	b	L	f		Levyeye Lever	Levyeye Vidası Lever Screw	Altılık Shim	Altılık Yayı Shim Spring	Baskı Parçası Wedge Clamp	Baskı Vidası Clamp Screw	Anahtar Allen Key		
PTGNR/L 1010 E11	○	○	10	10	70	12			07041109	07041110	-	-	-	-	-	-
1212 F11	○	○	12	12	80	16										
1616 H11	○	○	16	16	100	20										
1616 H16	●	●	16	16	100	20	TNM. 1604..	APL-01	ALV-02-M6x17	AATN-3-0025	AAY-01	-	-	-	-	AAL-02-2.5
2020 K16	●	●	20	20	125	25										
2525 M16	●	●	25	25	150	32										
3232 P16	○	○	32	32	170	40	TNM. 2204..	APL-02	ALV-03-M8x19	AATN-3-0015	AAY-02	ACK-05	1515-M4x11	-	-	AAL-03-3
2525 M22C	●	●	25	25	150	32										
3232 P22C	○	○	32	32	170	40										
4040 S27	○	○	40	40	250	50	TNM. 2706..	07042709	07042710	07042701	07042711	-	-	-	-	AAL-05-4

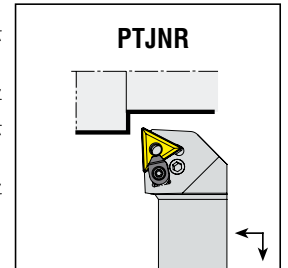
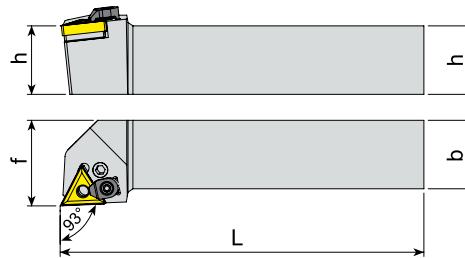

Takım Kodu Ordering Code	Stok Stock		Takım Ölçüleri (mm) Dimension (mm)				Kesici Uç Insert	Yedek Parçaları Spare Parts									
	R	L	h	b	L	f		Levyeye Lever	Levyeye Vidası Lever Screw	Altılık Shim	Altılık Yayı Shim Spring	Baskı Parçası Wedge Clamp	Baskı Vidası Clamp Screw	Anahtar Allen Key			
PTJNR/L 1010 E11	○	○	10	10	70	12			07041109	07041110	-	-	-	-	-	-	-
1212 F11	○	○	12	12	80	16											
1616 H11	○	○	16	16	100	20											
1616 H16	●	●	16	16	100	20	TNM. 1604..	APL-01	ALV-02-M6x17	AATN-3-0025	AAY-01	-	-	-	-	AAL-02-2.5	
2020 K16	●	●	20	20	125	25											
2525 M16	●	●	25	25	150	32											
3232 P16	●	●	32	32	170	40	TNM. 2204..	APL-02	ALV-03-M8x19	AATN-3-0015	AAY-02	ACK-5	1515-M4x11	-	-	AAL-03-3	
2525 M22C	●	●	25	25	150	32											
3232 P22C	●	●	32	32	170	40											
4040 S27	○	○	40	40	250	50	TNM. 2706..	07042709	07042710	07042701	07042711	-	-	-	-	AAL-05-4	

R: Sağ/Right L: Sol/Left ● Stokta/In Stock ○ Stokta Yok/Non Stock Item

Sipariş Örneği/Ordering Example : 1 ad./pcs. PTGNR 1010 E11

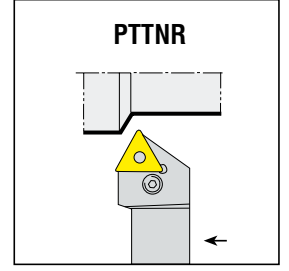
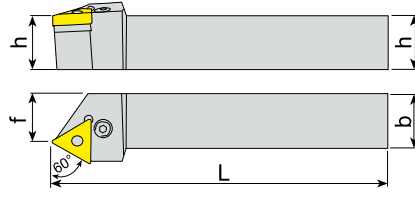

Takım Kodu Ordering Code	Stok Stock		Takım Ölçüleri (mm) Dimension (mm)				Kesici Uç Insert	Yedek Parçaları Spare Parts						
	R	L	h	b	L	f		Levyeye Lever	Levyeye Vidası Lever Screw	Altılık Shim	Altılık Yayı Shim Spring	Baskı Parçası Wedge Clamp	Baskı Vidası Clamp Screw	Anahtar Allen Key
PTTNR/L 1616 H16	●	●	16	16	100	13	TNM. 1604..					-	-	AAL-02-2.5
2020 K16	●	●	20	20	125	17								
2525 M16	●	●	25	25	150	21.5								
3232 P16	●	●	32	32	170	31								
2525 M22C	●	●	25	25	150	20.5	TNM. 2204..					ACK-05	1515-M4x11	AAL-03-3
3232 P22C	●	●	32	32	170	29								

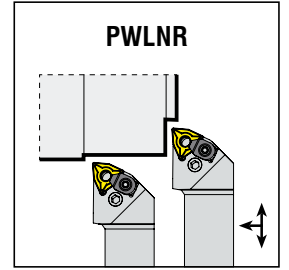
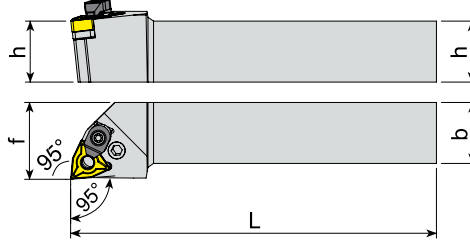

Takım Kodu Ordering Code	Stok Stock		Takım Ölçüleri (mm) Dimension (mm)				Kesici Uç Insert	Yedek Parçaları Spare Parts						
	R	L	h	b	L	f		Levyeye Lever	Levyeye Vidası Lever Screw	Altılık Shim	Altılık Yayı Shim Spring	Baskı Parçası Wedge Clamp	Baskı Vidası Clamp Screw	Anahtar Allen Key
PWLNR/L 1616 H06	●	●	16	16	100	20	WNM. 0604..					-	-	AAL-02-2.5
2020 K06	●	●	20	20	125	25								
2525 M06	●	●	25	25	150	32								
3232 P06	○	○	32	32	170	40								
1616 H08	●	●	16	16	100	20	WNM. 0804..					ACK-05	1515-M4x11	AAL-03-3
2020 K08C	●	●	20	20	125	25								
2525 M08C	●	●	25	25	150	32								
3232 P08C	●	●	32	32	170	40								

R: Sağ/Right L: Sol/Left ● Stokta/In Stock ○ Stokta Yok/Non Stock Item

Sipariş Örneği/Ordering Example : 1 ad./pcs. PTTNR 1616 H16

konusulan
the spoken kalite...
quality...





*konusulan
the spoken kalite...
quality...*

C-SİSTEM

C-SİSTEM DIŞ TORNA KATERLERİ

C-SYSTEM EXTERNAL TURNING TOOLHOLDERS



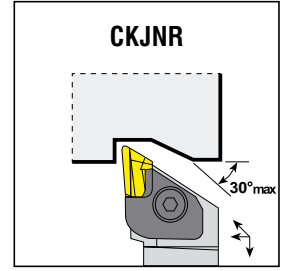
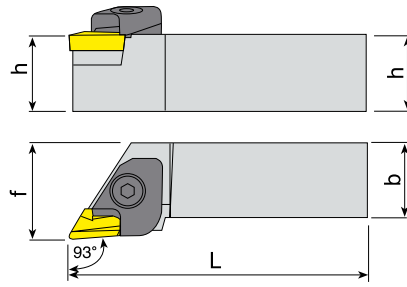

Takım Kodu Ordering Code	Stok Stock		Takım Ölçüleri (mm) Dimension (mm)				Kesici Uç Insert	Yedek Parçaları Spare Parts													
	R	L	h	b	L	f		Baskı Pabucu Wedge Clamp	Pabuç Vidası Clamp Screw	Altlık Shim	Altlık Vidası Shim Screw	Yay Spring	Pul Stamp	Anahtar Allen Key							
	●	○																			
CKJNR/L 2020 K16	●	●	20	20	125	25	KNUX 1604..														
2525 M16	●	●	25	25	150	32									ACK-01-R	AKV-06-M6x20	AKS-16-R	AAV-01-M3x10	AKY-02	ABPL-01	AAL-05-4
3232 P16	●	●	32	32	170	40									ACK-02-L		AKS-16-L				
4040 S16	●	●	40	40	250	50															

C-SİSTEM SERAMİK UÇLAR İÇİN DIŞ TORNA KATERLERİ
C-SYSTEM EXTERNAL TURNING TOOLHOLDERS FOR CERAMIC INSERTS

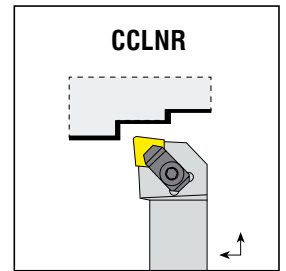
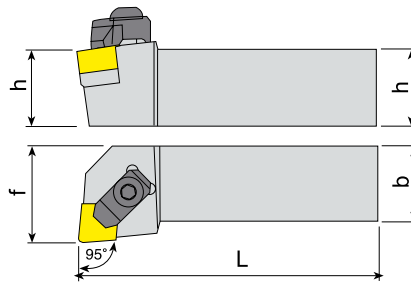

Takım Kodu Ordering Code	Stok Stock		Takım Ölçüleri (mm) Dimension (mm)				Kesici Uç Insert	Yedek Parçaları Spare Parts					
	R	L	h	b	L	f		Baskı Pabucu Wedge Clamp	Pabuç Vidası Clamp Screw	Altlık Shim	Altlık Vidası Shim Screw	Sekman Ring	Anahtar Allen Key
	●	○											
CCLNR/L 2525 M1207C	●	●	25	25	150	32	CN.N 1207..						
3232 P1207C	●	●	32	32	170	40							
2525 M1607C	●	○	25	25	150	32	CN.N 1607..	ACK-13	AKV-11-M8x29	AACN-3-0002	AAV-05-M6x15	ACS-01	AAL-05-4

R: Sağ/Right L: Sol/Left ● Stokta/In Stock ○ Stokta Yok/Non Stock Item

Sipariş Örneği/Ordering Example : 1 ad./pcs. CCLNR 2525 M1207C

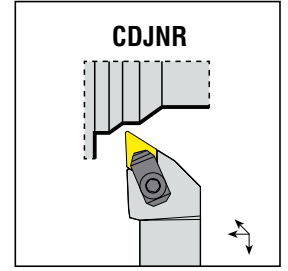
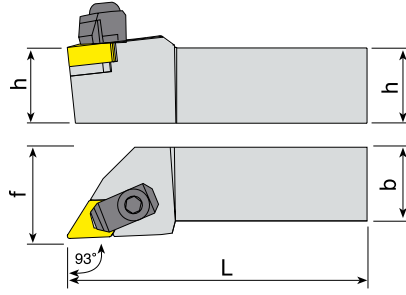

Takım Kodu Ordering Code	Stok Stock		Takım Ölçüleri (mm) Dimension (mm)				Kesici Uç Insert	Yedek Parçaları Spare Parts					
	R	L	h	b	L	f		Baskı Pabucu Wedge Clamp	Pabuç Vidası Clamp Screw	Altık Shim	Altık Vidası Shim Screw	Sekman Ring	Anahtar Allen Key
CDJNR/L 2525 M1107C	●	●	25	25	150	32	DN.N 1107..	ACK-22	AKV-11-M8x29	AADN-2-0001	AAV-04-M5x12	ACS-01	AAL-05-4
2525 M1507C	●	●	25	25	150	32	DN.N 1507..	ACK-13	AKV-11-M8x29	AADN-3-0001	AAV-02-M5x12	ACS-01	AAL-05-4
3232 P1507C	●	●	32	32	170	40							



62.5°

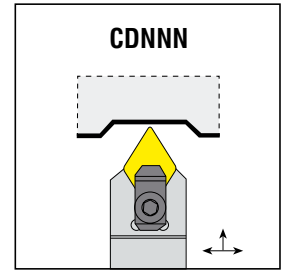
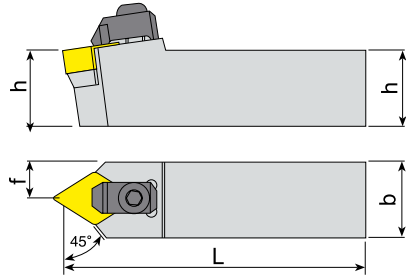

Takım Kodu Ordering Code	Stok Stock		Takım Ölçüleri (mm) Dimension (mm)				Kesici Uç Insert	Yedek Parçaları Spare Parts					
	R	L	h	b	L	f		Baskı Pabucu Wedge Clamp	Pabuç Vidası Clamp Screw	Altık Shim	Altık Vidası Shim Screw	Sekman Ring	Anahtar Allen Key
CDNNN 2525 M1107C	●		25	25	150	12.5	DN.N 1107..	ACK-22	AKV-11-M8x29	AADN-2-0001	AAV-04-M5x12	ACS-01	AAL-05-4

R: Sağ/Right L: Sol/Left ● Stokta/In Stock ○ Stokta Yok/Non Stock Item

Sipariş Örneği/Ordering Example : 1 ad./pcs. CDJNR 2525 M1507C

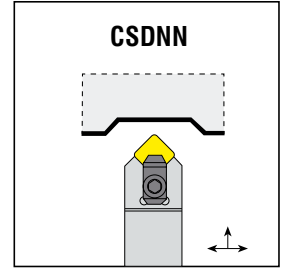
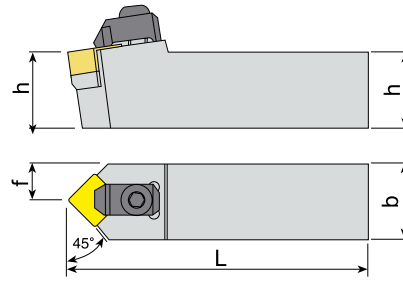

Takım Kodu Ordering Code	Stok Stock		Takım Ölçüleri (mm) Dimension (mm)				Kesici Uç Insert	Yedek Parçaları Spare Parts					
	R	L	h	b	L	f		Baskı Pabucu Wedge Clamp	Pabuç Vidası Clamp Screw	Altlık Shim	Altlık Vidası Shim Screw	Sekman Ring	Anahtar Allen Key
CSDNN 2525 M1207C 3232 P1207C	●		25	25	150	12.5	SN.N 1207..						
		●	32	32	170	16							

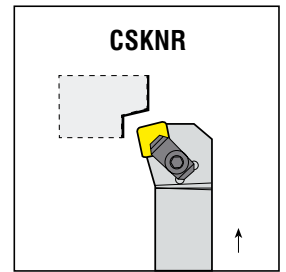
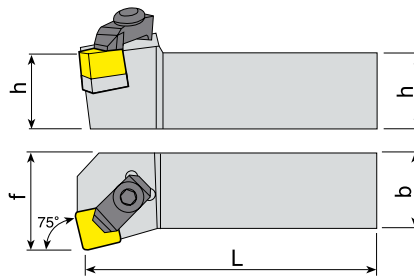

Takım Kodu Ordering Code	Stok Stock		Takım Ölçüleri (mm) Dimension (mm)				Kesici Uç Insert	Yedek Parçaları Spare Parts					
	R	L	h	b	L	f		Baskı Pabucu Wedge Clamp	Pabuç Vidası Clamp Screw	Altlık Shim	Altlık Vidası Shim Screw	Sekman Ring	Anahtar Allen Key
CSKNR/L 2525 M1207C 3232 P1207C	●	●	25	25	150	32	SN.N 1207..						
	●	●	32	32	170	40							

R: Sağ/Right L: Sol/Left ● Stokta/In Stock ○ Stokta Yok/Non Stock Item

Sipariş Örneği/Ordering Example : 1 ad./pcs. CSDNN 2525 M1207C

> C-SİSTEM SERAMİK UÇLAR İÇİN DİŞ TORNA KATERLERİ
C-SYSTEM EXTERNAL TURNING TOOLHOLDERS FOR CERAMIC INSERTS

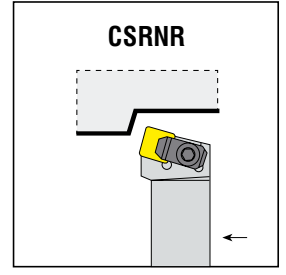
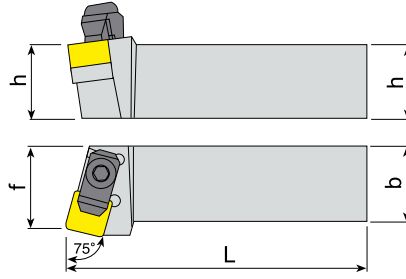

Takım Kodu Ordering Code	Stok Stock		Takım Ölçüleri (mm) Dimension (mm)				Kesici Uç Insert	Yedek Parçaları Spare Parts					
	R	L	h	b	L	f		Baskı Pabucu Wedge Clamp	Pabuç Vidası Clamp Screw	Altılık Shim	Altılık Vidası Shim Screw	Sekman Ring	Anahtar Allen Key
	●	○											
CSRNR/L 2525 M1207C	●	●	25	25	150	32	SN.N 1207..	ACK-13	AKV-11-M8x29	AASN-3-0004	AAV-02-M5x12	ACS-01	AAL-05-4
3232 P1207C	●	○	32	32	170	40							

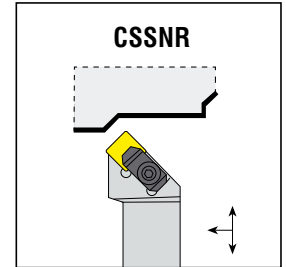
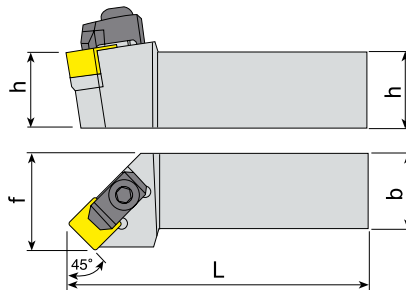

Takım Kodu Ordering Code	Stok Stock		Takım Ölçüleri (mm) Dimension (mm)				Kesici Uç Insert	Yedek Parçaları Spare Parts					
	R	L	h	b	L	f		Baskı Pabucu Wedge Clamp	Pabuç Vidası Clamp Screw	Altılık Shim	Altılık Vidası Shim Screw	Sekman Ring	Anahtar Allen Key
	●	○											
CSSNR/L 2525 M1207C	●	●	25	25	150	32	SN.N 1207..	ACK-13	AKV-11-M8x29	AASN-3-0004	AAV-02-M5x12	ACS-01	AAL-05-4
3232 P1207C	●	●	32	32	170	40							

R: Sağ/Right L: Sol/Left ● Stokta/In Stock ○ Stokta Yok/Non Stock Item

Sipariş Örneği/Ordering Example : 1 ad./pcs. CSRNR 2525 M1207C

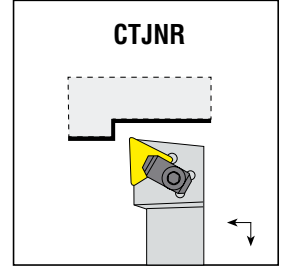
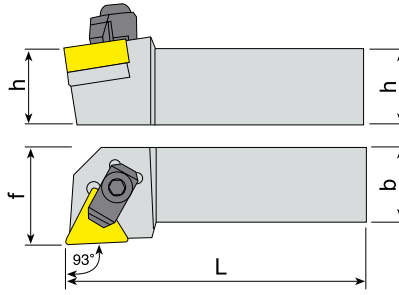

Takım Kodu Ordering Code	Stok Stock		Takım Ölçüleri (mm) Dimension (mm)				Kesici Uç Insert	Yedek Parçaları Spare Parts					
	R	L	h	b	L	f		Baskı Pabucu Wedge Clamp	Pabuç Vidası Clamp Screw	Altlık Shim	Altlık Vidası Shim Screw	Sekman Ring	Anahtar Allen Key
CTJNR/L 2525 M1607C	●	●	25	25	150	32	TN.N 1607..						
3232 P1607C	○	○	32	32	170	40							

R: Sağ/Right L: Sol/Left ● Stokta/In Stock ○ Stokta Yok/Non Stock Item

Sipariş Örneği/Ordering Example : 1 ad./pcs. CTJNR 2525 M1607C





*konusulan
the spoken kalite...
quality...*

S-SİSTEM

S-SİSTEM DIŞ TORNA KATERLERİ

S-SYSTEM EXTERNAL TURNING TOOLHOLDERS



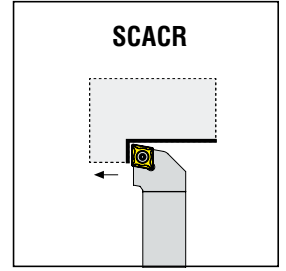
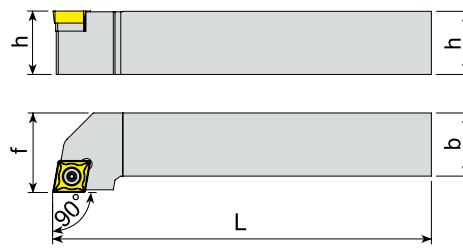

Takım Kodu Ordering Code	Stok Stock		Takım Ölçüleri (mm) Dimension (mm)				Kesici Uç Insert	Yedek Parçaları Spare Parts			
	R	L	h	b	L	f		Sıkma Vidası Screw	Aitlik Shim	Aitlik Vidası Shim Screw	Tork Anahtar Torx Key
SCACR/L 0808 E06	●	●	08	08	70	10	CCM. 0602..				80-T08
1010 E06	●	●	10	10	70	12					
1212 F09	●	●	12	12	80	16					
1616 H09	●	●	16	16	100	20	CCM. 09T3..				80-T15
2020 K09	●	●	20	20	125	25					
2020 K12	●	●	20	20	125	25	CCM. 1204..				80-T20
2525 M12	●	●	25	25	150	32					

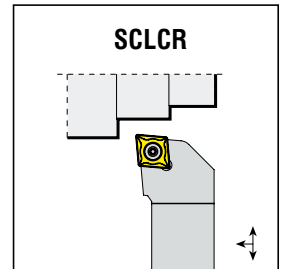
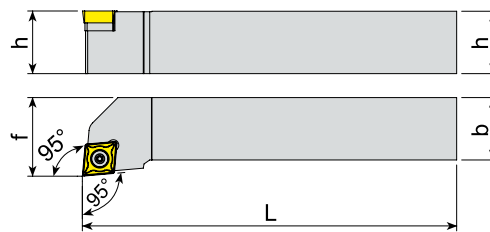

Takım Kodu Ordering Code	Stok Stock		Takım Ölçüleri (mm) Dimension (mm)				Kesici Uç Insert	Yedek Parçaları Spare Parts			
	R	L	h	b	L	f		Sıkma Vidası Screw	Aitlik Shim	Aitlik Vidası Shim Screw	Tork Anahtar Torx Key
SCLCR/L 0808 E06	●	●	08	08	70	10	CCM. 0602..				80-T08
1010 E06	●	●	10	10	70	12					
1212 F09	●	●	12	12	80	16					
1616 H09	●	●	16	16	100	20	CCM. 09T3..				80-T15
2020 K09	●	●	20	20	125	25					
2525 M09	●	○	25	25	150	32	CCM. 1204..				80-T20
2020 K12	●	●	20	20	125	25					
2525 M12	●	●	25	25	150	32					

R: Sağ/Right L: Sol/Left ● Stokta/In Stock ○ Stokta Yok/Non Stock Item

Sipariş Örneği/Ordering Example : 1 ad./pcs. SCACR 0808 E06

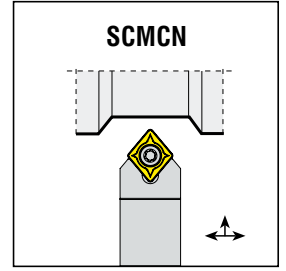
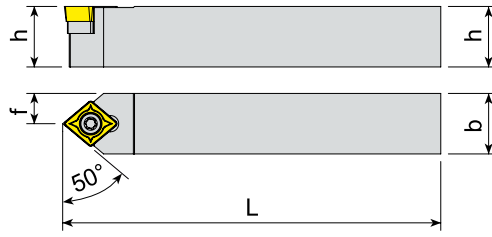

Takım Kodu Ordering Code	Stok Stock	Takım Ölçüleri (mm) Dimension (mm)				Kesici Uç Insert	Yedek Parçaları Spare Parts			
		h	b	L	f		Sıkma Vidası Screw	Aitlik Shim	Aitlik Vidası Shim Screw	Tork Anahtar Torx Key
SCMCN 0808 E06	●	08	08	70	04	CCM. 0602..	4008-M2.5x6	-	-	80-T08
1010 E06	●	10	10	70	05					
1212 F09	●	12	12	80	06	CCM. 09T3..	4015-M3.5x11	-	-	80-T15
1616 H09	●	16	16	100	08					
2020 K12	●	20	20	125	10	CCM. 1204..	1020-M4.5x16	AACN-2-0001	AAV-06-M3.5x11	80-T20
2525 M12	○	25	25	150	12.5					

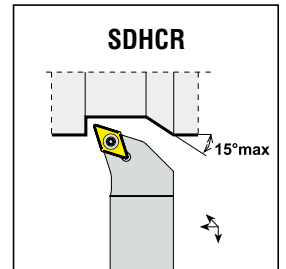
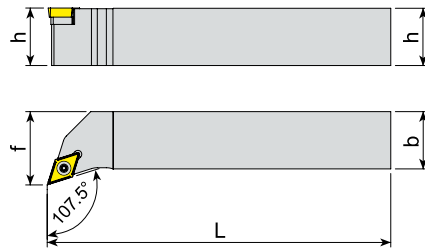

Takım Kodu Ordering Code	Stok Stock		Takım Ölçüleri (mm) Dimension (mm)				Kesici Uç Insert	Yedek Parçaları Spare Parts			
	R	L	h	b	L	f		Sıkma Vidası Screw	Aitlik Shim	Aitlik Vidası Shim Screw	Tork Anahtar Torx Key
SDHCR/L 0808 E07	●	●	08	08	70	10	DCM. 0702..	4008-M2.5x6	-	-	80-T08
1010 E07	●	●	10	10	70	12					
1212 F07	●	●	12	12	80	16					
1616 H07	●	●	16	16	100	20					
1616 H11	●	●	16	16	100	20	DCM. 11T3..	4015-M3.5x14	AADN-2-0001	AAV-06-M3.5x11	80-T15
2020 K11	●	●	20	20	125	25					
2525 M11	●	●	25	25	150	32					
3232 P11	●	●	32	32	170	40					

R: Sağ/Right L: Sol/Left ● Stokta/In Stock ○ Stokta Yok/Non Stock Item

Sipariş Örneği/Ordering Example : 1 ad./pcs. SCMCN 0808 E06

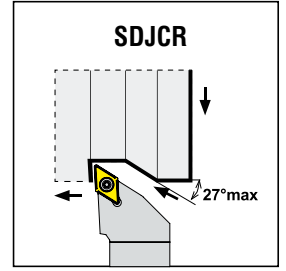
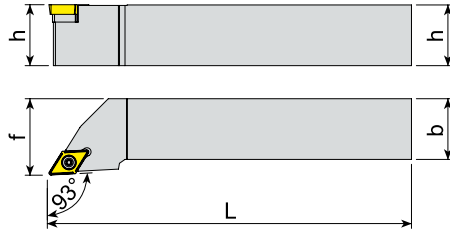

Takım Kodu Ordering Code	Stok Stock		Takım Ölçüleri (mm) Dimension (mm)				Kesici Uç Insert	Yedek Parçaları Spare Parts			
	R	L	h	b	L	f		Sıkma Vidası Screw	Aitlik Shim	Aitlik Vidası Shim Screw	Tork Anahtar Torx Key
SDJCR/L 0808 E07	●	●	08	08	70	10					
1010 E07	●	●	10	10	70	12					
1212 F07	●	●	12	12	80	16					
1616 H07	●	●	16	16	100	20					
1616 H11	●	●	16	16	100	20					
2020 K11	●	●	20	20	125	25					
2525 M11	●	●	25	25	150	32					
3232 P11	●	●	32	32	170	40					

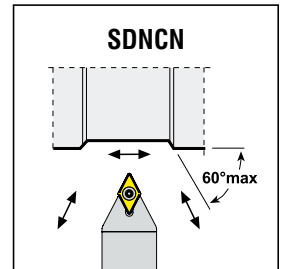
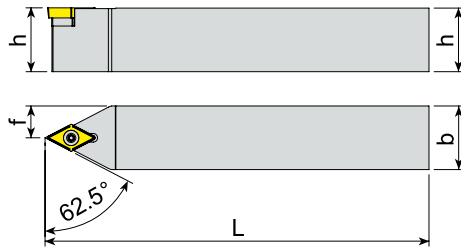

Takım Kodu Ordering Code	Stok Stock		Takım Ölçüleri (mm) Dimension (mm)				Kesici Uç Insert	Yedek Parçaları Spare Parts			
	R	L	h	b	L	f		Sıkma Vidası Screw	Aitlik Shim	Aitlik Vidası Shim Screw	Tork Anahtar Torx Key
SDNCN 0808 E07	●	●	08	08	70	4					
1010 E07	●	●	10	10	70	5					
1212 F07	●	●	12	12	80	6					
1616 H07	●	●	16	16	100	8					
1616 H11	●	●	16	16	100	8					
2020 K11	●	●	20	20	125	10					
2525 M11	●	●	25	25	150	12.5					
3232 P11	●	●	32	32	170	16					

R: Sağ/Right L: Sol/Left ● Stokta/In Stock ○ Stokta Yok/Non Stock Item

Sipariş Örneği/Ordering Example : 1 ad./pcs. SDJCR 0808 E07

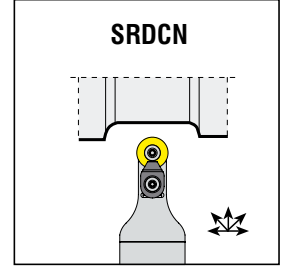
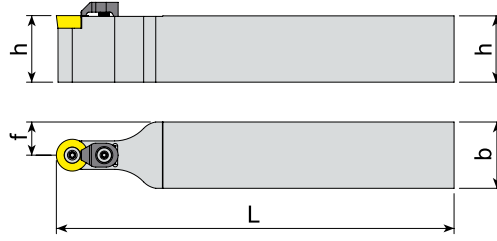

Takım Kodu Ordering Code	Stok Stock	Takım Ölçüleri (mm) Dimension (mm)				Kesici Uç Insert	Yedek Parçaları Spare Parts					
		h	b	L	f		Sıkma Vidası Screw	Altılık Shim	Altılık Vidası Shim Screw	Baskı Parçası Wedge Clamp	Baskı Vidası Clamp Screw	Tork Anahtar Torx Key
SRDCN 1616 H06	●	16	16	100	8	RC.T 0602..	4008-M2.5x6	-	-	-	-	80-T08
2020 K06	●	20	20	125	10							
2525 M06	●	25	25	150	12.5							
1616 H08C	●	16	16	100	8	RC.T 0803..	1008-M3x8	-	-	-	-	80-T08
2020 K08C	●	20	20	125	10							
2525 M08C	●	25	25	150	12.5							
1616 H10C	●	16	16	100	8	RC.T 10T3..	4015-M3.5x11	-	-	ACK-15	1015-M3.5x11	80-T15
2020 K10C	●	20	20	125	10							
2525 M10C	●	25	25	150	12.5							
3232 P10C	●	32	32	170	16							
2020 K12C	●	20	20	125	10	RC.T 1204..	4015-M3.5x11	-	-	ACK-05	1515-M4x11	80-T15
2525 M12C	●	25	25	150	12.5							
3232 P12C	●	32	32	170	16							
2525 M16C	●	25	25	150	12.5	RC.T 1605..	1020-M5x11	-	-	ACK-05	1515-M4x11	80-T20
3232 P16C	●	32	32	170	16							
2525 M20C	●	25	25	150	12.5	RC.T 2006..	1420-M6x16	-	-	ACK-09	AAV-05-M6x15	80-T20
3232 P20C	●	32	32	170	16							
3232 P25C	●	32	32	170	16	RC.T 2507..	1520-M6x16	-	-	ACK-09	AAV-05-M6x15	80-T20
3232 P32C	●	32	32	170	16	RC.T 3209..	1904-M8x1x20	-	-	ACK-09	AAV-05-M6x15	AAL-05-4

R: Sağ/Right L: Sol/Left ● Stokta/In Stock ○ Stokta Yok/Non Stock Item

Sipariş Örneği/Ordering Example : 1 ad./pcs. SRDCN 1616 H06



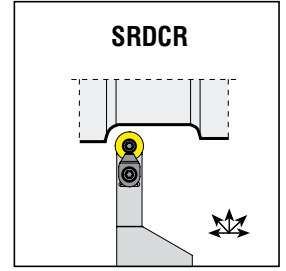
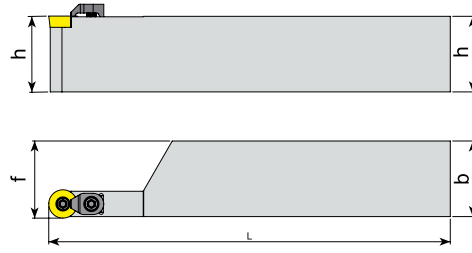

Takım Kodu
Ordering Code

Takım Kodu Ordering Code	Stok Stock		Takım Ölçüleri (mm) Dimension (mm)				Kesici Uç Insert	Yedek Parçaları Spare Parts					
	R	L	h	b	L	f		Sıkma Vidası Screw	Altık Shim	Altık Vidası Shim Screw	Baskı Parçası Wedge Clamp	Baskı Vidası Clamp Screw	Tork Anahtar Torx Key
SRDCR/L 3232 P12C	●	○	32	32	170	32.6							

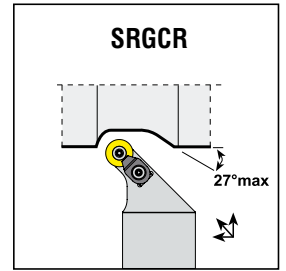
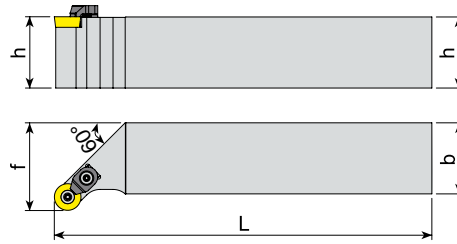

Takım Kodu
Ordering Code

Takım Kodu Ordering Code	Stok Stock		Takım Ölçüleri (mm) Dimension (mm)				Kesici Uç Insert	Yedek Parçaları Spare Parts					
	R	L	h	b	L	f		Sıkma Vidası Screw	Altık Shim	Altık Vidası Shim Screw	Baskı Parçası Wedge Clamp	Baskı Vidası Clamp Screw	Tork Anahtar Torx Key
SRGCR/L 1616 H06	●	●	16	16	100	20	RC.T 0602..	4008-M2.5x6	-	-	-	-	80-T08
2020 K06	●	●	20	20	125	25							
1616 H08C	●	●	16	16	100	20	RC.T 0803..	1008-M3x8	-	-	ACK-15	1015-M3.5x11	80-T15
2020 K08C	●	●	20	20	125	25							
2525 M08C	●	●	25	25	150	32	RC.T 10T3..	4015-M3.5x11	-	-	ACK-05	1515-M4x11	80-T15
1616 H10C	●	●	16	16	100	20							
2020 K10C	●	●	20	20	125	25							
2525 M10C	●	●	25	25	150	32							
3232 P10C	●	●	32	32	170	40	RC.T 1204..	4015-M3.5x11	-	-	ACK-05	1515-M4x11	80-T15
2020 K12C	●	●	20	20	125	25							
2525 M12C	●	●	25	25	150	32							
3232 P12C	●	●	32	32	170	40							

R: Sağ/Right L: Sol/Left ● Stokta/In Stock ○ Stokta Yok/Non Stock Item

Sipariş Örneği/Ordering Example : 1 ad./pcs. SRGCR 1616 H16

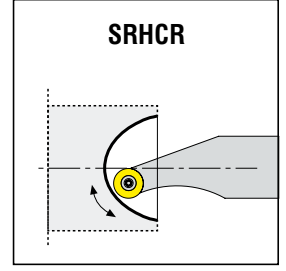
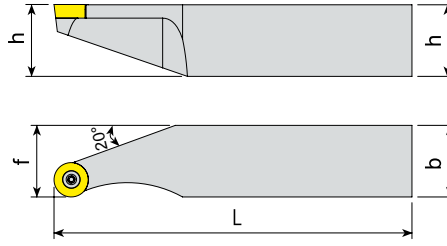

Takım Kodu Ordering Code	Stok Stock		Takım Ölçüleri (mm) Dimension (mm)				Kesici Uç Insert	Yedek Parçaları Spare Parts				
	R	L	h	b	L	f		Sıkma Vidası Screw	Altık Shim	Altık Vidası Shim Screw	Tork Anahtar Torx Key	
SRHCR/L 2525 K08	●	●	25	25	125	25		1008-M3x8	-	-	80-T08	
2525 K10	●	●	25	25	125	25		4015-M3.5x11	-	-	80-T15	
2525 K12	●	●	25	25	125	25		-	-	-	80-T15	
2525 K16	●	●	25	25	125	25		1020-M5x11	-	-	80-T20	

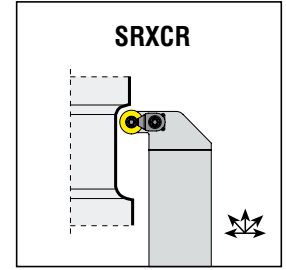
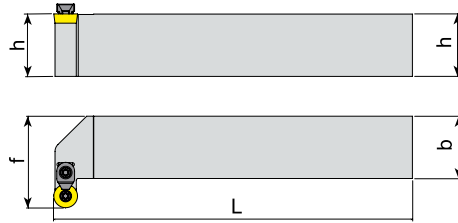

Takım Kodu Ordering Code	Stok Stock		Takım Ölçüleri (mm) Dimension (mm)				Kesici Uç Insert	Yedek Parçaları Spare Parts					
	R	L	h	b	L	f		Sıkma Vidası Screw	Altık Shim	Altık Vidası Shim Screw	Baskı Parçası Wedge Clamp	Baskı Vidası Clamp Screw	Tork Anahtar Torx Key
SRXCR/L 3232 X08C	●	●	32	32	220	47		1008-M3x8	-	-	ACK-15	1015-M3.5x11	80-T08
3232 X10C	●	●	32	32	220	47		4015-M3.5x11	-	-	ACK-05	1015-M3.5x11	80-T15
3232 X12C	●	●	32	32	220	47		-	-	ACK-05	1515-M4x11	80-T15	

R: Sağ/Right L: Sol/Left ● Stokta/In Stock ○ Stokta Yok/Non Stock Item

Sipariş Örneği/Ordering Example : 1 ad./pcs. SRHCR 2525 K08

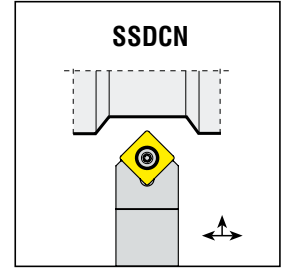
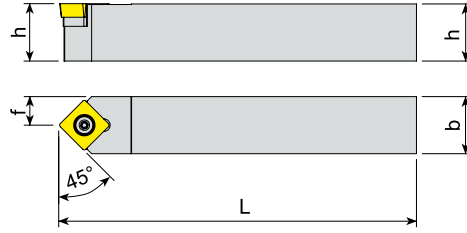

Takım Kodu Ordering Code	Stok Stock	Takım Ölçüleri (mm) Dimension (mm)				Kesici Uç Insert	Yedek Parçaları Spare Parts			
		h	b	L	f		Sıkma Vidası Screw	Altık Shim	Altık Vidası Shim Screw	Tork Anahtar Torx Key
SSDCN 1212 F09	●	12	12	80	6	SC.T 09T3..	4015-M3.5x11	-	-	80-T15
1616 H09	●	16	16	100	8		4015-M3.5x14	AASN-2-0001	AAV-06-M3.5x11	
2020 K09	●	20	20	125	10		4020-M4.5x12	-	AAV-10-M4.5x8	
1616 H12	●	16	16	100	8	SC.T 1204..	1020-M4.5x16	AASN-2-0004	AAV-07-M4.5x13	80-T20
2020 K12	●	20	20	125	10		-	-	-	
2525 M12	●	25	25	150	12.5		-	-	-	

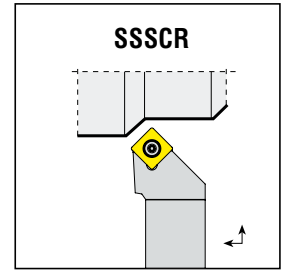
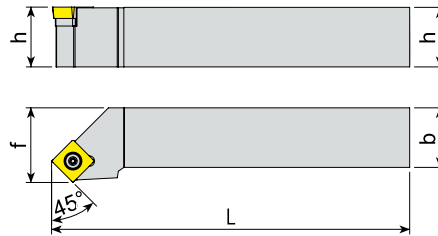

Takım Kodu Ordering Code	Stok Stock		Takım Ölçüleri (mm) Dimension (mm)				Kesici Uç Insert	Yedek Parçaları Spare Parts			
	R	L	h	b	L	f		Sıkma Vidası Screw	Altık Shim	Altık Vidası Shim Screw	Tork Anahtar Torx Key
SSSCR/L 1212 F09	●	●	12	12	80	16	SC.T 09T3..	4015-M3.5x11	-	-	80-T15
1616 H09	●	●	16	16	100	20		4015-M3.5x14	AASN-2-0001	AAV-06-M3.5x11	
2020 K09	●	●	20	20	125	25		4020-M4.5x12	-	AAV-10-M4.5x8	
1616 H12	●	●	16	16	100	20	SC.T 1204..	1020-M4.5x16	AASN-2-0004	AAV-07-M4.5x13	80-T20
2020 K12	●	●	20	20	125	25		-	-	-	
2525 M12	●	●	25	25	150	32		-	-	-	

R: Sağ/Right L: Sol/Left ● Stokta/In Stock ○ Stokta Yok/Non Stock Item

Sipariş Örneği/Ordering Example : 1 ad./pcs. SSDCN 1212 F09

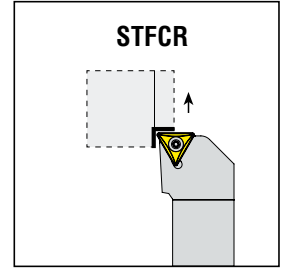
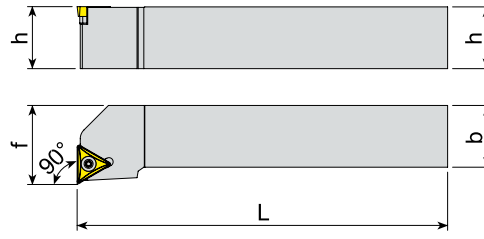

Takım Kodu Ordering Code	Stok Stock		Takım Ölçüleri (mm) Dimension (mm)				Kesici Uç Insert	Yedek Parçaları Spare Parts			
	R	L	h	b	L	f		Sıkma Vidası Screw	Altık Shim	Altık Vidası Shim Screw	Tork Anahtar Torx Key
STFCR/L 0808 E09	○	○	08	08	70	10					
1010 E09	●	●	10	10	70	12					
1212 F11	●	●	12	12	80	16					
1616 H11	●	●	16	16	100	20	TC.T 1102..	4008-M2.5x6	-	-	80-T08
1616 H16	●	●	16	16	100	20					
2020 K16	●	●	20	20	125	25	TC.T 16T3..	4015-M3.5x14	AATN-2-0001	AAV-06-M3.5x11	80-T15
2525 M16	●	●	25	25	150	32					
3232 P16	●	●	32	32	170	40					

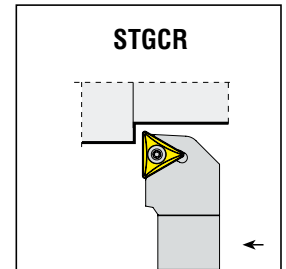
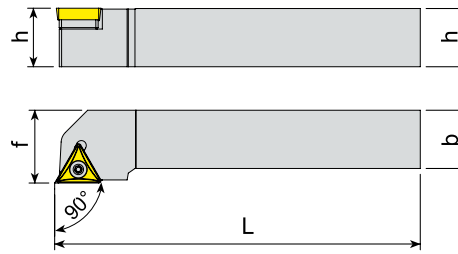

Takım Kodu Ordering Code	Stok Stock		Takım Ölçüleri (mm) Dimension (mm)				Kesici Uç Insert	Yedek Parçaları Spare Parts			
	R	L	h	b	L	f		Sıkma Vidası Screw	Altık Shim	Altık Vidası Shim Screw	Tork Anahtar Torx Key
STGCR/L 0808 E09	●	●	08	08	70	10					
1010 E09	●	●	10	10	70	12					
1212 F11	●	●	12	12	80	16					
1616 H11	●	●	16	16	100	20	TC.T 1102..	4008-M2.5x6	-	-	80-T08
1616 H16	○	○	16	16	100	20					
2020 K16	●	●	20	20	125	25	TC.T 16T3..	4015-M3.5x14	AATN-2-0001	AAV-06-M3.5x11	80-T15
2525 M16	●	●	25	25	150	32					
3232 P16	●	●	32	32	170	40					

R: Sağ/Right L: Sol/Left ● Stokta/In Stock ○ Stokta Yok/Non Stock Item

Sipariş Örneği/Ordering Example : 1 ad./pcs. STFGR 0808 E09

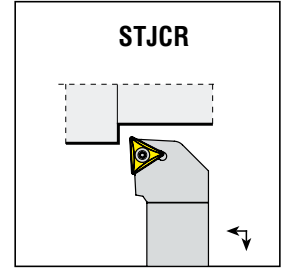
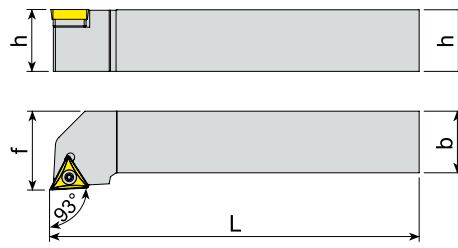

Takım Kodu Ordering Code	Stok Stock		Takım Ölçüleri (mm) Dimension (mm)				Kesici Uç Insert	Yedek Parçaları Spare Parts			
	R	L	h	b	L	f		Sıkma Vidası Screw	Altık Shim	Altık Vidası Shim Screw	Tork Anahtar Torx Key
STJCR/L 0808 E09	●	●	08	08	70	10	TC.T 0902..	3007-M2.2x5	-	-	80-T07
1010 E09	●	●	10	10	70	12					
1212 F11	●	●	12	12	80	16	TC.T 1102..	4008-M2.5x6	-	-	80-T08
1616 H11	●	●	16	16	100	20					
1616 H16	●	●	16	16	100	20	TC.T 16T3..	4015-M3.5x14	AATN-2-0001	AAV-06-M3.5x11	80-T15
2020 K16	●	●	20	20	125	25					
2525 M16	●	●	25	25	150	32					
3232 P16	●	●	32	32	170	40					

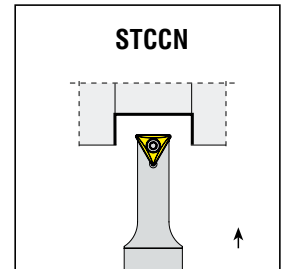
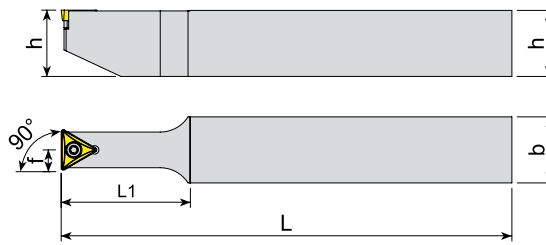

Takım Kodu Ordering Code	Stok Stock		Takım Ölçüleri (mm) Dimension (mm)					Kesici Uç Insert	Yedek Parçaları Spare Parts			
	R	L	h	b	L	f	L1		Sıkma Vidası Screw	Altık Shim	Altık Vidası Shim Screw	Tork Anahtar Torx Key
STCCN 2020 L11	●	●	20	20	140	10	30	TC.T 1102..	4008-M2.5x6	-	-	80-T08
1616 K16	●	●	16	16	125	8	24					
2020 M16	●	●	20	20	150	10	30	TC.T 16T3..	4015-M3.5x14	AATN-2-0001	AAV-06-M3.5x11	80-T15
2525 P16	●	●	25	25	170	12.5	37.5					
3232 R16	●	●	32	32	200	16	48					
2525 P22	●	●	25	25	170	12.5	37.5					
								TC.T 2204..	4020-M4.5x12	-	-	80-T20

R: Sağ/Right L: Sol/Left ● Stokta/In Stock ○ Stokta Yok/Non Stock Item

Sipariş Örneği/Ordering Example : 1 ad./pcs. STJCR 0808 E09

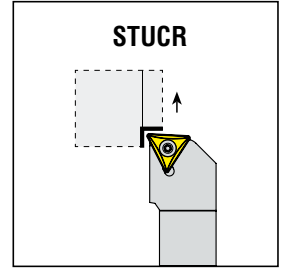
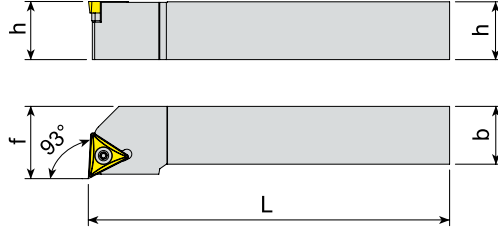

Takım Kodu Ordering Code	Stok Stock		Takım Ölçüleri (mm) Dimension (mm)				Kesici Uç Insert	Yedek Parçaları Spare Parts			
	R	L	h	b	L	f		Sıkma Vidası Screw	Altık Shim	Altık Vidası Shim Screw	Tork Anahtar Torx Key
	STUCR/L 0808 E09	●	●	08	08	70		10	TC.T 0902..	3007-M2.2x5	-
1010 E09	●	●	10	10	70	12					
1212 F11	●	●	12	12	80	16	TC.T 1102..	4008-M2.5x6	-	-	80-T08
1616 H11	●	●	16	16	100	20					
1616 H16	○	○	16	16	100	20	TC.T 16T3..	4015-M3.5x14	AATN-2-0001	AAV-06-M3.5x11	80-T15
2020 K16	●	●	20	20	125	25					
2525 M16	●	●	25	25	150	32					
3232 P16	●	●	32	32	170	40					

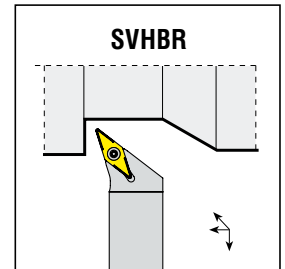
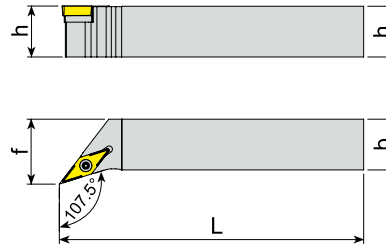

Takım Kodu Ordering Code	Stok Stock		Takım Ölçüleri (mm) Dimension (mm)				Kesici Uç Insert	Yedek Parçaları Spare Parts			
	R	L	h	b	L	f		Sıkma Vidası Screw	Altık Shim	Altık Vidası Shim Screw	Tork Anahtar Torx Key
	SVHBR/L 1212 F11	●	●	12	12	80		16	VBM. 1103..	4008-M2.5x6	-
1616 H11	●	●	16	16	100	20					
2020 K11	●	●	20	20	125	25	VBM. 1604..	4015-M3.5x14	AAVN-2-0002	AAV-06-M3.5x11	80-T15
2020 K16	●	●	20	20	125	25					
2525 M16	●	●	25	25	150	32					
3232 P16	●	●	32	32	170	40					

R: Sağ/Right L: Sol/Left ● Stokta/In Stock ○ Stokta Yok/Non Stock Item

Sipariş Örneği/Ordering Example : 1 ad./pcs. STUCR 0808 E09

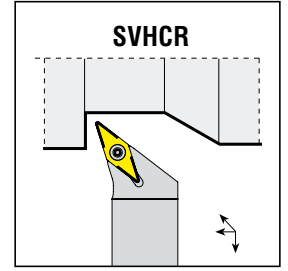
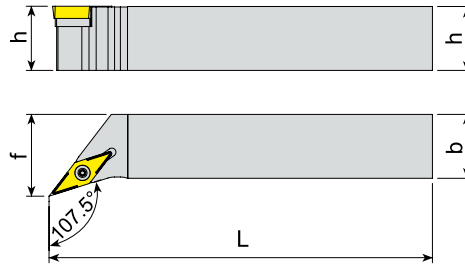
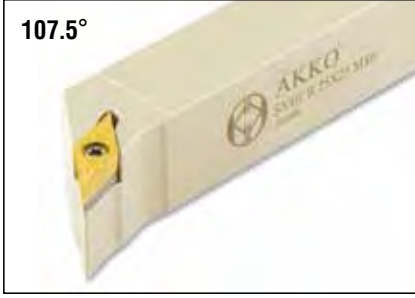

Takım Kodu Ordering Code	Stok Stock		Takım Ölçüleri (mm) Dimension (mm)				Kesici Uç Insert	Yedek Parçaları Spare Parts			
	R	L	h	b	L	f		Sıkma Vidası Screw	Altılık Shim	Altılık Vidası Shim Screw	Tork Anahtar Torx Key
SVHCR/L 1212 F11	●	●	12	12	80	16	VC.T 1103..	4008-M2.5x6	-	-	80-T08
1616 H11	●	●	16	16	100	20					
2020 K11	●	●	20	20	125	25					
2020 K16	●	●	20	20	125	25	VC.T 1604..	4015-M3.5x14	AAVN-2-0002	AAV-06-M3.5x11	80-T15
2525 M16	●	●	25	25	150	32					
3232 P16	●	●	32	32	170	40					

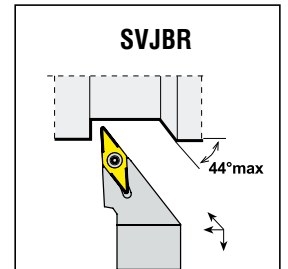
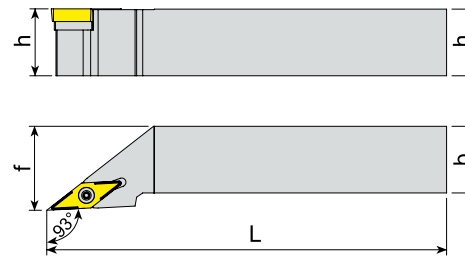

Takım Kodu Ordering Code	Stok Stock		Takım Ölçüleri (mm) Dimension (mm)				Kesici Uç Insert	Yedek Parçaları Spare Parts			
	R	L	h	b	L	f		Sıkma Vidası Screw	Altılık Shim	Altılık Vidası Shim Screw	Tork Anahtar Torx Key
SVJBR/L 1212 F11	●	●	12	12	80	16	VBM. 1103..	4008-M2.5x6	-	-	80-T08
1616 H11	●	●	16	16	100	20					
2020 K11	●	●	20	20	125	25					
1616 H16	●	●	16	16	100	20	VBM. 1604..	4015-M3.5x14	AAVN-2-0002	AAV-06-M3.5x11	80-T15
2020 K16	●	●	20	20	125	25					
2525 M16	●	●	25	25	150	32					
3232 P16	●	●	32	32	170	40					

R: Sağ/Right L: Sol/Left ● Stokta/In Stock ○ Stokta Yok/Non Stock Item

Sipariş Örneği/Ordering Example : 1 ad./pcs. SVHCR 1212 F11

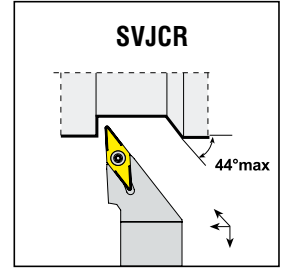
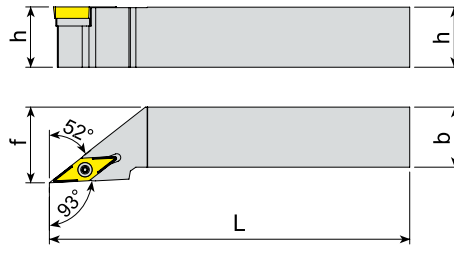

Takım Kodu Ordering Code	Stok Stock		Takım Ölçüleri (mm) Dimension (mm)				Kesici Uç Insert	Yedek Parçaları Spare Parts			
	R	L	h	b	L	f		Sıkma Vidası Screw	Altık Shim	Altık Vidası Shim Screw	Tork Anahtar Torx Key
SVJCR/L 1212 F11	●	●	12	12	80	16	VC.T 1103..	4008-M2.5x6	-	-	80-T08
1616 H11	●	●	16	16	100	20					
2020 K11	●	●	20	20	125	25					
1212 F16	●	○	12	12	80	16	VC.T 1604..	4015-M3.5x14	AAVN-2-0002	AAV-06-M3.5x11	80-T15
2020 K16	●	●	20	20	125	25					
2525 M16	●	●	25	25	150	32					
3232 P16	●	●	32	32	170	40					

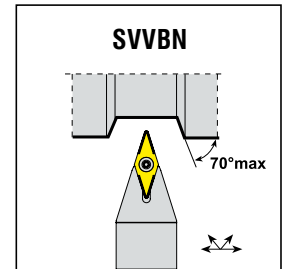
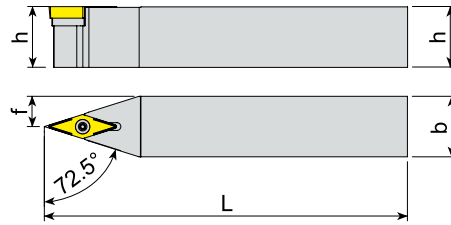

Takım Kodu Ordering Code	Stok Stock		Takım Ölçüleri (mm) Dimension (mm)				Kesici Uç Insert	Yedek Parçaları Spare Parts			
	R	L	h	b	L	f		Sıkma Vidası Screw	Altık Shim	Altık Vidası Shim Screw	Tork Anahtar Torx Key
SVVBN 1212 F11	●		12	12	80	06	VBM. 1103..	4008-M2.5x6	-	-	80-T08
1616 H11	●		16	16	100	08					
2020 K11	●		20	20	125	10					
2020 K16	●		20	20	125	10	VBM. 1604..	4015-M3.5x14	AAVN-2-0002	AAV-06-M3.5x11	80-T15
2525 M16	●		25	25	150	12.5					
3232 P16	●		32	32	170	16					

R: Sağ/Right L: Sol/Left ● Stokta/In Stock ○ Stokta Yok/Non Stock Item

Sipariş Örneği/Ordering Example : 1 ad./pcs. SVJCR 1212 F11

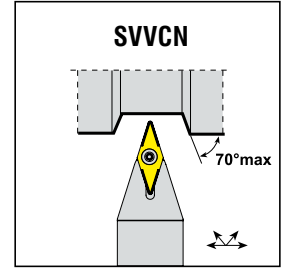
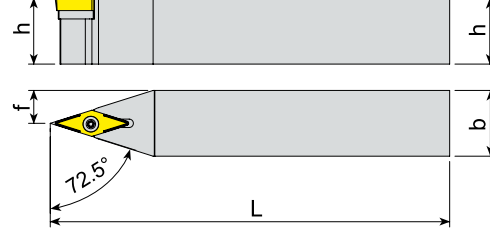

Takım Kodu Ordering Code	Stok Stock	Takım Ölçüleri (mm) Dimension (mm)				Kesici Uç Insert	Yedek Parçaları Spare Parts			
		h	b	L	f		Sıkma Vidası Screw	Altık Shim	Altık Vidası Shim Screw	Tork Anahtar Torx Key
SVVCN 1212 F11	●	12	12	80	06	VC.T 1103..	4008-M2.5x6	-	-	80-T08
1616 H11	●	16	16	100	08					
2020 K11	●	20	20	125	10					
2020 K16	●	20	20	125	10	VC.T 1604..	4015-M3.5x14	AAVN-2-0002	AAV-06-M3.5x11	80-T15
2525 M16	●	25	25	150	12.5					
3232 P16	●	32	32	170	16					

S-SİSTEM İSVEÇ TİPİ KAYAR OTOMAT MAKİNA TAKIMLARI
S-SYSTEM TOOLS FOR SWISS TYPE SLIDING AUTOMATIC LATHES

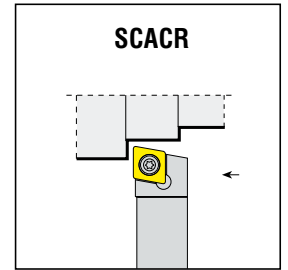
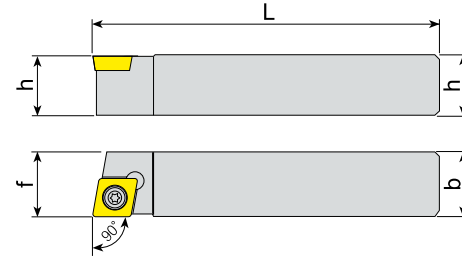

Takım Kodu Ordering Code	Stok Stock		Takım Ölçüleri (mm) Dimension (mm)				Kesici Uç Insert	Yedek Parçaları Spare Parts			
	R	L	h	b	L	f		Sıkma Vidası Screw	Altık Shim	Altık Vidası Shim Screw	Tork Anahtar Torx Key
SCACR/L 0808 X06-S	○	○	08	08	115	08	CCM. 0602..	4008-M2.5x6	-	-	80-T08
1010 K06-S	●	○	10	10	125	10					
1212 G06-S	○	○	12	12	90	12					
1212 K06-S	○	○	12	12	125	12					
1616 F06-S	○	○	16	16	75	16					
1616 K06-S	○	○	16	16	125	16	CCM. 09T3..	4015-M3.5x11	-	-	80-T15
1212 G09-S	○	○	12	12	90	12					
1212 K09-S	●	●	12	12	125	12					
1616 F09-S	○	○	16	16	75	16					
1616 K09-S	●	●	16	16	125	16					
2020 K09-S	●	●	20	20	125	20					

R: Sağ/Right L: Sol/Left ● Stokta/In Stock ○ Stokta Yok/Non Stock Item

Sipariş Örneği/Ordering Example : 1 ad./pcs. SCACR 1010 K06-S

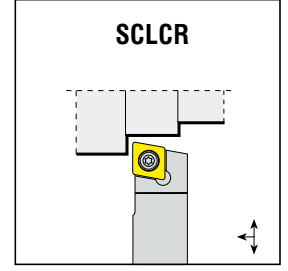
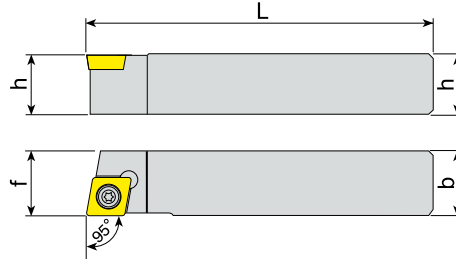

Takım Kodu Ordering Code	Stok Stock		Takım Ölçüleri (mm) Dimension (mm)				Kesici Uç Insert	Yedek Parçaları Spare Parts			
	R	L	h	b	L	f		Sıkma Vidası Screw	Altık Shim	Altık Vidası Shim Screw	Tork Anahtar Torx Key
SCLCR/L 0808 X06-S	●	●	08	08	115	08					80-T08
1010 X06-S	●	○	10	10	115	10					
1212 G06-S	●	○	12	12	90	12					
1212 X06-S	●	○	12	12	115	12					
1616 F06-S	●	○	16	16	75	16					
1616 X06-S	●	○	16	16	115	16					
1212 G09-S	●	○	12	12	90	12					80-T15
1212 X09-S	●	○	12	12	115	12					
1616 F09-S	●	○	16	16	75	16					
1616 X09-S	●	○	16	16	115	16					
2020 X09-S	●	○	20	20	115	20					

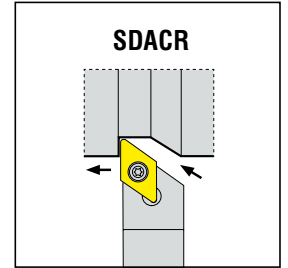
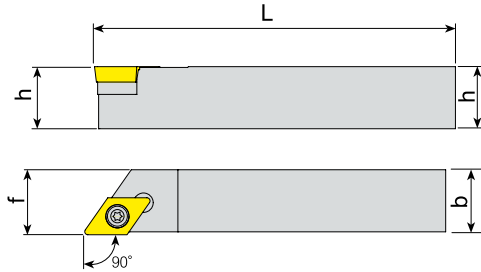

Takım Kodu Ordering Code	Stok Stock		Takım Ölçüleri (mm) Dimension (mm)				Kesici Uç Insert	Yedek Parçaları Spare Parts			
	R	L	h	b	L	f		Sıkma Vidası Screw	Altık Shim	Altık Vidası Shim Screw	Tork Anahtar Torx Key
SDACR/L 0808 X07-S	○	○	08	08	115	08					80-T08
1010 K07-S	●	●	10	10	125	10					
1212 G07-S	○	○	12	12	90	12					
1212 K07-S	●	○	12	12	125	12					
1616 F07-S	○	○	16	16	75	16					
1616 K07-S	●	○	16	16	125	16					
1212 G11-S	○	○	12	12	90	12					80-T15
1212 K11-S	●	●	12	12	125	12					
1616 F11-S	○	○	16	16	75	16					
1616 K11-S	●	●	16	16	125	16					
2020 K11-S	●	●	20	20	125	20					

R: Sağ/Right L: Sol/Left ● Stokta/In Stock ○ Stokta Yok/Non Stock Item

Sipariş Örneği/Ordering Example : 1 ad./pcs. SCACR 1010 K06-S

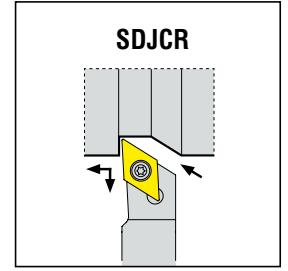
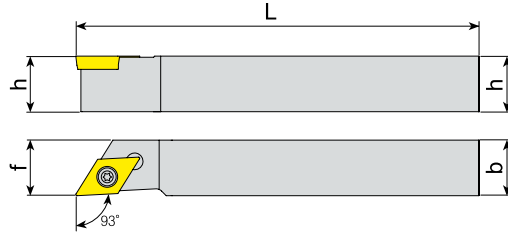

Takım Kodu Ordering Code	Stok Stock		Takım Ölçüleri (mm) Dimension (mm)				Kesici Uç Insert	Yedek Parçaları Spare Parts			
	R	L	h	b	L	f		Sıkma Vidası Screw	Altık Shim	Altık Vidası Shim Screw	Tork Anahtar Torx Key
SDJCR/L 0808 X07-S	●	○	08	08	115	08	DC.T 0702..				
1010 X07-S	●	○	10	10	115	10					
1212 G07-S	●	○	12	12	90	12					
1212 X07-S	●	○	12	12	115	12					
1616 F07-S	●	○	16	16	75	16					
1616 X07-S	●	○	16	16	115	16					
2020 X07-S	●	○	20	20	115	20					
1212 G11-S	●	○	12	12	90	12	DC.T 11T3..				
1212 X11-S	●	●	12	12	115	12					
1212 K11-S	●	○	12	12	125	12					
1616 F11-S	●	○	16	16	75	16					
1616 X11-S	●	○	16	16	115	16					
1616 K11-S	●	●	16	16	125	16					
2020 X11-S	●	○	20	20	115	20					

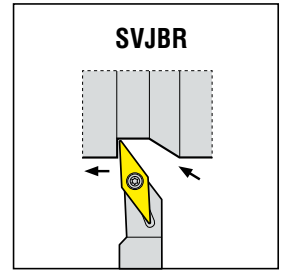
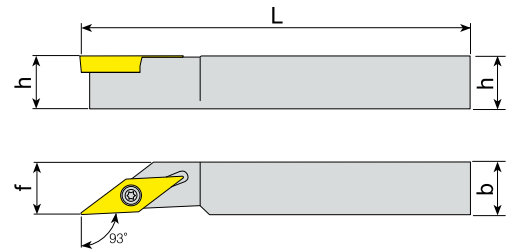

Takım Kodu Ordering Code	Stok Stock		Takım Ölçüleri (mm) Dimension (mm)				Kesici Uç Insert	Yedek Parçaları Spare Parts			
	R	L	h	b	L	f		Sıkma Vidası Screw	Altık Shim	Altık Vidası Shim Screw	Tork Anahtar Torx Key
SVJBR/L 1616 K11-S	●	●	16	16	125	16	VBM. 1103..				

R: Sağ/Right L: Sol/Left ● Stokta/In Stock ○ Stokta Yok/Non Stock Item

Sipariş Örneği/Ordering Example : 1 ad./pcs. SDJCR 1212 K11-S

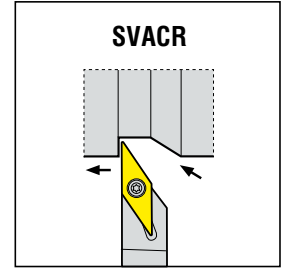
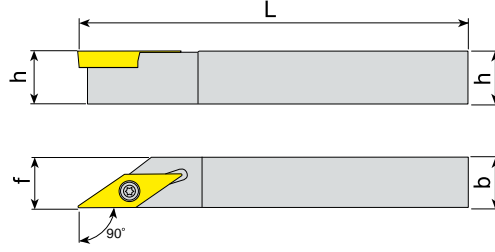

Takım Kodu Ordering Code	Stok Stock		Takım Ölçüleri (mm) Dimension (mm)				Kesici Uç Insert	Yedek Parçaları Spare Parts			
	R	L	h	b	L	f		Sıkma Vidası Screw	Altık Shim	Altık Vidası Shim Screw	Tork Anahtar Torx Key
SVACR/L 0808 X11-S	○	○	08	08	115	08	VC.T 1103..	4008-M2.5x6	-	-	80-T08
1010 K11-S	●	○	10	10	125	10					
1212 G11-S	○	○	12	12	90	12					
1212 K11-S	●	●	12	12	125	12					
1616 F11-S	○	○	16	16	75	16					
1616 K11-S	●	●	16	16	125	16					
2020 K11-S	●	●	20	20	125	20					
1212 K16-S	●	○	12	12	125	12	VC.T 1604..	4015-M3.5x11		80-T15	
1616 K16-S	●	○	16	16	125	16					

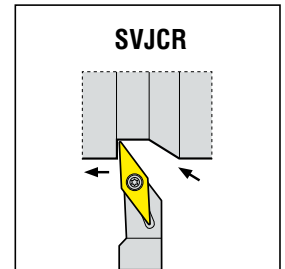
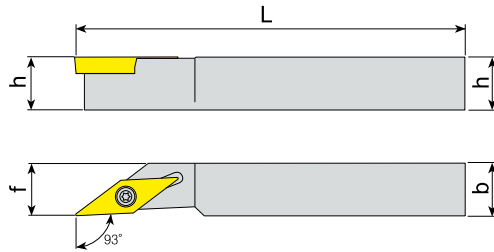

Takım Kodu Ordering Code	Stok Stock		Takım Ölçüleri (mm) Dimension (mm)				Kesici Uç Insert	Yedek Parçaları Spare Parts			
	R	L	h	b	L	f		Sıkma Vidası Screw	Altık Shim	Altık Vidası Shim Screw	Tork Anahtar Torx Key
SVJCR/L 0808 X11-S	●	○	08	08	115	08	VC.T 1103..	4008-M2.5x6	-	-	80-T08
1010 K11-S	○	○	10	10	125	10					
1212 G11-S	○	○	12	12	90	12					
1212 K11-S	●	●	12	12	125	12					
1616 F11-S	○	○	16	16	75	16					
1616 K11-S	○	○	16	16	125	16					
2020 K11-S	○	○	20	20	125	20					

R: Sağ/Right L: Sol/Left ● Stokta/In Stock ○ Stokta Yok/Non Stock Item

Sipariş Örneği/Ordering Example : 1 ad./pcs. SVJBR 1616 K11-S

DELİK TORNA TAKIMLARI
INTERNAL TURNING TOOLHOLDERS





1 Takım Malzemesi / Type of Boring Bar

"A" Yekpare çelik gövde soğutma suyu kanallı / "A" Solid steel with coolant hole
 "E" Çelik başlıkla sert metal gövde ve soğutma suyu kanallı /
 "E" Carbide bar with fixed steel head and coolant hole
 "C" Karbür Şaft / "C" Carbide shank
 "S" Çelik Şaft / "S" Steel shank

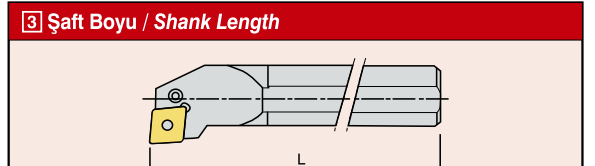
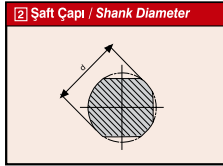

4 Sıkma Tipi / Method of Mounting of Insert

Deliksiz Üstten Sıkma Top clamping without hole	Üstten Delikle Sıkma Top and Hole Clamping	Üstten ve Delikten Sıkma Top and Hole Clamping	Delikten Laye ile Sıkma Hole Clamping (Lever Lock)	Vida ile Sıkma Screw on
C	T	M	P	S

A-32	H-100	Q-180	x-special
B-40	J-110	R-200	
C-50	K-125	S-250	
D-60	L-140	T-300	
E-70	M-150	U-350	
F-80	N-160	V-400	
G-90	P-170	W-450	

(mm)

5 Uç Tipi / Insert Shape

C	D	E
V	R	S
W	K	T

6 Yanaşma Açısı / Tool Holder Shape Bar Geometry

7 Serbest Uç Açısı / Insert Clearance Angle

8 Kesme Yönü / Cutting Direction

9 Kesme Kenar Uzunluğu / Cutting Edge Length

10 Baskı Pabucu / Wedge Clamp

T&C-SİSTEM

T&C SİSTEM DELİK TORNA KATERLERİ
T&C SYSTEM BORING BARS

*konusulan
the spoken kalite...
quality...*



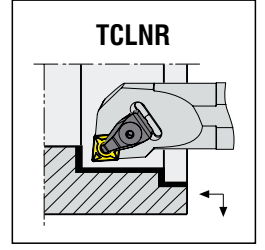
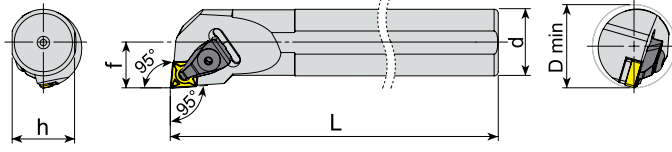

Takım Kodu Ordering Code	Takım Ölçüleri (mm) Dimension (mm)						Kesici Uç Insert	Yedek Parçaları Spare Parts							
	Stok Stock		d	h	L	f		D min	Baskı Pabucu Wedge Clamp	Pabuç Vidası Clamp Screw	Altık Shim	Altık Vidası Shim Screw	Yay Spring	Pul Stamp	Anahtar Allen Key
	R	L							ATK-01	AKV-01-M5x22	AACN-2-0001	AAV-09-M5x9	-	-	
S25S TCLNR/L 09	●●	25	23	250	17	≥32	CNM. 0903..	ATK-01	AKV-01-M5x22	AACN-2-0001	AAV-09-M5x9	-	-	-	
S25S TCLNR/L 12	●●	25	23	250	17	≥32	CNM. 1204..	ATK-02	AKV-02-M6x22	AACN-3-0001	AAV-13-M5x8	AKY-01	ABPL-01	AAL-03-3	
S32T TCLNR/L 12	●●	32	30	300	22	≥40					AAV-02-M5x12				
S40U TCLNR/L 12	●●	40	37.5	350	27	≥50									
S50V TCLNR/L 12	●●	50	47	400	35	≥63	CNM. 1606..	ATK-04	AKV-19-M7x25	AACN-3-0002	AAV-05-M6x15	-	ABPL-02	AAL-05-4	
S32T TCLNR/L 16	●●	32	30	300	22	≥40									
S40U TCLNR/L 16	●●	40	37.5	350	27	≥50									
S50V TCLNR/L 16	●●	50	47	400	35	≥63									

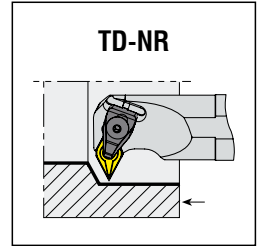
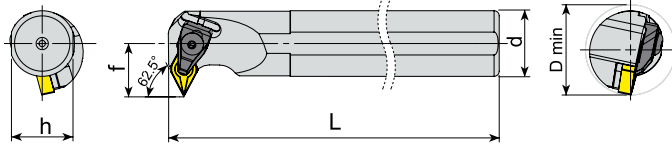

Takım Kodu Ordering Code	Takım Ölçüleri (mm) Dimension (mm)						Kesici Uç Insert	Yedek Parçaları Spare Parts							
	Stok Stock		d	h	L	f		D min	Baskı Pabucu Wedge Clamp	Pabuç Vidası Clamp Screw	Altık Shim	Altık Vidası Shim Screw	Yay Spring	Pul Stamp	Anahtar Allen Key
	R	L							ATK-02	AKV-02-M6x22	AADN-3-0001	AAV-02-M5x12	AKY-01 <td>ABPL-01</td> <td>AAL-03-3</td>	ABPL-01	AAL-03-3
S32T TD-NR/L 15	●●	32	30	300	26	≥44	DNM. 1506..	ATK-02	AKV-02-M6x22	AADN-3-0001	AAV-02-M5x12	AKY-01	ABPL-01	AAL-03-3	
S40U TD-NR/L 15	●●	40	37.5	350	29	≥52									
S50V TD-NR/L 15	●●	50	47	400	35	≥67									

R: Sağ/Right L: Sol/Left ● Stokta/In Stock ○ Stokta Yok/Non Stock Item

Sipariş Örneği/Ordering Example : 1 ad./pcs. S25S TCLNR 09

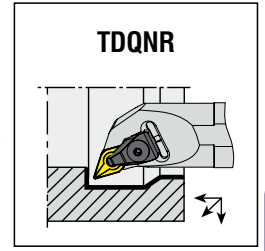
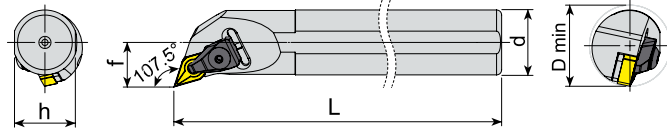

Takım Kodu Ordering Code	Stok Stock		Takım Ölçüleri (mm) Dimension (mm)					Kesici Uç Insert	Yedek Parçaları Spare Parts						
	R	L	d	h	L	f	D min		Baskı Pabucu Wedge Clamp	Pabuç Vidası Clamp Screw	Altılık Shim	Altılık Vidası Shim Screw	Yay Spring	Pul Stamp	Anahtar Allen Key
	S25S TDQNR/L 11	●	●	25	23	250	17		≥32	DNM. 1104..	ATK-01	AKV-01-M5x22	AADN -2-0001	AAV-09-M5x9	-
S32T TDQNR/L 11	●	●	32	30	300	22	≥40	AAV-04-M5x12							
S32T TDQNR/L 15	●	●	32	30	300	22	≥40	DNM. 1506..	ATK-02	AKV-02-M6x22	AADN -3-0001	AAV-02-M5x12	AKY-01		
S40U TDQNR/L 15	●	●	40	37.5	350	27	≥50								
S50V TDQNR/L 15	●	●	50	47	400	35	≥63								

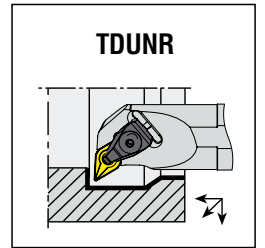
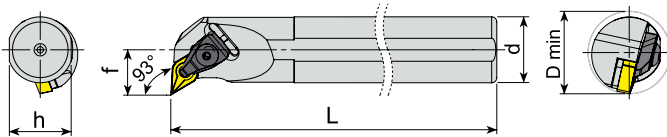

Takım Kodu Ordering Code	Stok Stock		Takım Ölçüleri (mm) Dimension (mm)					Kesici Uç Insert	Yedek Parçaları Spare Parts						
	R	L	d	h	L	f	D min		Baskı Pabucu Wedge Clamp	Pabuç Vidası Clamp Screw	Altılık Shim	Altılık Vidası Shim Screw	Yay Spring	Pul Stamp	Anahtar Allen Key
	S25S TDUNR/L 11	●	●	25	23	250	17		≥32	DNM. 1104..	ATK-01	AKV-01-M5x22	AADN -2-0001	AAV-09-M5x9	-
S32T TDUNR/L 11	●	●	32	30	300	22	≥40	AAV-04-M5x12							
S25S TDUNR/L 15	●	●	25	23	250	17	≥32	DNM. 1506..	ATK-02	AKV-02-M6x22	AADN -3-0001	AAV-13-M5x8	AKY-01		
S32T TDUNR/L 15	●	●	32	30	300	22	≥40								
S40U TDUNR/L 15	●	●	40	37.5	350	27	≥50								
S50V TDUNR/L 15	●	●	50	47	400	35	≥63								

R: Sağ/Right L: Sol/Left ●Stokta/In Stock ○Stokta Yok/Non Stock Item

Sipariş Örneği/Ordering Example : 1 ad./pcs. S25S TDQNR 11

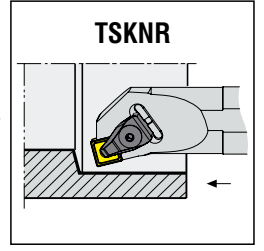
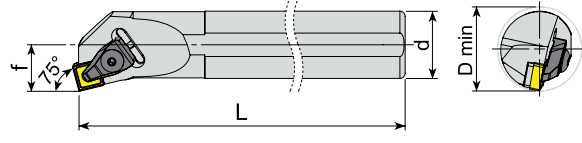
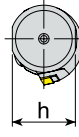

Takım Kodu Ordering Code	Stok Stock		Takım Ölçüleri (mm) Dimension (mm)				Kesici Uç Insert	Yedek Parçaları Spare Parts							
	R	L	d	h	L	f		D min	Baskı Pabucu Wedge Clamp	Pabuç Vidası Clamp Screw	Altılık Shim	Altılık Vidası Shim Screw	Yay Spring	Pul Stamp	Anahtar Allen Key
S25S TSKNR/L 12	●	●	25	23	250	17	≥32	SNM. 1204..	ATK-02	AKV-02-M6x22	AASN-3-0004	AAV-13-M5x8	AKY-01	ABPL-01	AAL-03-3
S32T TSKNR/L 12	●	●	32	30	300	22	≥40					AAV-02-M5x12			
S40U TSKNR/L 12	●	●	40	37.5	350	27	≥50								

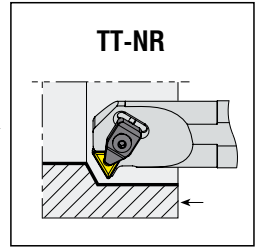
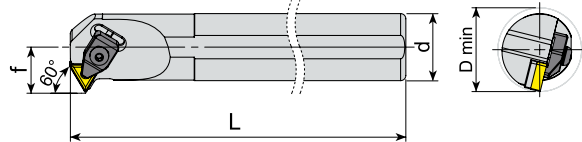
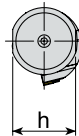

Takım Kodu Ordering Code	Stok Stock		Takım Ölçüleri (mm) Dimension (mm)				Kesici Uç Insert	Yedek Parçaları Spare Parts							
	R	L	d	h	L	f		D min	Baskı Pabucu Wedge Clamp	Pabuç Vidası Clamp Screw	Altılık Shim	Altılık Vidası Shim Screw	Yay Spring	Pul Stamp	Anahtar Allen Key
S25S TT-NR/L 16	●	●	25	23	250	17	≥32	TNM. 1604..	ATK-01	AKV-01-M5x22	AATN-2-0002	AAV-03-M5x12	-	ABPL-01	AAL-03-3
S32T TT-NR/L 16	●	●	32	30	300	22	≥40								

R: Sağ/Right L: Sol/Left ● Stokta/In Stock ○ Stokta Yok/Non Stock Item

Sipariş Örneği/Ordering Example : 1 ad./pcs. S25S TSKNR 12

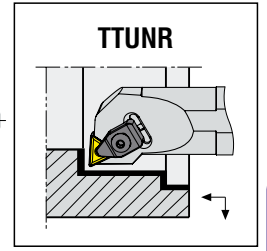
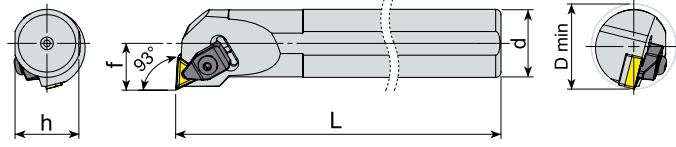

Takım Kodu Ordering Code	Stok Stock		Takım Ölçüleri (mm) Dimension (mm)					Kesici Uç Insert	Yedek Parçaları Spare Parts						
	R	L	d	h	L	f	D min		Baskı Pabucu Wedge Clamp	Pabuç Vidası Clamp Screw	Altık Shim	Altık Vidası Shim Screw	Yay Spring	Pul Stamp	Anahtar Allen Key
S25S TTUNR/L 16	●	●	25	23	250	17	≥32	TNM. 1604..	ATK-01	AKV-01-M5x22	AATN-2-0002	AAV-03-M5x12	-	ABPL-01	AAL-03-3
S32T TTUNR/L 16	●	●	32	30	300	22	≥40								
S25S TTUNR/L 22	●	●	25	23	250	17	≥32	TNM. 2204..	ATK-02	AKV-02-M6x22	AATN-3-0015	AAV-02-M5x12	AKY-01	ABPL-01	AAL-03-3
S32T TTUNR/L 22	●	●	32	30	300	22	≥40								
S40U TTUNR/L 22	●	●	40	37.5	350	27	≥50								
S50V TTUNR/L 22	●	●	50	47	400	35	≥63								

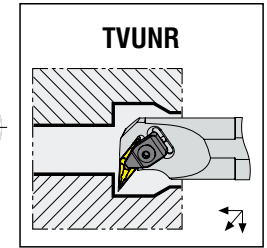
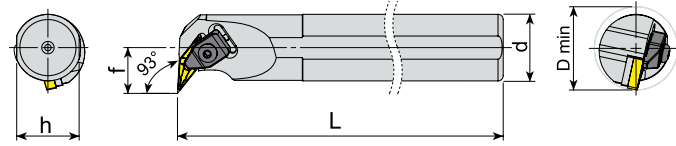

Takım Kodu Ordering Code	Stok Stock		Takım Ölçüleri (mm) Dimension (mm)					Kesici Uç Insert	Yedek Parçaları Spare Parts						
	R	L	d	h	L	f	D min		Baskı Pabucu Wedge Clamp	Pabuç Vidası Clamp Screw	Altık Shim	Altık Vidası Shim Screw	Yay Spring	Pul Stamp	Anahtar Allen Key
S25S TVUNR/L 16	●	●	25	23	250	20	≥36	VNM. 1604..	ATK-01	AKV-01-M5x22	AAVN-2-0002	AAV-04-M5x12	-	ABPL-01	AAL-03-3
S32T TVUNR/L 16	●	●	32	30	300	22	≥40								
S40U TVUNR/L 16	●	●	40	37.5	350	27	≥50								

R: Sağ/Right L: Sol/Left ● Stokta/In Stock ○ Stokta Yok/Non Stock Item

Sipariş Örneği/Ordering Example : 1 ad./pcs. S25S TTUNR 16

➤ T-SİSTEM DELİK TORNA KATERLERİ
T-SYSTEM BORING BARS

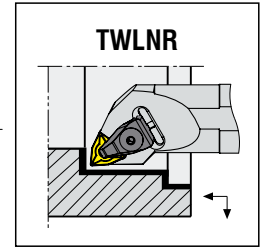
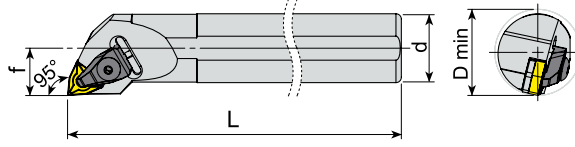
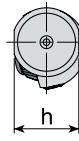

Takım Kodu Ordering Code	Stok Stock		Takım Ölçüleri (mm) Dimension (mm)				Kesici Uç Insert	Yedek Parçaları Spare Parts							
	R	L	d	h	L	f		D min	Baskı Pabucu Wedge Clamp	Pabuç Vidası Clamp Screw	Altılık Shim	Altılık Vidası Shim Screw	Yay Spring	Pul Stamp	Anahtar Allen Key
S25S TWLNR/L 06	●	●	25	23	250	17	≥32	WNM. 0604..	ATK-01	AKV-01-M5x22	AAWN-SW317	AAV-01-M3x10	-	ABPL-01	AAL-03-3
S32T TWLNR/L 06	●	●	32	30	300	22	≥40					AAV-13-M5x8			
S25S TWLNR/L 08	●	●	25	23	250	17	≥32	WNM. 0804..	ATK-02	AKV-02-M6x22	AAWN-3-0001	AAV-02-M5x12	AKY-01	ABPL-01	AAL-03-3
S32T TWLNR/L 08	●	●	32	30	300	22	≥40								
S40U TWLNR/L 08	●	●	40	37.5	350	27	≥50								
S50V TWLNR/L 08	●	●	50	47	400	35	≥63								

➤ C-SİSTEM DELİK TORNA KATERLERİ
C-SYSTEM BORING BARS

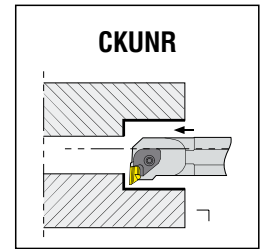
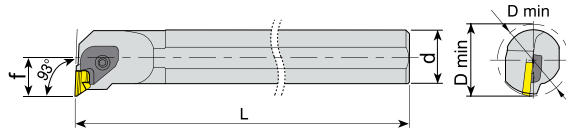
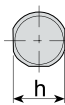

Takım Kodu Ordering Code	Stok Stock		Takım Ölçüleri (mm) Dimension (mm)				Kesici Uç Insert	Yedek Parçaları Spare Parts							
	R	L	d	h	L	f		D min	Baskı Pabucu Wedge Clamp	Pabuç Vidası Clamp Screw	Altılık Shim	Altılık Vidası Shim Screw	Yay Spring	Pul Stamp	Anahtar Allen Key
S25S CKUNR/L 16	●	●	25	23	250	19	≥38	KNUX 1604..	ACK-01-R ACK-02-L	AKV-06-M6x20	AKS-16-R AKS-16-L	AAV-01-M3x10	AKY-02	ABPL-01	AAL-05-4
S32T CKUNR/L 16	●	●	32	30	300	22	≥40								
S40U CKUNR/L 16	●	●	40	37.5	350	27	≥50								
S50V CKUNR/L 16	●	●	50	47	400	35	≥63								

R: Sağ/Right L: Sol/Left ● Stokta/In Stock ○ Stokta Yok/Non Stock Item

Sipariş Örneği/Ordering Example : 1 ad./pcs. S25S TWLNR 06

M-SİSTEM

M-SİSTEM DELİK TORNA KATERLERİ
M-SYSTEM BORING BARS

*konusulan
the spoken kalite...
quality...*



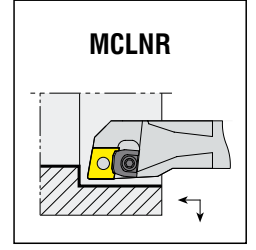
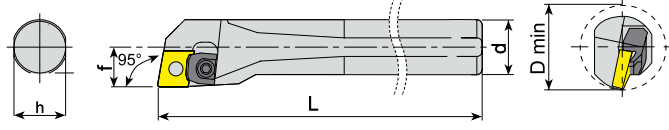

Takım Kodu Ordering Code	Stok Stock		Takım Ölçüleri (mm) Dimension (mm)					Kesici Uç Insert	Yedek Parçaları Spare Parts					
	R	L	d	h	L	f	D min		Baskı Pabucu Wedge Clamp	Pabuç Vidası Clamp Screw	Altlık Shim	Pim Pin	Pul Stamp	Anahtar Allen Key
S20R MCLNR/L 12	●	●	20	18.3	200	13	≥25	CNM. 1204..	AMK-07	AKV-04-M5x17	-	APM-12	-	AAL-03-3
S25S MCLNR/L 12	●	●	25	23	250	17	≥32		AMK-03		AACN-3-0001	APM-13		
S32T MCLNR/L 12	●	●	32	30	300	22	≥40					APM-04		

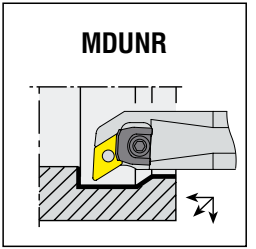
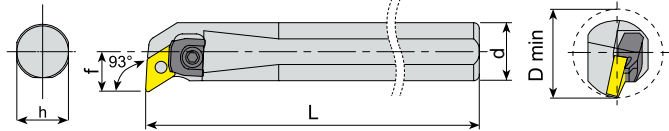

Takım Kodu Ordering Code	Stok Stock		Takım Ölçüleri (mm) Dimension (mm)					Kesici Uç Insert	Yedek Parçaları Spare Parts					
	R	L	d	h	L	f	D min		Baskı Pabucu Wedge Clamp	Pabuç Vidası Clamp Screw	Altlık Shim	Pim Pin	Pul Stamp	Anahtar Allen Key
S20R MDUNR/L 11	●	●	20	18.3	200	13	≥25	DNM. 1104..	AMK-03	AKV-17-M5x15	-	APM-03	-	AAL-03-3
S25S MDUNR/L 11	●	●	25	23	250	17	≥32			AKV-04-M5x17				
S32T MDUNR/L 11	○	○	32	30	300	22	≥40							
S25S MDUNR/L 15	●	●	25	23	250	17	≥32	DNM. 1506..	AMK-04	AKV-20-M6x19	AADN-3-0001	APM-04	ABPL-01	AAL-03-3
S32T MDUNR/L 15	●	●	32	30	300	22	≥40			AKV-02-M6x22				
S40U MDUNR/L 15	●	●	40	37.5	350	27	≥50							
S50V MDUNR/L 15	●	●	50	47	400	35	≥63							

R: Sağ/Right L: Sol/Left ● Stokta/In Stock ○ Stokta Yok/Non Stock Item

Sipariş Örneği/Ordering Example : 1 ad./pcs. S20R MCLNR 12

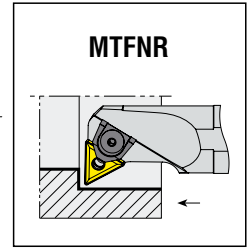
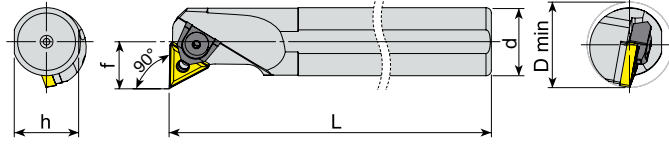

Takım Kodu Ordering Code	Stok Stock		Takım Ölçüleri (mm) Dimension (mm)					Kesici Uç Insert	Yedek Parçaları Spare Parts						
	R	L	d	h	L	f	D min		Baskı Pabucu Wedge Clamp	Pabuç Vidası Clamp Screw	Altlık Shim	Pim Pin	Pul Stamp	Anahtar Allen Key	
S20R MTFNR/L 16	●	●	20	18.3	200	14	≥25	TNM. 1604..	AMK-02	AKV-17-M5x15	-	APM-03	-	ABPL-01	AAL-03-3
S25S MTFNR/L 16	●	●	25	23	250	17	≥32				AATN-2-0002	APM-14			
S32T MTFNR/L 16	●	●	32	30	300	22	≥40					APM-01			
S40U MTFNR/L 16	●	○	40	37.5	350	27	≥50	TNM. 2204..	AMK-04	AKV-02-M6x22					
S32T MTFNR/L 22	●	●	32	30	300	22	≥40				AATN-3-0015	APM-02			
S40U MTFNR/L 22	●	○	40	37.5	350	27	≥50								
S50V MTFNR/L 22	○	○	50	47	400	35	≥63								

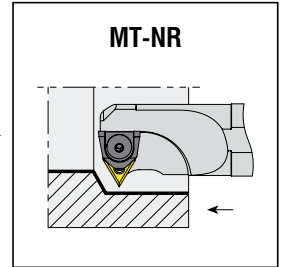
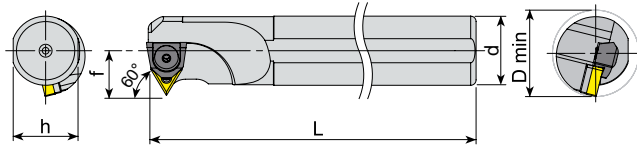

Takım Kodu Ordering Code	Stok Stock		Takım Ölçüleri (mm) Dimension (mm)					Kesici Uç Insert	Yedek Parçaları Spare Parts						
	R	L	d	h	L	f	D min		Baskı Pabucu Wedge Clamp	Pabuç Vidası Clamp Screw	Altlık Shim	Pim Pin	Pul Stamp	Anahtar Allen Key	
S20R MT-NR/L 16	●	●	20	18.3	200	16	≥26	TNM. 1604..	AMK-02	AKV-04-M5x17	-	APM-03	-	ABPL-01	AAL-03-3
S25S MT-NR/L 16	●	●	25	23	250	17	≥32				AATN-2-0002	APM-14			
S32T MT-NR/L 16	●	●	32	30	300	22	≥40					APM-01			
S40U MT-NR/L 16	●	●	40	37.5	350	27	≥50	TNM. 2204..	AMK-04	AKV-02-M6x22	AATN-3-0015	APM-02			
S32T MT-NR/L 22	●	●	32	30	300	22	≥40								
S40U MT-NR/L 22	●	●	40	37.5	350	27	≥50								
S50U MT-NR/L 22	●	○	50	47	350	35	≥63								

R: Sağ/Right L: Sol/Left ● Stokta/In Stock ○ Stokta Yok/Non Stock Item

Sipariş Örneği/Ordering Example : 1 ad./pcs. S20R MTFNR 16

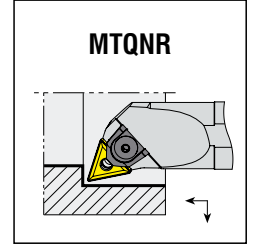
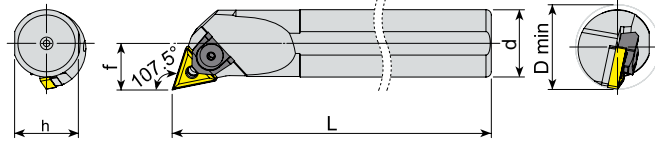

Takım Kodu Ordering Code	Stok Stock		Takım Ölçüleri (mm) Dimension (mm)					Kesici Uç Insert	Yedek Parçaları Spare Parts						
	R	L	d	h	L	f	D min		Baskı Pabucu Wedge Clamp	Pabuç Vidası Clamp Screw	Aitlik Shim	Pim Pin	Pul Stamp	Anahtar Allen Key	
S20R MTQNR/L 16	●	●	20	18.3	200	13	≥25	TNM. 1604..	AMK-02	AKV-17-M5x15	-	APM-11	-	ABPL-01	AAL-03-3
S25S MTQNR/L 16	●	●	25	23	250	17	≥32				AATN-2-0002	APM-14			
S32T MTQNR/L 16	●	●	32	30	300	22	≥40					APM-01			
S40U MTQNR/L 16	●	●	40	37.5	350	27	≥50		AMK-04	AKV-02-M6x22					
S32T MTQNR/L 22	●	●	32	30	300	22	≥40	TNM. 2204..			AATN-3-0015	APM-02			
S40U MTQNR/L 22	●	●	40	37.5	350	27	≥50								
S50V MTQNR/L 22	●	●	50	47	400	35	≥63								

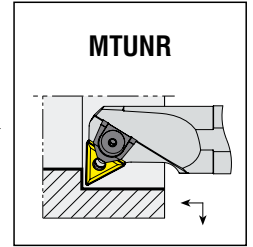
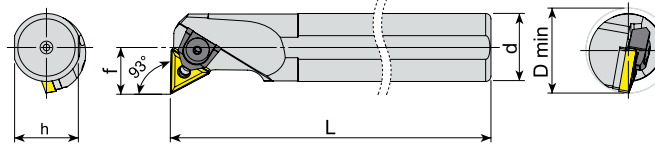

Takım Kodu Ordering Code	Stok Stock		Takım Ölçüleri (mm) Dimension (mm)					Kesici Uç Insert	Yedek Parçaları Spare Parts						
	R	L	d	h	L	f	D min		Baskı Pabucu Wedge Clamp	Pabuç Vidası Clamp Screw	Aitlik Shim	Pim Pin	Pul Stamp	Anahtar Allen Key	
S20R MTUNR/L 16	●	●	20	18.3	200	13	≥25	TNM. 1604..	AMK-02	AKV-17-M5x15	-	APM-03	-	ABPL-01	AAL-03-3
S25S MTUNR/L 16	●	●	25	23	250	17	≥32				AATN-2-0002	APM-14			
S32T MTUNR/L 16	●	●	32	30	300	22	≥40					APM-01			
S40U MTUNR/L 16	●	●	40	37.5	350	27	≥50		AMK-04	AKV-02-M6x22					
S50V MTUNR/L 16	●	○	50	47	400	35	≥63	TNM. 2204..			AATN-3-0015	APM-02			
S32T MTUNR/L 22	●	●	32	30	300	22	≥40								
S40U MTUNR/L 22	●	●	40	37.5	350	27	≥50								
S50V MTUNR/L 22	●	●	50	47	400	35	≥63								

R: Sağ/Right L: Sol/Left ● Stokta/In Stock ○ Stokta Yok/Non Stock Item

Sipariş Örneği/Ordering Example : 1 ad./pcs. S20R MTQNR 16

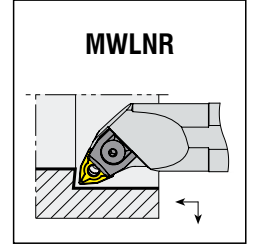
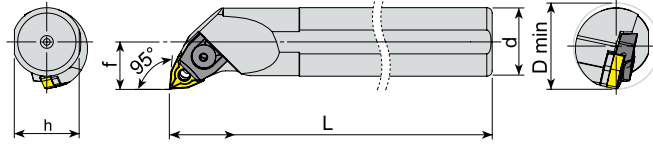

Takım Kodu Ordering Code	Stok Stock		Takım Ölçüleri (mm) Dimension (mm)					Kesici Uç Insert	Yedek Parçaları Spare Parts					
	R	L	d	h	L	f	D min		Baskı Pabucu Wedge Clamp	Pabuç Vidası Clamp Screw	Altlık Shim	Pim Pin	Pul Stamp	Anahtar Allen Key
S16P MWLNR/L 06	●	●	16	14.8	170	11	≥20	WNM. 0604..	AMK-01	AKV-17-M5x15	-	APM-09	-	AAL-03-3
S20R MWLNR/L 06	●	●	20	18.3	200	13	≥25			AKV-04-M5x17		APM-10		
S25S MWLNR/L 06	●	●	25	23	250	17	≥32			AKV-20-M6x19		APM-08		
S25S MWLNR/L 08	●	●	25	23	250	17	≥32	WNM. 0804..	AMK-05	AAWN-3-0001	APM-02	ABPL-01	AAL-03-3	
S32T MWLNR/L 08	●	●	32	30	300	22	≥40							
S40U MWLNR/L 08	●	●	40	37.5	350	27	≥50							

R: Sağ/Right L: Sol/Left ● Stokta/In Stock ○ Stokta Yok/Non Stock Item

Sipariş Örneği/Ordering Example : 1 ad./pcs. S16P MWLNR 06





*konusulan
the spoken kalite...
quality...*

P-SİSTEM

P-SİSTEM DELİK TORNA KATERLERİ
P-SYSTEM BORING BARS



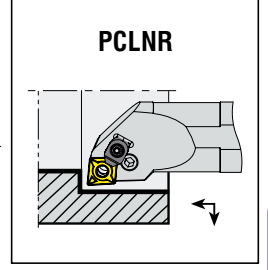
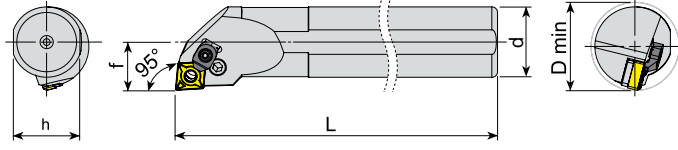

Takım Kodu Ordering Code	Stok Stock		Takım Ölçüleri (mm) Dimension (mm)				Kesici Uç Insert	Yedek Parçaları Spare Parts								
	R	L	d	h	L	f		D min	Levyeye Lever	Levyeye Vidası Lever Screw	Altılık Shim	Altılık Yayı Shim Spring	Baskı Parçası Wedge Clamp	Baskı Vidası Clamp Screw	Anahtar Allen Key	
S16P PCLNR/L 09	●	●	16	14.8	170	11	≥20	CNM. 0903..	APL-07	ALV-07-M6x13	-	-	-	-	-	-
S20R PCLNR/L 09	●	●	20	18.3	200	13	≥25		APL-01	ALV-01-M6x14	AACN-2-0002	AAY-01	-	-	-	-
S25S PCLNR/L 09	○	○	25	23	250	17	≥32	CNM. 1204..	APL-02	ALV-08-M8x16	AACN-3-0001	AAY-02	ACK-05	1515-M4x11	AAL-03-3	
S25S PCLNR/L 12C	●	●	25	23	250	17	≥32			ALV-03-M8x19						
S32T PCLNR/L 12C	●	●	32	30	300	22	≥40	CNM. 1606..	APL-04	ALV-04-M8x22	AACN-3-0002	AAY-03	ACK-09	AAV-05-M6x15	AAL-05-4	
S40U PCLNR/L 12C	●	●	40	37.5	350	27	≥50									
S50V PCLNR/L 12C	●	●	50	47	400	35	≥63	CNM. 1906..	APL-05	ALV-05-M10x27	AACN-3-0003	AAY-04	ACK-09	AAV-05-M6x15	AAL-05-4	
S32T PCLNR/L 16C	●	●	32	30	300	22	≥40									
S40U PCLNR/L 16C	●	●	40	37.5	350	27	≥50	CNM. 1204..	APL-02	ALV-03-M8x19	AACN-3-0001	AAY-02	ACK-05	1515-M4x11	AAL-03-3	
S50V PCLNR/L 16C	●	●	50	47	400	35	≥63									
S40U PCLNR/L 19C	●	●	40	37.5	350	27	≥50	CNM. 1606..	APL-04	ALV-04-M8x22	AACN-3-0002	AAY-03	ACK-09	AAV-05-M6x15	AAL-05-4	
S50V PCLNR/L 19C	●	●	50	47	400	35	≥63									
A25R PCLNR/L 12C	●	●	25	23	200	17	≥32	CNM. 1204..	APL-02	ALV-03-M8x19	AACN-3-0001	AAY-02	ACK-05	1515-M4x11	AAL-03-3	
A32S PCLNR/L 12C	●	●	32	30	250	22	≥40									
A40T PCLNR/L 12C	●	●	40	37.5	300	27	≥50	CNM. 1606..	APL-04	ALV-04-M8x22	AACN-3-0002	AAY-03	ACK-09	AAV-05-M6x15	AAL-05-4	
A50U PCLNR/L 12C	●	●	50	47	350	35	≥63									
A32S PCLNR/L 16C	●	●	32	30	250	22	≥40	CNM. 1906..	APL-05	ALV-05-M10x27	AACN-3-0003	AAY-04	ACK-09	AAV-05-M6x15	AAL-05-4	
A40T PCLNR/L 16C	●	●	40	37.5	300	27	≥50									
A50U PCLNR/L 16C	●	●	50	47	350	35	≥63	CNM. 1906..	APL-05	ALV-05-M10x27	AACN-3-0003	AAY-04	ACK-09	AAV-05-M6x15	AAL-05-4	
A40T PCLNR/L 19C	●	○	40	37.5	300	27	≥50									
A50U PCLNR/L 19C	●	●	50	47	350	35	≥63									

R: Sağ/Right L: Sol/Left ● Stokta/In Stock ○ Stokta Yok/Non Stock Item

Sipariş Örneği/Ordering Example : 1 ad./pcs. S16P PCLNR 09

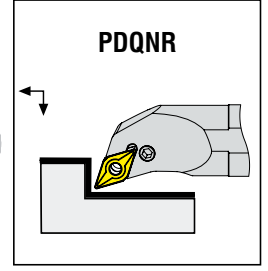
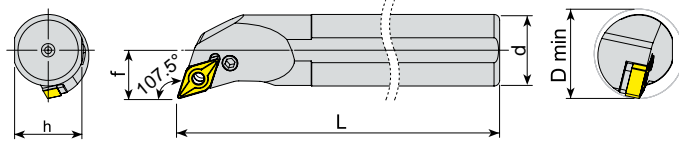

Takım Kodu Ordering Code	Stok Stock		Takım Ölçüleri (mm) Dimension (mm)					Kesici Uç Insert	Yedek Parçaları Spare Parts						
	R	L	d	h	L	f	D min		Levye Lever	Levye Vidası Lever Screw	Altık Shim	Altık Yayı Shim Spring	Baskı Parçası Wedge Clamp	Baskı Vidası Clamp Screw	Anahtar Allen Key
									Levye	Levye Vidası	Altık	Altık Yayı	Baskı Parçası	Baskı Vidası	Anahtar
S20R PDQNR/L 11	○	○	20	18.3	200	13	≥25	DNM. 1104..	APL-01	ALV-01-M6x14 ALV-02-M6x17	AADN-SD317	AAY-01			AAL-02-2.5
S25S PDQNR/L 11	●	●	25	23	250	17	≥32								
S32T PDQNR/L 15	●	●	32	30	300	22	≥40	DNM. 1506..	APL-03	ALV-03-M8x19	AADN-3-0001	AAY-02	-	-	AAL-03-3
S40U PDQNR/L 15	●	●	40	37.5	350	27	≥50								
S50V PDQNR/L 15	●	●	50	47	400	35	≥63	DNM. 1504..	APL-03	ALV-03-M8x19	AADN-2-0003	AAY-02	-	-	AAL-03-3
S32T PDQNR/L 1504	●	●	32	30	300	22	≥40								
S40U PDQNR/L 1504	●	●	40	37.5	350	27	≥50	DNM. 1506..	APL-03	ALV-03-M8x19	AADN-3-0001	AAY-02	-	-	AAL-03-3
S50V PDQNR/L 1504	●	●	50	47	400	35	≥63								
A20P PDQNR/L 11	●	●	20	18.3	170	13	≥25	DNM. 1104..	APL-01	ALV-01-M6x14 ALV-02-M6x17	AADN-SD317	AAY-01	-	-	AAL-02-2.5
A25R PDQNR/L 11	●	●	25	23	200	17	≥32								
A32S PDQNR/L 15	●	●	32	30	250	22	≥40	DNM. 1506..	APL-03	ALV-03-M8x19	AADN-3-0001	AAY-02	-	-	AAL-03-3
A40T PDQNR/L 15	●	●	40	37.5	300	27	≥50								
A50U PDQNR/L 15	●	●	50	47	350	35	≥63	DNM. 1504..	APL-03	ALV-03-M8x19	AADN-2-0003	AAY-02	-	-	AAL-03-3
A32S PDQNR/L 1504	●	○	32	30	250	22	≥40								
A40T PDQNR/L 1504	●	○	40	37.5	300	27	≥50								

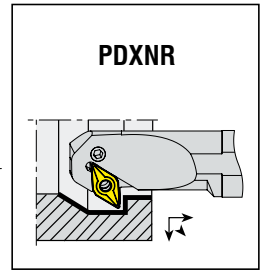
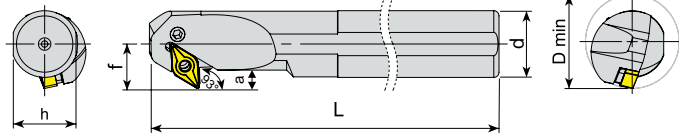

Takım Kodu Ordering Code	Stok Stock		Takım Ölçüleri (mm) Dimension (mm)					Kesici Uç Insert	Yedek Parçaları Spare Parts							
	R	L	d	h	L	f	a		D min	Levye Lever	Levye Vidası Lever Screw	Altık Shim	Altık Yayı Shim Spring	Baskı Parçası Wedge Clamp	Baskı Vidası Clamp Screw	Anahtar Allen Key
										Levye	Levye Vidası	Altık	Altık Yayı	Baskı Parçası	Baskı Vidası	Anahtar
S32T PDXNR/L 15	●	●	32	30	300	25	12	≥45	DNM. 150608	APL-03	ALV-08-M8x16 ALV-03-M8x19	AADN-3-0001	AAY-02	-	-	AAL-03-3
S40U PDXNR/L 15	●	●	40	37.5	350	27	14	≥50								
S50V PDXNR/L 15	●	●	50	47	400	35	19	≥63								

R: Sağ/Right L: Sol/Left ● Stokta/In Stock ○ Stokta Yok/Non Stock Item

Sipariş Örneği/Ordering Example : 1 ad./pcs. S20R PDQNR 11

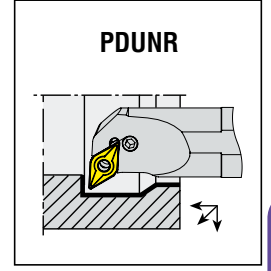
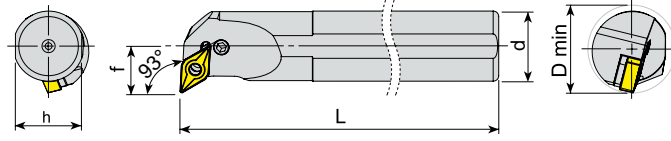

Takım Kodu Ordering Code	Stok Stock		Takım Ölçüleri (mm) Dimension (mm)					Kesici Uç Insert	Yedek Parçaları Spare Parts						
	R	L	d	h	L	f	D min		Levyeye Lever	Levyeye Vidası Lever Screw	Altılık Shim	Altılık Yayı Shim Spring	Baskı Parçası Wedge Clamp	Baskı Vidası Clamp Screw	Anahtar Allen Key
	●	○	●	○	●	○	●		●	●	●	●	●	●	●
S20R PDUNR/L 11	●	●	20	18.3	200	13	≥25	DNM. 1104..	APL-01	ALV-01-M6x14	AADN-SD317	AAY-01	-	-	AAL-02-2.5
S25S PDUNR/L 11	●	●	25	23	250	17	≥32			ALV-02-M6x17					
S25S PDUNR/L 15	●	●	25	23	250	19	≥32	DNM. 1506..	APL-03	ALV-08-M8x16	AADN-3-0001	AAY-02	-	-	AAL-03-3
S32T PDUNR/L 15	●	●	32	30	300	22	≥40			ALV-03-M8x19					
S40U PDUNR/L 15	●	●	40	37.5	350	27	≥50	DNM. 1104..	APL-01	ALV-01-M6x14	AADN-SD317	AAY-01	-	-	AAL-2-2.5
S50V PDUNR/L 15	●	●	50	47	400	35	≥63			ALV-02-M6x17					
A20P PDUNR/L 11	●	●	20	18.3	170	13	≥25	DNM. 1506..	APL-03	ALV-03-M8x19	AADN-3-0001	AAY-02	-	-	AAL-03-3
A25R PDUNR/L 11	●	●	25	23	200	17	≥32			ALV-01-M6x14					
A32S PDUNR/L 15	●	●	32	30	250	22	≥40	DNM. 1506..	APL-03	ALV-02-M6x17	AADN-3-0001	AAY-02	-	-	AAL-03-3
A40T PDUNR/L 15	●	●	40	37.5	300	27	≥50			ALV-03-M8x19					
A50U PDUNR/L 15	●	●	50	47	350	35	≥63								

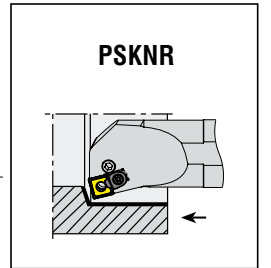
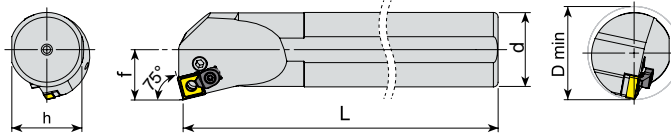

Takım Kodu Ordering Code	Stok Stock		Takım Ölçüleri (mm) Dimension (mm)					Kesici Uç Insert	Yedek Parçaları Spare Parts						
	R	L	d	h	L	f	D min		Levyeye Lever	Levyeye Vidası Lever Screw	Altılık Shim	Altılık Yayı Shim Spring	Baskı Parçası Wedge Clamp	Baskı Vidası Clamp Screw	Anahtar Allen Key
	●	○	●	○	●	○	●		●	●	●	●	●	●	●
S25S PSKNR/L 12C	●	●	25	23	250	17	≥32	SNM. 1204..	APL-02	ALV-08-M8x16	AASN-3-0004	AAY-02	ACK-05	1515-M4x11	AAL-03-3
S32T PSKNR/L 12C	●	●	32	30	300	22	≥40			ALV-03-M8x19					
S40U PSKNR/L 12C	●	●	40	37.5	350	27	≥50								
S50V PSKNR/L 12C	●	●	50	47	400	35	≥63	SNM. 1506..	APL-04	ALV-04-M8x22	AASN-3-0023	AAY-03	-	-	AAL-05-4
S32T PSKNR/L 15	○	○	32	30	300	22	≥40								
S40U PSKNR/L 15	○	○	40	37.5	350	27	≥50								
S50V PSKNR/L 15	○	○	50	47	400	35	≥63								

R: Sağ/Right L: Sol/Left ● Stokta/In Stock ○ Stokta Yok/Non Stock Item

Sipariş Örneği/Ordering Example : 1 ad./pcs. S25S PSKNR 12C

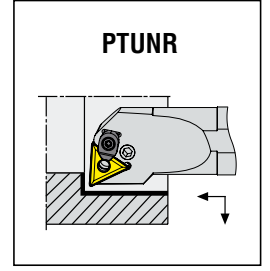
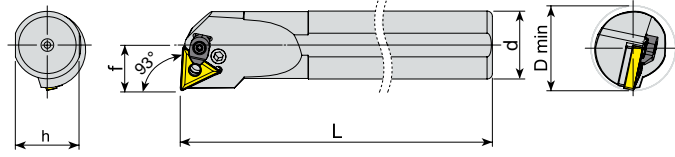

Takım Kodu Ordering Code	Stok Stock		Takım Ölçüleri (mm) Dimension (mm)				Kesici Uç Insert	Yedek Parçaları Spare Parts							
	R	L	d	h	L	f		D min	Levye Lever	Levye Vidası Lever Screw	Altık Shim	Altık Yayı Shim Spring	Baskı Parçası Wedge Clamp	Baskı Vidası Clamp Screw	Anahtar Allen Key
S16P PTUNR/L 16	●	●	16	14.8	170	11	≥20	TNM. 1604..	APL-07	ALV-07-M6x13	-	-	-	-	
S20R PTUNR/L 16	●	●	20	18.3	200	13	≥25			ALV-01-M6x14					
S25S PTUNR/L 16C	●	●	25	23	250	17	≥32		APL-01	ALV-02-M6x17	AATN-3-0025	AAY-01			AAL-02-2.5
S32T PTUNR/L 16C	●	●	32	30	300	22	≥40								
S40U PTUNR/L 16C	●	●	40	37.5	350	27	≥50								
S32T PTUNR/L 22C	●	●	32	30	300	22	≥40	TNM. 2204..	APL-02	ALV-03-M8x19	AATN-3-0015	AAY-02	ACK-05	1515-M4x11	AAL-03-3
S40U PTUNR/L 22C	●	●	40	37.5	350	27	≥50								
S50V PTUNR/L 22C	●	●	50	47	400	35	≥63								



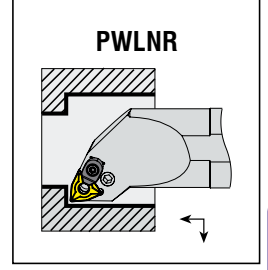
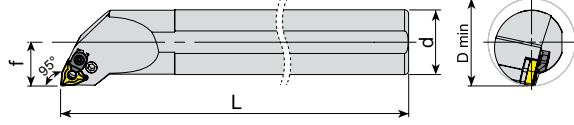
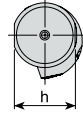

Takım Kodu Ordering Code	Stok Stock		Takım Ölçüleri (mm) Dimension (mm)				Kesici Uç Insert	Yedek Parçaları Spare Parts							
	R	L	d	h	L	f		D min	Levye Lever	Levye Vidası Lever Screw	Altlık Shim	Altlık Yayı Shim Spring	Baskı Parçası Wedge Clamp	Baskı Vidası Clamp Screw	Anahtar Allen Key
S20R PwLNR/L 06	●	●	20	18.3	200	13	≥25	WNM. 0604..	APL-01	ALV-01-M6x14 ALV-02-M6x17	AAWN-SW317	AAY-01	-	-	AAL-02-2.5
S25S PwLNR/L 06	●	●	25	23	250	17	≥32								
S32T PwLNR/L 06	●	●	32	30	300	22	≥40								
S25S PwLNR/L 08C	●	●	25	23	250	17	≥32	WNM. 0804..	APL-02	ALV-03-M8x19	AAWN-3-0001	AAY-02	ACK-05	1515-M4x11	AAL-03-3
S32T PwLNR/L 08C	●	●	32	30	300	22	≥40								
S40U PwLNR/L 08C	●	●	40	37.5	350	27	≥50								
S50V PwLNR/L 08C	●	●	50	47	400	35	≥63	WNM. 0604..	APL-01	ALV-01-M6x14 ALV-02-M6x17	AAWN-SW317	AAY-01	-	-	AAL-02-2.5
A20P PwLNR/L 06	●	●	20	18.3	170	13	≥25								
A25R PwLNR/L 06	●	●	25	23	200	17	≥32								
A32S PwLNR/L 06	●	●	32	30	250	22	≥40	WNM. 0804..	APL-02	ALV-03-M8x19	AAWN-3-0001	AAY-02	ACK-05	1515-M4x11	AAL-03-3
A25R PwLNR/L 08C	●	●	25	23	200	17	≥32								
A32S PwLNR/L 08C	●	●	32	30	250	22	≥40								
A40T PwLNR/L 08C	●	●	40	37.5	300	27	≥50	WNM. 0804..	APL-02	ALV-03-M8x19	AAWN-3-0001	AAY-02	ACK-05	1515-M4x11	AAL-03-3
A50U PwLNR/L 08C	●	●	50	47	350	22	≥63								

R: Sağ/Right L: Sol/Left ● Stokta/In Stock ○ Stokta Yok/Non Stock Item

Sipariş Örneği/Ordering Example : 1 ad./pcs. S20R PwLNR 06





*konusulan
the spoken kalite...
quality...*

S-SİSTEM

S-SİSTEM DELİK TORNA KATERLERİ
S-SYSTEM BORING BARS



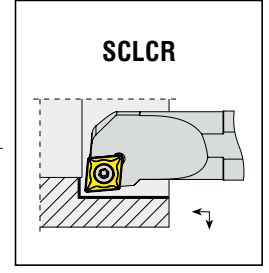
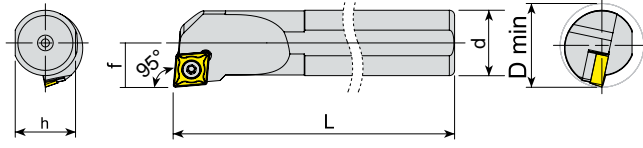

Takım Kodu Ordering Code	Stok Stock		Takım Ölçüleri (mm) Dimension (mm)				Kesici Uç Insert	Yedek Parçaları Spare Parts				
	R	L	d	h	L	f		D min	Sıkma Vidası Screw	Altık Shim	Altık Vidası Shim Screw	Tork Anahtar Torx Key
S0608H SCLCR/L 03	●	○	06	7.3	100	3	≥6	CC.T 030102	3006-M1.6x3.2			80-T06
S0608H SCLCR/L 06	●	●	06	7.3	100	4.5	≥8		4008-M2.5x4.5			
S08H SCLCR/L 06	●	●	08	7.3	100	06	≥11	CC.T 0602..	4008-M2.5x6	-	-	80-T08
S10K SCLCR/L 06	●	●	10	09	125	07	≥13					
S12K SCLCR/L 06	●	●	12	11	125	09	≥16					
S1216P SCLCR/L 06	●	○	12	14.8	170	09	≥16					
S16P SCLCR/L 06	●	●	16	14.8	170	11	≥20	CC.T 09T3..	4015-M3.5x8	-	-	80-T15
S12K SCLCR/L 09	●	●	12	11	125	09	≥16					
S1416P SCLCR/L 09	●	○	14	14.8	170	9.5	≥17					
S16P SCLCR/L 09	●	●	16	14.8	170	11	≥20					
S1620R SCLCR/L 09	●	○	16	18.3	200	11	≥20					
S20R SCLCR/L 09	●	●	20	18.3	200	13	≥25					
S25S SCLCR/L 09	●	●	25	23	250	17	≥32	4015-M3.5x12	AACN-2-0001	AAV-08-M3.5x8	80-T20	
S32T SCLCR/L 09	●	●	32	30	300	22	≥40					
S25S SCLCR/L 12	●	●	25	23	250	17	≥32	CC.T 1204..	4020-M4.5x12	AACN-2-0003	AAV-10-M4.5x8	80-T20
S32T SCLCR/L 12	●	●	32	30	300	22	≥40					
S40U SCLCR/L 12	●	●	40	37.5	350	27	≥50	4020-M4.5x16	AACN-2-0003	AAV-07-M4.5x13	80-T20	
A08H SCLCR/L 06	●	●	08	7.3	100	06	≥11					
A10H SCLCR/L 06	●	●	10	09	100	07	≥13	CC.T 0602..	4008-M2.5x6	-	-	80-T08
A12H SCLCR/L 06	●	●	12	11	100	09	≥16					
A16M SCLCR/L 09	●	●	16	14.8	150	11	≥20	CC.T 09T3..	4015-M3.5x9	-	-	80-T15
A20P SCLCR/L 09	●	●	20	18.3	170	13	≥25					
A25R SCLCR/L 09	●	●	25	23	200	17	≥32					
A32S SCLCR/L 09	●	●	32	30	250	22	≥40					
A25R SCLCR/L 12	●	●	25	23	200	17	≥32					
A25R SCLCR/L 12	●	●	25	23	200	17	≥32					

R: Sağ/Right L: Sol/Left ● Stokta/In Stock ○ Stokta Yok/Non Stock Item

Sipariş Örneği/Ordering Example : 1 ad./pcs. S0608H SCLCR 06

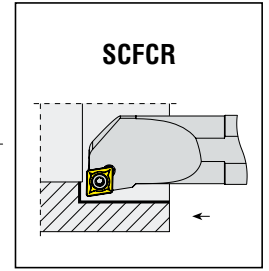
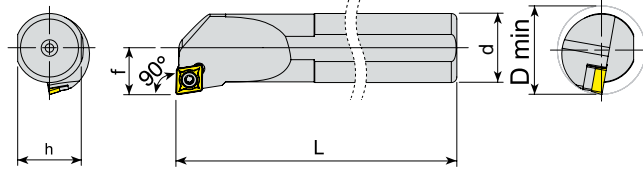

Takım Kodu Ordering Code	Stok Stock		Takım Ölçüleri (mm) Dimension (mm)					Kesici Uç Insert	Yedek Parçaları Spare Parts			
	R	L	d	h	L	f	D min		Sıkma Vidası Screw	Altlık Shim	Altlık Vidası Shim Screw	Tork Anahtar Torx Key
S08H SCFCR/L 06	●	●	08	7.3	100	06	≥11	CC.T 0602..	4008-M2.5x6	-	-	80-T08
S10K SCFCR/L 06	●	●	10	09	125	07	≥13					
S12K SCFCR/L 06	●	●	12	11	125	09	≥16					
S12K SCFCR/L 09	●	●	12	11	125	09	≥16	CC.T 09T3..	4015-M3.5x8	-	-	80-T15
S16P SCFCR/L 09	●	●	16	14.8	170	11	≥20					
S20R SCFCR/L 09	●	●	20	18.3	200	13	≥25					
S25S SCFCR/L 09	●	●	25	23	250	17	≥32	CC.T 1204..	4015-M3.5x12	AACN-2-0001	AAV-08-M3.5x8	80-T20
S25S SCFCR/L 12	○	○	25	23	250	17	≥32					
S32T SCFCR/L 12	○	○	32	30	300	22	≥40					
S40U SCFCR/L 12	○	○	40	37.5	350	27	≥50		1020-M4.5x16		AAV-07-M4.5x13	

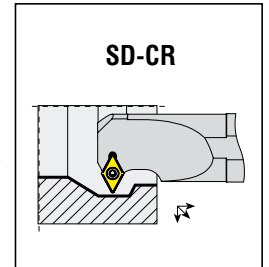
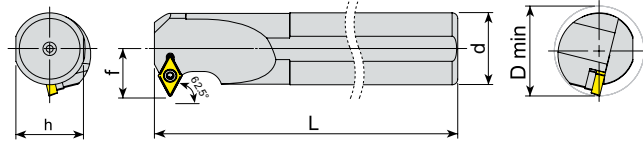

Takım Kodu Ordering Code	Stok Stock		Takım Ölçüleri (mm) Dimension (mm)					Kesici Uç Insert	Yedek Parçaları Spare Parts			
	R	L	d	h	L	f	D min		Sıkma Vidası Screw	Altlık Shim	Altlık Vidası Shim Screw	Tork Anahtar Torx Key
S12K SD-CR/L 07	●	●	12	11	125	09	≥16	DC.T 0702..	4008-M2.5x6	-	-	80-T08
S16P SD-CR/L 07	●	●	16	14.8	170	11	≥20					
S20R SD-CR/L 07	○	○	20	18.3	200	13	≥25					
S16P SD-CR/L 11	●	●	16	14.8	170	11	≥20	DC.T 11T3..	4015-M3.5x11	-	-	80-T15
S20R SD-CR/L 11	●	●	20	18.3	200	13	≥25					
S25S SD-CR/L 11	●	●	25	23	250	17	≥32					
S32T SD-CR/L 11	●	●	32	30	300	22	≥40	4015-M3.5x14	AADN-2-0001	AAV-06-M3.5x11	80-T15	
S40U SD-CR/L 11	●	●	40	37.5	350	27	≥50					

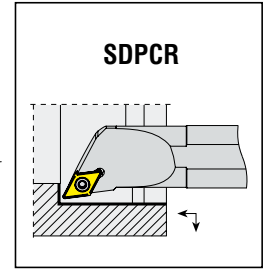
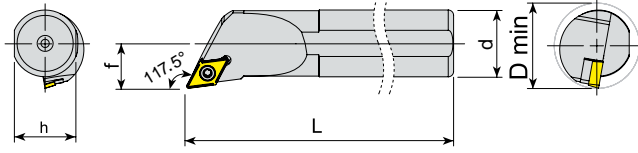

Takım Kodu Ordering Code	Stok Stock		Takım Ölçüleri (mm) Dimension (mm)					Kesici Uç Insert	Yedek Parçaları Spare Parts			
	R	L	d	h	L	f	D min		Sıkma Vidası Screw	Altılık Shim	Altılık Vidası Shim Screw	Tork Anahtar Torx Key
S10K SDPCR/L 07	●	●	10	09	125	07	≥13	DC.T 0702..	4008-M2.5x6	-	-	80-T08
S12K SDPCR/L 07	●	●	12	11	125	09	≥16					
S16P SDPCR/L 11	●	●	16	14.8	170	11	≥20	DC.T 11T3..	4015-M3.5x9	-	-	80-T15
S20R SDPCR/L 11	●	●	20	18.3	200	13	≥25		4015-M3.5x11			
S25S SDPCR/L 11	●	●	25	23	250	17	≥32		4015-M3.5x12			

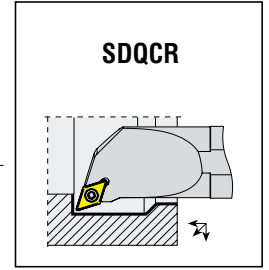
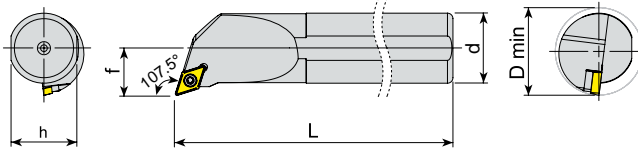

Takım Kodu Ordering Code	Stok Stock		Takım Ölçüleri (mm) Dimension (mm)					Kesici Uç Insert	Yedek Parçaları Spare Parts					
	R	L	d	h	L	f	D min		Sıkma Vidası Screw	Altılık Shim	Altılık Vidası Shim Screw	Tork Anahtar Torx Key		
S10K SDQCR/L 07	●	●	10	09	125	07	≥13	DC.T 0702..	4008-M2.5x6	-	-	80-T08		
S12K SDQCR/L 07	●	●	12	11	125	09	≥16							
S16P SDQCR/L 07	●	●	16	14.8	170	11	≥20							
S20R SDQCR/L 07	●	●	20	18.3	200	13	≥25	DC.T 11T3..	4015-M3.5x9	-	-	80-T15		
S16P SDQCR/L 11	●	●	16	14.8	170	11	≥20		4015-M3.5x11					
S20R SDQCR/L 11	●	●	20	18.3	200	13	≥25		4015-M3.5x12				AAV-08-M3.5x8	
S25S SDQCR/L 11	●	●	25	23	250	17	≥32		4015-M3.5x14				AADN-2-0001	AAV-06-M3.5x11
S32T SDQCR/L 11	●	●	32	30	300	22	≥40							
S40U SDQCR/L 11	●	●	40	37.5	350	27	≥50							
A10H SDQCR/L 07	●	●	10	09	100	07	≥13		DC.T 0702..				4008-M2.5x6	-
A12H SDQCR/L 07	●	●	12	11	100	09	≥16							
A16M SDQCR/L 07	●	●	16	14.8	150	11	≥20							
A20P SDQCR/L 07	●	●	20	18.3	170	13	≥25							
A16M SDQCR/L 11	●	●	16	14.8	150	11	≥20	DC.T 11T3..	4015-M3.5x9	-	-	80-T15		
A20P SDQCR/L 11	●	●	20	18.3	170	13	≥25		4015-M3.5x11					
A25R SDQCR/L 11	●	●	25	23	200	17	≥32		4015-M3.5x12				AAV-08-M3.5x8	
A32S SDQCR/L 11	●	●	32	30	250	22	≥40		4015-M3.5x14				AADN-2-0001	AAV-06-M3.5x11

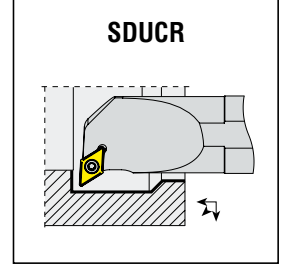
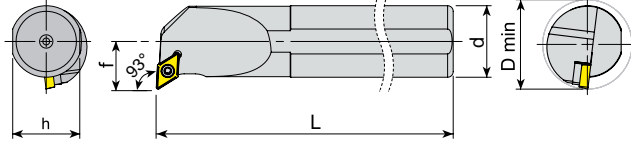

Takım Kodu Ordering Code	Stok Stock		Takım Ölçüleri (mm) Dimension (mm)				Kesici Uç Insert	Yedek Parçaları Spare Parts									
	R	L	d	h	L	f		D min	Sıkma Vidası Screw	Altık Shim	Altık Vidası Shim Screw	Tork Anahtar Torx Key					
S0810K SDUCR/L 07	●	●	08	09	125	06	≥11	DC.T 0702..	4008-M2.5x6	-	-	80-T08					
S10K SDUCR/L 07	●	●	10	09	125	08	≥13										
S12K SDUCR/L 07	●	●	12	11	125	09	≥16										
S1216P SDUCR/L 07	○	●	12	14.8	170	09	≥16										
S1416P SDUCR/L 07	○	●	14	14.8	170	9.5	≥17										
S16P SDUCR/L 07	●	●	16	14.8	170	11	≥20										
S20R SDUCR/L 07	●	●	20	18.3	200	13	≥25	DC.T 11T3..	4015-M3.5x9	-	-	80-T15					
S1416P SDUCR/L 11	○	●	14	14.8	170	9.5	≥17										
S16P SDUCR/L 11	●	●	16	14.8	170	11	≥20										
S1620R SDUCR/L 11	○	●	16	18.3	200	11	≥20										
S20R SDUCR/L 11	●	●	20	18.3	200	13	≥25										
S25S SDUCR/L 11	●	●	25	23	250	17	≥32										
S32T SDUCR/L 11	●	●	32	30	300	22	≥40	DC.T 11T3..	4015-M3.5x14	AADN-2-0001	AAV-06-M3.5x11	80-T15					
S40U SDUCR/L 11	●	●	40	37.5	350	27	≥50										
S50V SDUCR/L 11	○	●	50	47	400	35	≥63										
A0810H SDUCR/L 07	○	●	08	09	100	06	≥11						DC.T 0702..	4008-M2.5x6	-	-	80-T08
A10H SDUCR/L 07	●	●	10	09	100	07	≥13										
A12H SDUCR/L 07	●	●	12	11	100	09	≥16										
A16M SDUCR/L 07	●	●	16	14.8	150	11	≥20										
A20P SDUCR/L 07	●	●	20	18.3	170	13	≥25										
A16M SDUCR/L 11	●	●	16	14.8	150	11	≥20	DC.T 11T3..	4015-M3.5x9	-	-	80-T15					
A20P SDUCR/L 11	●	●	20	18.3	170	13	≥25										
A25R SDUCR/L 11	●	●	25	23	200	17	≥32										
A32S SDUCR/L 11	●	●	32	30	250	22	≥40										

R: Sağ/Right L: Sol/Left ● Stokta/In Stock ○ Stokta Yok/Non Stock Item

Sipariş Örneği/Ordering Example : 1 ad./pcs. S0810K SDUCR 07



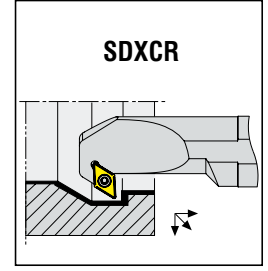
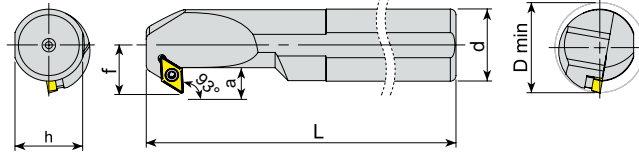

Takım Kodu Ordering Code	Stok Stock		Takım Ölçüleri (mm) Dimension (mm)					Kesici Uç Insert	Yedek Parçaları Spare Parts					
	R	L	d	h	L	f	a		D min	Sıkma Vidası Screw	Altılık Shim	Altılık Vidası Shim Screw	Tork Anahtar Torx Key	
S12K SDXCR/L 07	●	●	12	11	125	09	4	≥17	DC.T 070208			-	-	80-T08
S16P SDXCR/L 07	●	●	16	14.8	170	11	6	≥20						
S20R SDXCR/L 07	○	○	20	18.3	200	13	6	≥25						
S16P SDXCR/L 11	○	○	16	14.8	170	11	6	≥20	DC.T 11T308			-	-	80-T15
S20R SDXCR/L 11	●	●	20	18.3	200	14	7	≥25						
S25S SDXCR/L 11	●	●	25	23	250	17	8.5	≥32						
S32T SDXCR/L 11	●	●	32	30	300	22	12	≥40						
S40U SDXCR/L 11	●	●	40	37.5	350	27	14	≥50	4015-M3.5x14	AADN-2-0001	AAV-08-M3.5x8	AAV-06-M3.5x11		

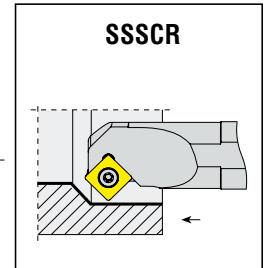
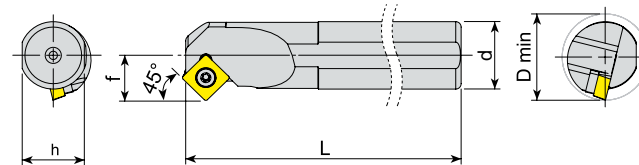

Takım Kodu Ordering Code	Stok Stock		Takım Ölçüleri (mm) Dimension (mm)					Kesici Uç Insert	Yedek Parçaları Spare Parts				
	R	L	d	h	L	f	D min		Sıkma Vidası Screw	Altılık Shim	Altılık Vidası Shim Screw	Tork Anahtar Torx Key	
S16P SSSCR/L 09	●	●	16	14.8	170	11	≥20	SC.T 09T3..			-	-	80-T15
S20R SSSCR/L 09	●	●	20	18.3	200	13	≥25						
S25S SSSCR/L 09	●	●	25	23	250	17	≥32						
S25S SSSCR/L 12	●	○	25	23	250	17	≥32	SC.T 1204..			AASN-2-0004	AAV-10-M4.5x8	80-T20
S32T SSSCR/L 12	●	○	32	30	300	22	≥40						
S40U SSSCR/L 12	●	○	40	37.5	350	27	≥50						

R: Sağ/Right L: Sol/Left ● Stokta/In Stock ○ Stokta Yok/Non Stock Item

Sipariş Örneği/Ordering Example : 1 ad./pcs. S12K SDXCR 07

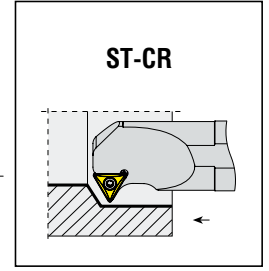
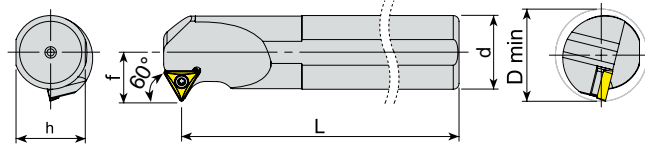

Takım Kodu Ordering Code	Stok Stock		Takım Ölçüleri (mm) Dimension (mm)					Kesici Uç Insert	Yedek Parçaları Spare Parts						
	R	L	d	h	L	f	D min		Sıkma Vidası Screw	Altık Shim	Altık Vidası Shim Screw	Tork Anahtar Torx Key			
S12K ST-CR/L 11	●	○	12	11	125	09	≥17	TC.T 1102..			-	-	80-T08		
S16P ST-CR/L 11	●	○	16	14.8	170	11	≥20								
S20R ST-CR/L 11	○	○	20	18.3	200	13	≥25								
S16P ST-CR/L 16	●	●	16	14.8	170	11	≥20	TC.T 16T3..	4015-M3.5x9		-	AAV-08-M3.5x8	80-T15		
S20R ST-CR/L 16	●	●	20	18.3	200	13	≥25		4015-M3.5x11						
S25S ST-CR/L 16	●	●	25	23	250	17	≥32		4015-M3.5x14					AATN-2-0001	AAV-06-M3.5x11
S32T ST-CR/L 16	●	●	32	30	300	22	≥40								
S40U ST-CR/L 16	●	●	40	37.5	350	27	≥50								

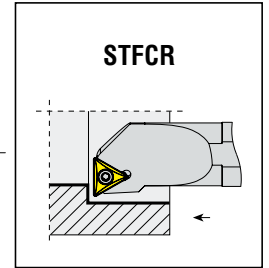
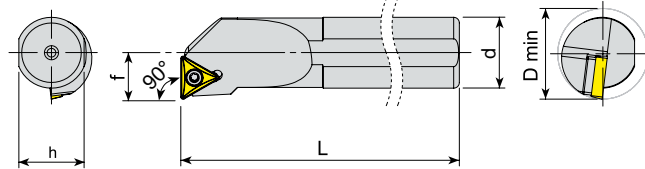

Takım Kodu Ordering Code	Stok Stock		Takım Ölçüleri (mm) Dimension (mm)					Kesici Uç Insert	Yedek Parçaları Spare Parts						
	R	L	d	h	L	f	D min		Sıkma Vidası Screw	Altık Shim	Altık Vidası Shim Screw	Tork Anahtar Torx Key			
S0610F STF CR/L 06	●	●	06	09	80	4.5	≥08	TC.T 06T1..			-	-	80-T06		
S08H STF CR/L 06	●	○	08	7.3	100	06	≥11								
S10K STF CR/L 09	●	●	10	09	125	07	≥13	TC.T 0902..			-	-	80-T07		
S12K STF CR/L 09	●	●	12	11	125	09	≥17								
S12K STF CR/L 11	●	●	12	11	125	09	≥17	TC.T 1102..			-	-	80-T08		
S16P STF CR/L 11	●	●	16	14.8	170	11	≥20								
S20R STF CR/L 11	●	●	20	18.3	200	13	≥25								
S16P STF CR/L 16	●	●	16	14.8	170	11	≥20	TC.T 16T3..	4015-M3.5x9		-	AAV-08-M3.5x8	80-T15		
S20R STF CR/L 16	●	●	20	18.3	200	13	≥25		4015-M3.5x11						
S25S STF CR/L 16	●	●	25	23	250	17	≥32		4015-M3.5x14					AATN-2-0001	AAV-06-M3.5x11
S32T STF CR/L 16	●	●	32	30	300	22	≥40								
S40U STF CR/L 16	○	○	40	37.5	350	27	≥50								

R: Sağ/Right L: Sol/Left ● Stokta/In Stock ○ Stokta Yok/Non Stock Item

Sipariş Örneği/Ordering Example : 1 ad./pcs. S12K ST-CR 11

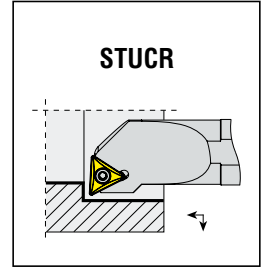
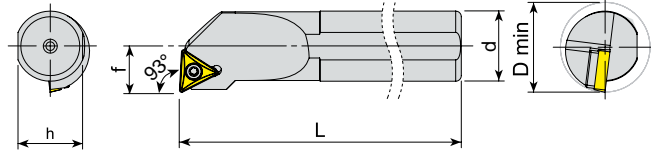

Takım Kodu Ordering Code	Stok Stock		Takım Ölçüleri (mm) Dimension (mm)					Kesici Uç Insert	Yedek Parçaları Spare Parts			
	R	L	d	h	L	f	D min		Sıkma Vidası Screw	Altılık Shim	Altılık Vidası Shim Screw	Tork Anahtar Torx Key
S10K STUCR/L 09	●	●	10	09	125	07	≥13	TC.T 0902..	3007-M2.2x5			80-T07
S12K STUCR/L 09	●	●	12	11	125	09	≥16					
S12K STUCR/L 11	●	●	12	11	125	09	≥17	TC.T 1102..	4008-M2.5x6	-	-	80-T08
S16P STUCR/L 11	●	●	16	14.8	170	11	≥20					
S20R STUCR/L 11	●	●	20	18.3	200	13	≥25	TC.T 16T3..	4015-M3.5x9 4015-M3.5x11 4015-M3.5x14	AATN-2-0001	AAV-08-M3.5x8 AAV-06-M3.5x11	80-T15
S16P STUCR/L 16	●	●	16	14.8	170	11	≥20					
S20R STUCR/L 16	●	●	20	18.3	200	13	≥25					
S25S STUCR/L 16	●	●	25	23	250	17	≥32					
S32T STUCR/L 16	●	●	32	30	300	22	≥40					
S40U STUCR/L 16	●	●	40	37.5	350	27	≥50					

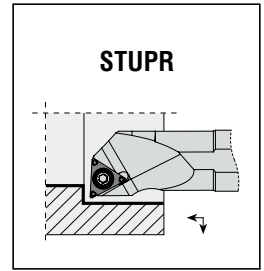
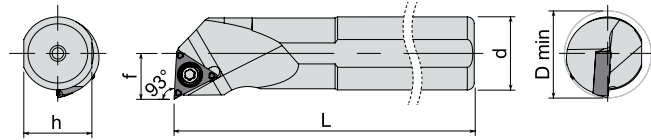

Takım Kodu Ordering Code	Stok Stock		Takım Ölçüleri (mm) Dimension (mm)					Kesici Uç Insert	Yedek Parçaları Spare Parts			
	R	L	d	h	L	f	D min		Sıkma Vidası Screw	Altılık Shim	Altılık Vidası Shim Screw	Tork Anahtar Torx Key
S08H STUPR/L 0802	●	○	08	7.3	100	05	≥10	TP.. 0802..	3006-M2x4			80-T06
S10K STUPR/L 1103	●	○	10	09	125	06	≥12					
S12K STUPR/L 1103	●	○	12	11	125	09	≥16	TP.. 1103..	4010-M3x6 4010-M3x8	-	-	80-T10
S12M STUPR/L 1103	●	○	12	11	150	08	≥16					
S16P STUPR/L 1103	●	○	16	14.8	170	10	≥20					
S16R STUPR/L 1103	●	○	16	14.8	200	10	≥20					

R: Sağ/Right L: Sol/Left ● Stokta/In Stock ○ Stokta Yok/Non Stock Item

Sipariş Örneği/Ordering Example : 1 ad./pcs. S10K STUCR 09

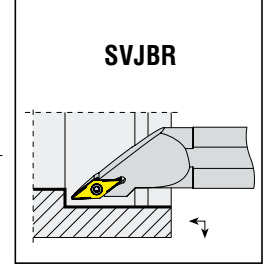
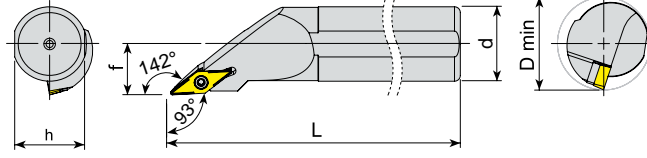

Takım Kodu Ordering Code	Stok Stock		Takım Ölçüleri (mm) Dimension (mm)					Kesici Uç Insert	Yedek Parçaları Spare Parts							
	R	L	d	h	L	f	D min		Sıkma Vidası Screw	Altık Shim	Altık Vidası Shim Screw	Tork Anahtar Torx Key				
S25S SVJBR/L 16	●	●	25	23	250	17	≥32	VBM. 1604..								
S32T SVJBR/L 16	●	●	32	30	300	22	≥40						4015-M3.5x12	AAVN-2-0002	AAV-08-M3.5x8	80-T15
S40U SVJBR/L 16	●	●	40	37.5	350	27	≥50						4015-M3.5x14		AAV-06-M3.5x11	

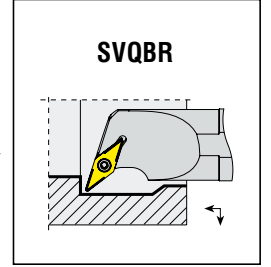
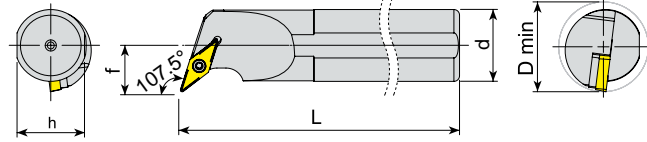

Takım Kodu Ordering Code	Stok Stock		Takım Ölçüleri (mm) Dimension (mm)					Kesici Uç Insert	Yedek Parçaları Spare Parts							
	R	L	d	h	L	f	D min		Sıkma Vidası Screw	Altık Shim	Altık Vidası Shim Screw	Tork Anahtar Torx Key				
S16P SVQBR/L 11	●	●	16	14.8	170	11	≥20	VBM. 1103..								
S20R SVQBR/L 11	●	●	20	18.3	200	13	≥25						4008-M2.5x6	-	-	80-T08
S25S SVQBR/L 16	●	●	25	23	250	17	≥32	VBM. 1604..								
S32T SVQBR/L 16	●	●	32	30	300	22	≥40						4015-M3.5x14	AAVN-2-0002	AAV-08-M3.5x8	80-T15
S40U SVQBR/L 16	●	●	40	37.5	350	27	≥50								AAV-06-M3.5x11	

R: Sağ/Right L: Sol/Left ● Stokta/In Stock ○ Stokta Yok/Non Stock Item

Sipariş Örneği/Ordering Example : 1 ad./pcs. S16P SVQBR 11

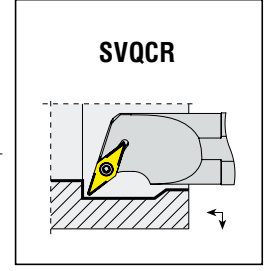
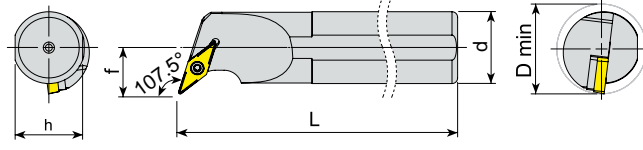

Takım Kodu Ordering Code	Stok Stock		Takım Ölçüleri (mm) Dimension (mm)					Kesici Uç Insert	Yedek Parçaları Spare Parts			
	R	L	d	h	L	f	D min		Sıkma Vidası Screw	Altık Shim	Altık Vidası Shim Screw	Tork Anahtar Torx Key
S16P SVQCR/L 11	●	●	16	14.8	170	11	≥20	VC.T 1103..	4008-M2.5x6	-	-	80-T08
S20R SVQCR/L 11	●	●	20	18.3	200	13	≥25					
S25S SVQCR/L 16	●	●	25	23	250	17	≥32	VC.T 1604..	4015-M3.5x14	AAVN-2-0002	AAV-08-M3.5x8	80-T15
S32T SVQCR/L 16	●	●	32	30	300	22	≥40				AAV-06-M3.5x11	
S40U SVQCR/L 16	●	●	40	37.5	350	27	≥50					

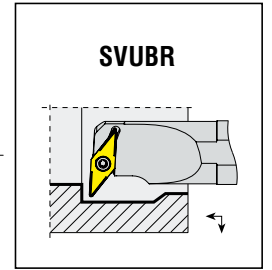
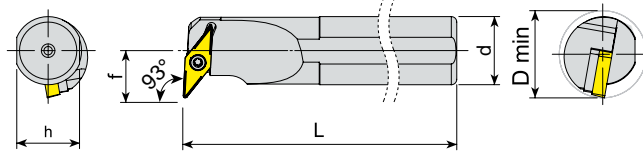

Takım Kodu Ordering Code	Stok Stock		Takım Ölçüleri (mm) Dimension (mm)					Kesici Uç Insert	Yedek Parçaları Spare Parts			
	R	L	d	h	L	f	D min		Sıkma Vidası Screw	Altık Shim	Altık Vidası Shim Screw	Tork Anahtar Torx Key
S16P SVUBR/L 11	●	●	16	14.8	170	12.5	≥20	VBM. 1103..	4008-M2.5x6	-	-	80-T08
S20R SVUBR/L 11	●	●	20	18.3	200	13	≥25					
S25S SVUBR/L 16	●	●	25	23	250	19	≥32	VBM. 1604..	4015-M3.5x14	AAVN-2-0002	AAV-06-M3.5x11	80-T15
S32T SVUBR/L 16	●	●	32	30	300	22	≥40					
S40U SVUBR/L 16	●	●	40	37.5	350	27	≥50					

R: Sağ/Right L: Sol/Left ● Stokta/In Stock ○ Stokta Yok/Non Stock Item

Sipariş Örneği/Ordering Example : 1 ad./pcs. S16P SVUBR 11

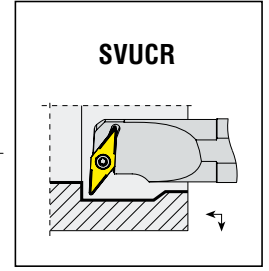
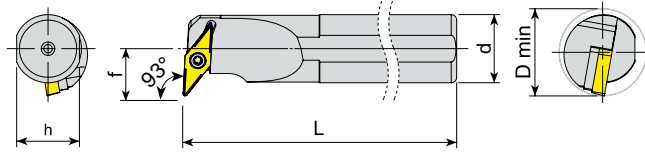

Takım Kodu Ordering Code	Stok Stock		Takım Ölçüleri (mm) Dimension (mm)					Kesici Uç Insert	Yedek Parçaları Spare Parts			
	R	L	d	h	L	f	D min		Sıkma Vidası Screw	Altık Shim	Altık Vidası Shim Screw	Tork Anahtar Torx Key
S16P SVUCR/L 11	●	●	16	14.8	170	12.5	≥20	VC.T 1103..	4008-M2.5x6	-	-	80-T08
S20R SVUCR/L 11	●	●	20	18.3	200	13	≥25					
S25S SVUCR/L 16	●	●	25	23	250	19	≥32	VC.T 1604..	4015-M3.5x14	AAVN-2-0002	AAV-06-M3.5x11	80-T15
S32T SVUCR/L 16	●	●	32	30	300	22	≥40					
S40U SVUCR/L 16	●	●	40	37.5	350	27	≥50					

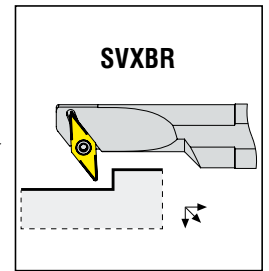
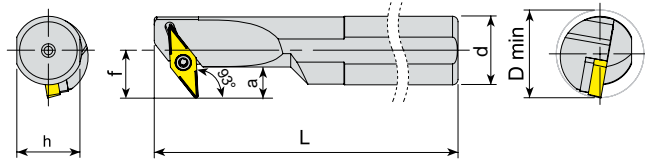

Takım Kodu Ordering Code	Stok Stock		Takım Ölçüleri (mm) Dimension (mm)						Kesici Uç Insert	Yedek Parçaları Spare Parts			
	R	L	d	h	L	f	a	D min		Sıkma Vidası Screw	Altık Shim	Altık Vidası Shim Screw	Tork Anahtar Torx Key
S16P SVXBR/L 11	●	●	16	14.8	170	11	6	≥20	VBM. 1103..	4008-M2.5x6	-	-	80-T08
S20R SVXBR/L 11	●	●	20	18.3	200	13	6	≥25					
S25S SVXBR/L 16	●	●	25	23	250	19	8.5	≥32	VBM. 1604..	4015-M3.5x14	AAVN-2-0002	AAV-06-M3.5x11	80-T15
S32T SVXBR/L 16	●	●	32	30	300	22	12	≥40					
S40U SVXBR/L 16	●	●	40	37.5	350	27	14	≥50					

R: Sağ/Right L: Sol/Left ● Stokta/In Stock ○ Stokta Yok/Non Stock Item

Sipariş Örneği/Ordering Example : 1 ad./pcs. S16P SVXBR 11

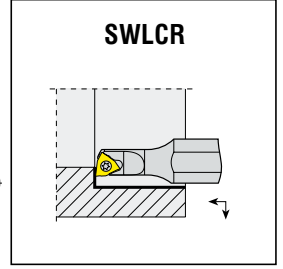
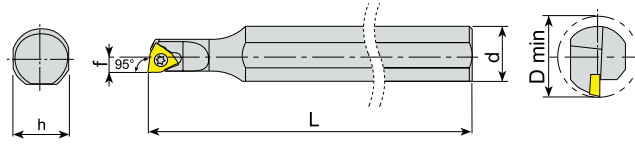

Takım Kodu Ordering Code	Stok Stock	Takım Ölçüleri (mm) Dimension (mm)					Kesici Uç Insert	Yedek Parçaları Spare Parts			
		d	h	L	f	D min		Sıkma Vidası Screw	Altık Shim	Altık Vidası Shim Screw	Tork Anahtar Torx Key
S0608H SWLCR 03	●	08	7.3	100	04	≥08					
S0810K SWLCR 03	●	10	09	125	07	≥10	WC.. 0302..	4008-M2.5x4.5	-	-	80-T08

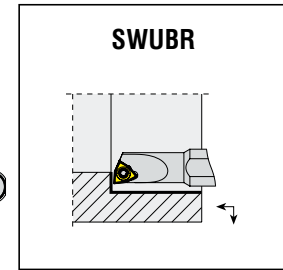
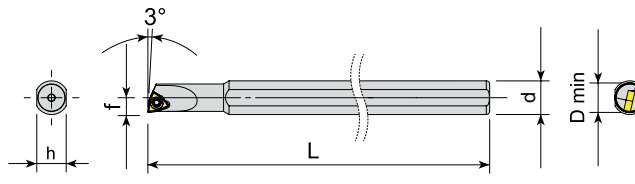

Takım Kodu Ordering Code	Stok Stock	Takım Ölçüleri (mm) Dimension (mm)					Kesici Uç Insert	Yedek Parçaları Spare Parts			
		d	h	L	f	D min		Sıkma Vidası Screw	Altık Shim	Altık Vidası Shim Screw	Tork Anahtar Torx Key
S08H SWUBR 06-5.5	●	08	7.3	100	2.75	≥5.5					
S08H SWUBR 06-7	●	08	7.3	100	3.5	≥7	WBGT 060102	3006-M2x4	-	-	80-T06

R: Sağ/Right L: Sol/Left ● Stokta/In Stock ○ Stokta Yok/Non Stock Item

Sipariş Örneği/Ordering Example : 1 ad./pcs. S0608H SWLCR 03



*konusulan
the spoken kalite...
quality...*

KARTUŞLAR

KARTUŞLAR
CARTRIDGE





S

1

T

2

F

3

C

4

R

5

12

6

C

7

A

8

16

9

1 Sıkma Tipi / Method of Mounting of Insert

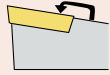

Deliksiz Üstten Sıkma
Top clamping without hole

C

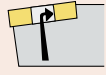

Delikten Laveyle Sıkma
Hole Clamping (Lever Lock)

P

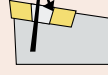

Vida ile Sıkma
Screw on

S

2 Uç Tipi / Insert Shape



C



S



T

3 Yanaşma Açısı / ToolHolder Shape

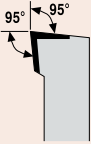

L



S



F

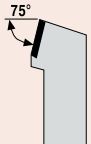

R



K

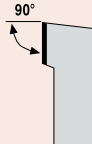

G

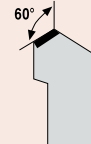

W

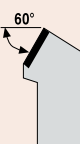

T

4 Serbest Uç Açısı / Clearance angle of Insert



C



P



N

5 Kesme Yönü / Cutting Direction

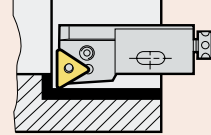

R

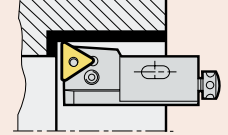

L

6 Kesme Kenar Yüksekliği / Cutting Edge Height

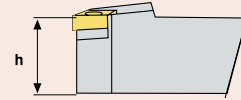

7 Kartuş Kodu / Cartridge Code

C
(Kartuş / Cartridge)

8 Kartuş Tipi / Type of Cartridge

A
(ISO 5611)

9 Kesme Kenar Uzunluğu / Cutting Edge Length

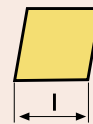

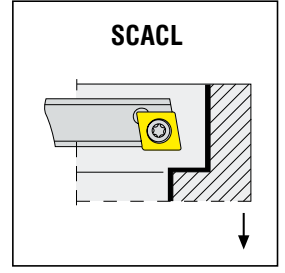
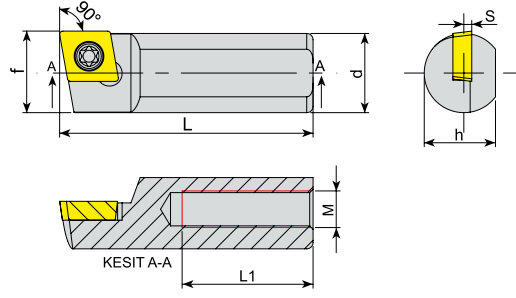

Takım Kodu Ordering Code	Stok Stock		Takım Ölçüleri (mm) Dimension (mm)							Kesici Uç Insert	Yedek Parçaları Spare Parts	
	R	L	d	h	L	L1	S	f	M		Sıkma Vidası Screw	Tork Anahtar Torx Key
S10X SCACR/L 06	●	●	10	9	25	10	1	10.3	M5x0.8	CC.. 0602..	4008-M2.5x6	80-T08
S10A SCACR/L 06	●	●	10	9	32	15	1	10.3	M5x0.8			
S10C SCACR/L 06	●	●	10	9	50	25	1	10.3	M5x0.8			
S12B SCACR/L 06	●	●	12	11	40	25	1	12.3	M5x0.8			
S12D SCACR/L 06	○	●	12	11	60	25	1	12.3	M5x0.8	CC.. 09T3..	4015-M3.5x8	80-T15
S15C SCACR/L 09	○	●	15	14	50	25	2	15.3	M8x1.25			
S15E SCACR/L 09	○	●	15	14	70	45	2	15.3	M8x1.25			
S15D SCACR/L 09	○	●	15	14	60	30	2	15.3	M8x1.25			
S16A SCACR/L 09	●	●	16	15	32	15	2	16.5	M6x1			
S16B SCACR/L 09	●	●	16	15	40	20	2	16.5	M6x1			
S16C SCACR/L 09	○	●	16	15	50	25	2	16.5	M6x1			
S16D SCACR/L 09	●	●	16	15	60	30	2	16.5	M6x1			
S16E SCACR/L 09	○	●	16	15	70	30	2	16.5	M6x1			
S16G SCACR/L 09	●	●	16	15	90	30	2	16.5	M6x1			
S16H SCACR/L 09	○	●	16	15	100	35	4	16.5	M6x1	CC.. 1204..	1020-M5x11	80-T20
S18E SCACR/L 09	○	●	18	17	70	30	2	18.5	M8x1.25			
S20E SCACR/L 09	●	●	20	18.3	70	30	2	20.5	M6x1			
S20H SCACR/L 12	●	●	20	18.3	100	30	2	20.5	M6x1			

R: Sağ/Right L: Sol/Left ● Stokta/In Stock ○ Stokta Yok/Non Stock Item

Sipariş Örneği/Ordering Example : 1 ad./pcs. S10X SCACR 06



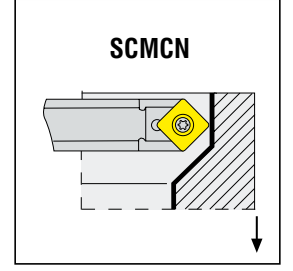
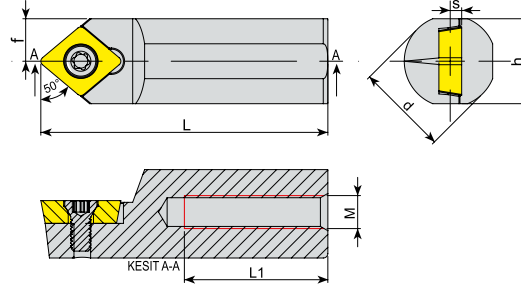

Takım Kodu Ordering Code	Stok Stock	Takım Ölçüleri (mm) Dimension (mm)						Kesici Uç Insert	Yedek Parçaları Spare Parts		
		d	h	L	L1	S	f		M	Sıkma Vidası Screw	Tork Anahtar Torx Key
S10X SCMCN 06	●	10	9	25	10	1	5	M5x0.8			
S16C SCMCN 09	●	16	15	50	25	2	8	M6x1	CC.. 0602..	4008-M2.5x6	80-T08
S16D SCMCN 09	●	16	15	60	25	4	8	M6x1	CC.. 09T3..	4015-M3.5x11	80-T15

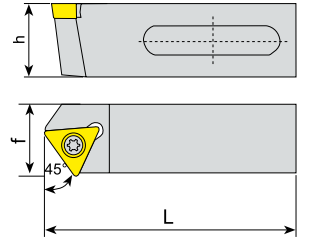

Takım Kodu Ordering Code	Stok Stock		Takım Ölçüleri (mm) Dimension (mm)				Kesici Uç Insert	Yedek Parçaları Spare Parts	
	R	L	d	h	L	f		Sıkma Vidası Screw	Tork Anahtar Torx Key
STXCR/L 2020 B16	○	●	20	20	40	20	TC.. 16T3..		
STXCR/L 2020 E16	○	●	20	20	70	20			
STXCR/L 2020 B16-SA	○	●	20	20	40	20			
STXCR/L 2020 E16-SA	○	●	20	20	70	20			

R: Sağ/Right L: Sol/Left ● Stokta/In Stock ○ Stokta Yok/Non Stock Item

Sipariş Örneği/Ordering Example : 1 ad./pcs. S10X SCMCN 06

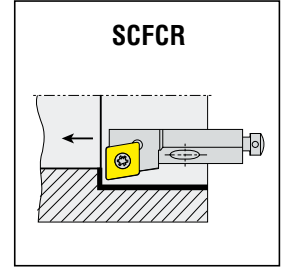
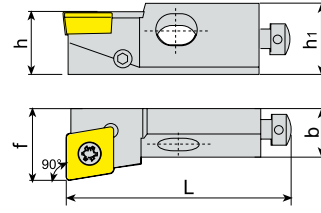
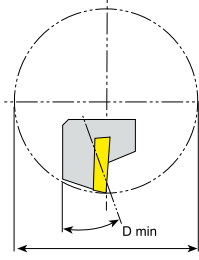

Takım Kodu Ordering Code	Stok Stock		Takım Ölçüleri (mm) Dimension (mm)					Kesici Uç Insert	Yedek Parçaları Spare Parts				
	R	L	h	h1	b	L	f		D min	Altık Shim	Altık Vidası Shim Screw	Sıkma Vidası Screw	Tork Anahtar Torx Key
SCFCR/L 06CA 06	●	●	6	8.5	6	25	8	≥20	CC.T 0602..	-	-	4008-M2.5x6	80-T08
SCFCR/L 08CA 06	●	●	8	11	8	32	10	≥25	CC.T 09T3..	-	-	4015-M3.5x11	80-T15
SCFCR/L 10CA 09	●	●	10	15	11	50	14	≥40	CC.T 1204..	AACN-2-0003	AAV-10-M4.5x8	4020-M4.5x12	80-T20
SCFCR/L 12CA 12	○	○	12	18	15	55	20	≥50					
SCFCR/L 16CA 12	○	○	16	21	20	63	25	≥60					

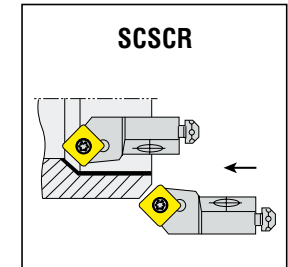
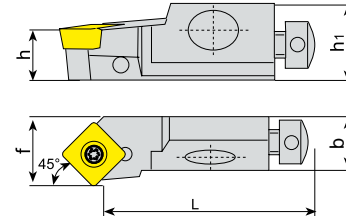
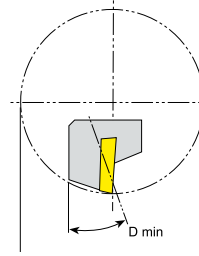

Takım Kodu Ordering Code	Stok Stock		Takım Ölçüleri (mm) Dimension (mm)					Kesici Uç Insert	Yedek Parçaları Spare Parts				
	R	L	h	h1	b	L	f		D min	Altık Shim	Altık Vidası Shim Screw	Sıkma Vidası Screw	Tork Anahtar Torx Key
SCSCR/L 06CA 06	○	○	6	8	6	21	8	≥20	CC.T 0602..	-	-	4008-M2.5x6	80-T08
SCSCR/L 10CA 09	○	○	10	15	11	44	14	≥40	CC.T 09T3..	AACN-2-0001	AAV-06-M3.5x11	4015-M3.5x14	80-T15
SCSCR/L 12CA 12	○	○	12	18	15	47	20	≥50	CC.T 1204..	AACN-2-0003	AAV-07-M4.5x13	1020-M4.5x16	80-T20

R: Sağ/Right L: Sol/Left ● Stokta/In Stock ○ Stokta Yok/Non Stock Item

Sipariş Örneği/Ordering Example : 1 ad./pcs. SCFCR 06CA 06

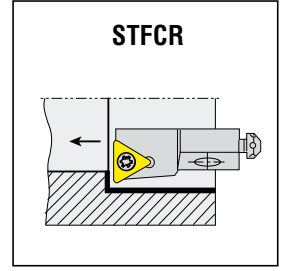
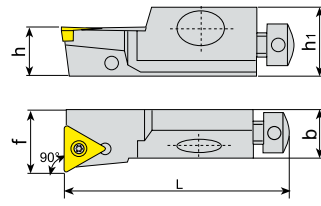
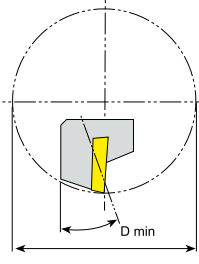

Takım Kodu Ordering Code	Stok Stock		Takım Ölçüleri (mm) Dimension (mm)						Kesici Uç Insert	Yedek Parçaları Spare Parts			
	R	L	h	h1	b	L	f	D min		Altık Shim	Altık Vidası Shim Screw	Sıkma Vidası Screw	Tork Anahtar Torx Key
STFCR/L 08CA 09	●	○	8	11	8	32	10	≥25	TC.T 0902..	-	-	3007-M2.2x5	80-T07
STFCR/L 10CA 11	●	●	10	15	11	50	14	≥40	TC.T 1102..	-	-	4008-M2.5x6	80-T08
STFCR/L 12CA 16	●	○	12	20	15	55	20	≥50	TC.T 16T3..	-	-	4015-M3.5x11	80-T15
STFCR/L 16CA 16	○	○	16	21	20	63	20	≥60		AATN-2-0001	AAV-06-M3.5x11	4015-M3.5x14	

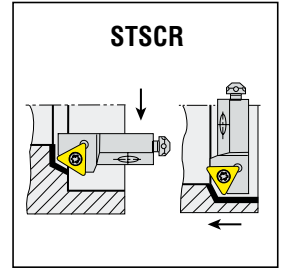
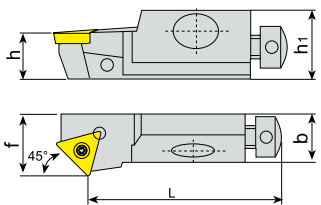
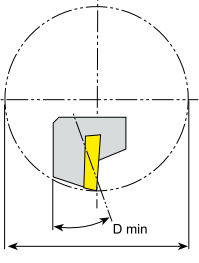

Takım Kodu Ordering Code	Stok Stock		Takım Ölçüleri (mm) Dimension (mm)						Kesici Uç Insert	Yedek Parçaları Spare Parts			
	R	L	h	h1	b	L	f	D min		Altık Shim	Altık Vidası Shim Screw	Sıkma Vidası Screw	Tork Anahtar Torx Key
STSCR/L 08CA 09	●	○	8	11	8	28	10	≥25	TC.T 0902..	-	-	3007-M2.2x5	80-T07
STSCR/L 10CA 11	●	●	10	15	11	44	14	≥40	TC.T 1102..	-	-	4008-M2.5x6	80-T08
STSCR/L 12CA 16	●	○	12	20	15	55	20	≥50	TC.T 16T3..	-	-	4015-M3.5x11	80-T15

R: Sağ/Right L: Sol/Left ● Stokta/In Stock ○ Stokta Yok/Non Stock Item

Sipariş Örneği/Ordering Example : 1 ad./pcs. STFCR 10CA 11

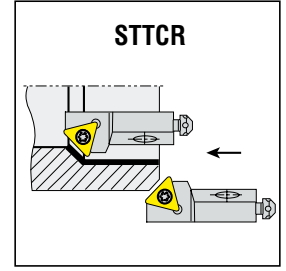
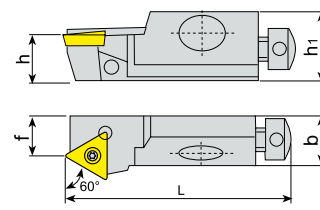
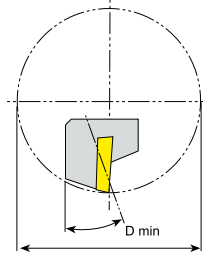

Takım Kodu Ordering Code	Stok Stock		Takım Ölçüleri (mm) Dimension (mm)					Kesici Uç Insert	Yedek Parçaları Spare Parts				
	R	L	h	h1	b	L	f		D min	Altık Shim	Altık Vidası Shim Screw	Sıkma Vidası Screw	Tork Anahtar Torx Key
STTCR/L 08CA 09	●	○	8	11	8	32	6	≥25	TC.T 0902..	-	-	3007-M2.2x5	80-T07
STTCR/L 10CA 11	●	○	10	15	11	50	9	≥40	TC.T 1102..	-	-	4008-M2.5x6	80-T08

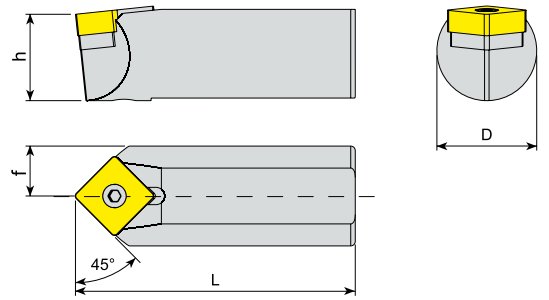

Takım Kodu Ordering Code	Stok Stock	Takım Ölçüleri (mm) Dimension (mm)				Kesici Uç Insert	Yedek Parçaları Spare Parts				
		d	h	L	f		Altık Shim	Sıkma Vidası Clamp Screw	Baskı Parçası Wedge Clamp	Baskı Vidası Clamp Screw	Anahtar Allen Key
S22D PSDNN 12C	●	22	19.5	60	11	SNM. 1204..	AASN-20020	AEV-01-M6x16	ACK-05	1515-M4x11	AAL-02-2.5

R: Sağ/Right L: Sol/Left ● Stokta/In Stock ○ Stokta Yok/Non Stock Item

Sipariş Örneği/Ordering Example : 1 ad./pcs. STTCR 08CA 09



Takım Kodu Ordering Code		Yedek Parçaları Spare Parts				
		Eksenel Ayar Vida Axial Adj. Screw	Radyal Ayar Vida Radial Adj. Screw	Radyal Ayar Vida Anahtarı Radial Adj. Screw Allen Key	Montaj Vida Mounting Screw	Montaj Vida Anahtarı Mounting Screw Allen Key
SCFCR/L SCSCR/L	06CA 06	2600-M4x9.5	2715-M3x5	AAL-09-1.5	AKV-23-M4x10	AAL-03-3
	08CA 06	2600-M4x9.5	2715-M3x5	AAL-09-1.5	AKV-23-M4x10	AAL-03-3
	10CA 09	2600-M5x13	2702-M4X10	AAL-01-2	AKV-02-M6x22	AAL-07-5
	12CA 12	2600-M5x13	2702-M4X10	AAL-01-2	AKV-02-M6x22	AAL-07-5
	16CA 12	2600-M6x18	2725-M5X12	AAL-02-2.5	2506-M8X30	AAL-08-6
STSCR/L	08CA 09	2600-M4x9.5	2715-M3x5	AAL-09-1.5	AKV-23-M4x10	AAL-03-3
STTCR/L	10CA 11	2600-M5x13	2702-M4X10	AAL-01-2	AKV-02-M6x22	AAL-07-5
STFCR/L	12CA 16	2600-M5x13	2702-M4X10	AAL-01-2	AKV-02-M6x22	AAL-07-5
	16CA 16	2600-M6x18	2725-M5X12	AAL-02-2.5	2506-M8X30	AAL-08-6





*konusulan
the spoken kalite...
quality...*

DİŞ AÇMA

DİŞ AÇMA TAKIMLARI
THREADING TOOLHOLDERS





S **E** **R** **25 25** **M** **16** **C**

1 Sıkma Tipi / Method of Mounting of Insert

S: Vida Sıkmalı
S: Screw Clamping
T: Vida Sıkmalı Helis Açılı
T: Screw Clamping with Helix Angle

2 İşlem Tipi / Application

E: Dış / External
I: İç / Internal

3 Kesme Yönü / Cutting Direction

R: Sağ Yan / Right - Hand
L: Sol Yan / Left - Hand

4 Takım Malzemesi / Type of Boring Bar

"A" Yekpare çelik gövde soğutma suyu kanallı / "A" Solid steel with coolant hole
 "E" Çelik başlıkla sert metal gövde ve soğutma suyu kanallı /
 "E" Carbide bar with fixed steel head and coolant hole
 "C" Karbür Şaft / "C" Carbide shank
 "S" Çelik Şaft / "S" Steel shank

4-5 Dış Çap Şaft Ölçüleri / External Shank Size

Şaft : hxb / Shank : hxb
2525 - 25 x 25 mm

5 Şaft Çapı / Shank Diameter

6 Şaft Boyu / Shank Length

A - 32	H - 100	Q - 180	x-special
B - 40	J - 110	R - 200	
C - 50	K - 125	S - 250	
D - 60	L - 140	T - 300	
E - 70	M - 150	U - 350	
F - 80	N - 160	V - 400	
G - 90	P - 170	W - 450	

7 Elmas Ölçüsü / Insert Size

l (mm)	d
06	5/32"
08	3/16"
11	1/4"
16	3/8"
22	1/2"
27	5/8"

8 Baskı Pabucu / Wedge Clamp

S **I** **R** **S** **25** **R** **16** **C**

DIŞ ÇAP DIŞ AÇMA KATERLERİ
EXTERNAL THREADING TOOLHOLDERS

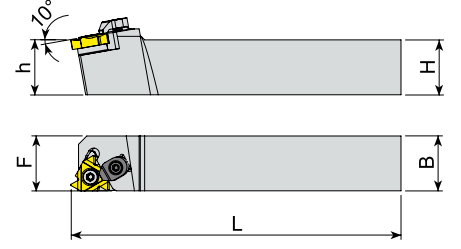
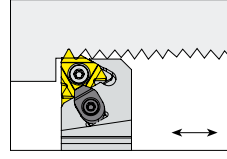

Takım Kodu Ordering Code	Stok Stock		Takım Ölçüleri (mm) Dimension (mm)				Kesici Uç Insert	Yedek Parçaları Spare Parts					
	R	L	h=H	B	L	F		Sıkma Vidası Screw	Altık Shim	Altık Vidası Shim Screw	Baskı Parçası Wedge Clamp	Baskı Vidası Clamp Screw	Tork Anahtar Torx Key
SER/L 0808 E11	●	●	08	08	70	11	11 ER/EL	4008-M2.5x6	-	-	-	-	80-T08
SER/L 1010 E11	●	●	10	10	70	11							
SER/L 1212 F11	●	●	12	12	80	12							
SER/L 1616 H11	●	●	16	16	100	16	16 ER/EL (0.35 - 3) ISO METRIC	4015-M3.5x14	AATN-2-0020	AAV-06-M3.5x11	-	-	80-T15
SER/L 1616 H16C	●	●	16	16	100	16							
SER/L 2020 K16C	●	●	20	20	125	20							
SER/L 2525 M16C	●	●	25	25	150	25	22 ER/EL (3.5 - 4.5) ISO METRIC	1020-M4.5x16	AATN-2-0004	AAV-07-M4.5x13	ACK-05	1515 M4x11	80-T20
SER/L 3232 P16C	●	●	32	32	170	32							
SER/L 2525 M22C	●	●	25	25	150	25							
SER/L 3232 P22C	●	●	32	32	170	32	16 ER/L (1.5-3 TR)	4015-M3.5x14	-	-	-	-	80-T15
SER/L 4040 S22C	●	●	40	40	250	40							
SER/L 2525 M16C-T	●	●	25	25	150	25							
SER/L 2020 K16C-S	●	●	20	20	125	20	22 ER/L (4-6 TR)	1020-M4.5x16	-	-	-	-	80-T20
SER/L 2525 M16C-S	●	●	25	25	150	25							
SER/L 3232 P16C-S	●	●	32	32	170	32							
SER/L 2525 M16C-S	●	●	25	25	150	25	SNDVK 166 ER/L16	4015-M3.5x14	AATN-2-0020	AAV-06-M3.5x11	-	-	80-T15

DIŞ ÇAP DIŞ AÇMA İSVEÇ TİPİ KAYAR OTOMAT MAKİNA KATERLERİ
EXTERNAL THREADING TOOLHOLDERS FOR SWISS TYPE SLIDING AUTOMATIC LATHES

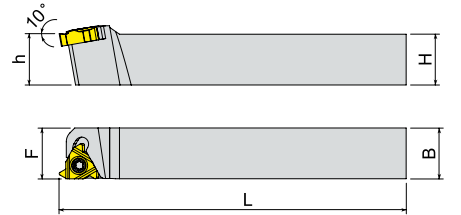
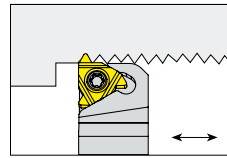

Takım Kodu Ordering Code	Stok Stock		Takım Ölçüleri (mm) Dimension (mm)				Kesici Uç Insert	Yedek Parçaları Spare Parts					
	R	L	h=H	B	L	F		Sıkma Vidası Screw	Altık Shim	Altık Vidası Shim Screw	Baskı Parçası Wedge Clamp	Baskı Vidası Clamp Screw	Tork Anahtar Torx Key
SER/L 1010 K11-S	●	●	10	10	125	10	11 ER/EL	4008-M2.5x6	-	-	-	-	80-T08
SER/L 1212 K11-S	●	●	12	12	125	12							

R: Sağ/Right L: Sol/Left ● Stokta/In Stock ○ Stokta Yok/Non Stock Item / Takımlar standart 1.5° helis açılı olarak üretilir. / The tools have a built in 1.5° helix angle.
UYARI / WARNING : Sayfa 96'daki B ve D figürleri uygulanamaz. / The operation for B and D on page 96 can not be applied.

Sipariş Örneği/Ordering Example : 1 ad./pcs. SER 0808 E11



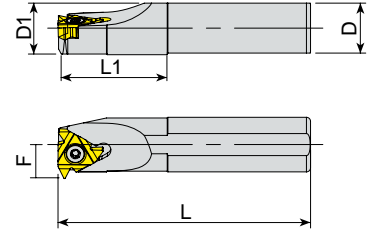
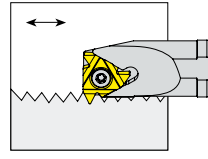

Takım Kodu Ordering Code	Takım Ölçüleri (mm) Dimension (mm)								Kesici Uç Insert	Yedek Parçaları Spare Parts															
	Stok Stock		D	D1	L	L1	F	D min		Sıkma Vidası Screw	Aftlık Shim	Aftlık Vidası Shim Screw	Baskı Parçası Wedge Clamp	Baskı Vidası Clamp Screw	Tork Anahtar Torx Key										
	R	L																							
SIR/L S16X07M 08	●	●	16	07	150	18	5.3	7.8		3007-M2.2x5	-	-	-	-	80-T07										
SIR/L S10H 11	●	●	10	10	100	-	7.4	12		4008-M2.5x6	-	-	-	-	80-T08										
SIR/L S12K 11	●	●	12	12	125	-	8.4	16																	
SIR/L S16X10M 11	●	●	16	10	150	25	7.4	12																	
SIR/L S16X13M 11	●	●	16	13	150	32	8.9	15																	
SIR/L S16M 11	●	●	16	16	150	-	11.7	19																	
SIR/L S16X13M 16	●	●	16	13	150	32	10.2	16		4015-M3.5x9	-	-	-	-	80-T15										
SIR/L S16M 16	●	●	16	16	150	-	11.7	19		4015-M3.5x11															
SIR/L S20X16P 16	●	●	20	16	170	40	11.7	19		4015-M3.5x14						AATN-2-0020	AAV-06-M3.5x11	ACK-05	1515-M4x11						
SIR/L S20P 16	●	●	20	20	170	-	13.7	24																	
SIR/L S25R 16C	●	●	25	25	200	-	16.2	29		ISO METRIC						4015-M3.5x14	AATN-2-0020	AAV-06-M3.5x11	ACK-05	1515-M4x11					
SIR/L S32S 16C	●	●	32	32	250	-	19.7	36													AAV-08-M3.5x8				
SIR/L S40T 16C	●	●	40	40	300	-	23.7	44																	
SIR/L S50U 16C	●	●	50	50	350	-	28.7	54								4020-M4.5x12	-	-	-	-	80-T20				
SIR/L S20P 22	●	●	20	20	170	-	14	24								4020-M4.5x12						AATN-2-0004	AAV-07-M4.5x13	ACK-05	1515-M4x11
SIR/L S25R 22C	●	●	25	25	200	-	18.1	29																	
SIR/L S32S 22C	●	●	32	32	250	-	21.6	38	ISO METRIC		1020-M4.5x16	AATN-2-0004	AAV-07-M4.5x13	ACK-05	1515-M4x11										
SIR/L S40T 22C	●	●	40	40	300	-	25.6	46																	
SIR/L S50U 22C	●	●	50	50	350	-	30.6	58																	
SIR/L S25R 16C-T	●	●	25	25	200	-	16.2	29	16 IR/L (1.5-3 TR)	4015-M3.5x14	-	-	-	-	80-T15										
SIR/L S32S 16C-T	●	●	32	32	250	-	19.7	36	22 IR/L (4-6 TR)	4020-M4.5x12	-	-	-	-	80-T20										
SIR/L S25R 22C-T	●	●	25	25	200	-	18.1	29		1020-M4.5x16															
SIR/L S32S 22C-T	●	●	32	32	250	-	21.6	38																	

R: Sağ/Right L: Sol/Left ● Stokta/In Stock ○ Stokta Yok/Non Stock Item

Takımlar standart 1.5° helis açılı olarak üretilir. / The tools have a built in 1.5° helix angle.

Sipariş Örneği/Ordering Example : 1 ad./pcs. SIR S16X07M 08

UYARI / WARNING

Sayfa 97'deki B ve D figürleri uygulanamaz. / The operation for B and D on page 97 can not be applied.

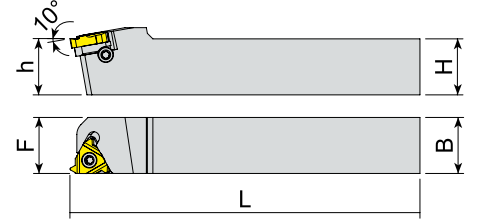
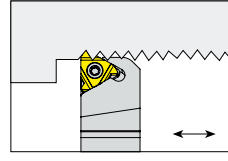

Takım Kodu Ordering Code	Stok Stock		Takım Ölçüleri (mm) Dimension (mm)				Kesici Uç Insert	Yedek Parçaları Spare Parts						
	R	L	h=H	B	L	F		Sıkma Vidası Screw	Sağ Altlık Right Shim	Sol Altlık Left Shim	Altık Vidası Shim Screw	Baskı Parçası Wedge Clamp	Baskı Vidası Clamp Screw	Tork Anahtar Torx Key
TER/L 1616 H16	●	●	16	16	100	16	16 ER/EL							
TER/L 2020 K16	●	●	20	20	125	20								
TER/L 2525 M16	●	●	25	25	150	25								
TER/L 3232 P16	●	●	32	32	170	32								
TER/L 2525 M22	●	●	25	25	150	25	22 ER/EL							
TER/L 3232 P22	●	●	32	32	170	32								
TER/L 4040 S22	●	●	40	40	250	40								
TER/L 2525 M27	●	●	25	25	150	25	27 ER/EL							
TER/L 3232 P27	●	●	32	32	170	32								
TER/L 4040 S27	●	●	40	40	250	40								

R: Sağ/Right L: Sol/Left ● Stokta/In Stock ○ Stokta Yok/Non Stock Item
Takımlar standart 1.5° helis açılı olarak üretilir. / The tools have a built in 1.5° helix angle.

Sipariş Örneği/Ordering Example : 1 ad./pcs. TER 1616 H16

DIŞ ÇAP SAĞ YÖNDE VİDA AÇMA
EXTERNAL RIGHT HAND THREADING OPERATION

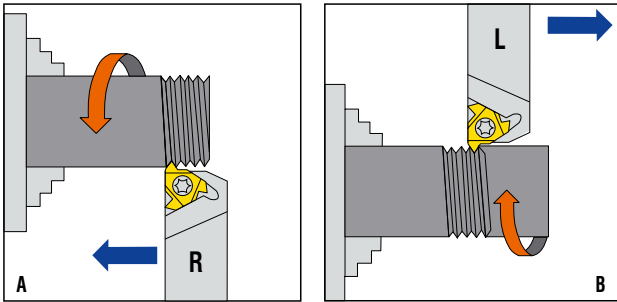

DIŞ ÇAP SOL YÖNDE VİDA AÇMA
EXTERNAL LEFT HAND THREADING OPERATION

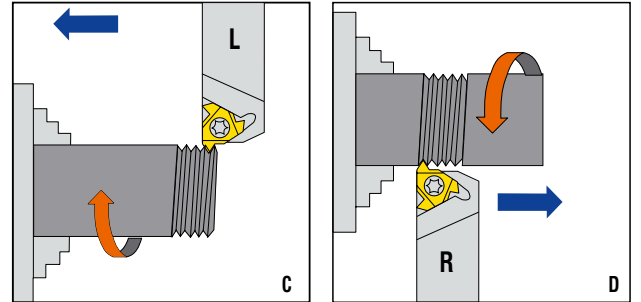

UYARI / WARNING

Figür B ve D için; negatif açılı altık kullanılmalıdır. / For figure B and D; negative shim must be used.
Altıksız katerlerde B ve D figürü uygulanamaz. / B and D figures can not be applied on tools without shim.

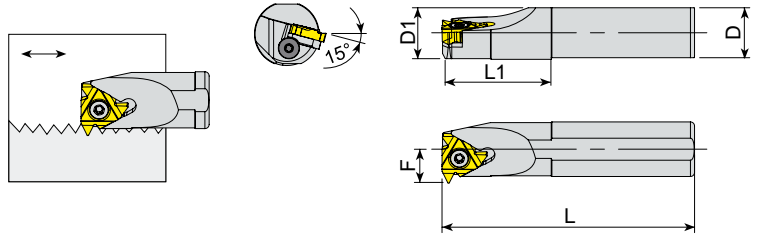

Takım Kodu Ordering Code	Stok Stock		Takım Ölçüleri (mm) Dimension (mm)					Kesici Uç Insert	Yedek Parçaları Spare Parts							
	R	L	D	D1	L	L1	F		D min	Sıkma Vidası Screw	Sol Altlık Left Shim	Sağ Altlık Right Shim	Altılık Vidası Shim Screw	Baskı Parçası Wedge Clamp	Baskı Vidası Clamp Screw	Tork Anahtar Torx Key
	●	○	●	○	●	○	●		○	●	○	●	○	●	○	●
TIR/L S25R 16	●	●	25	25	200	-	16.2	29	16 IR/L	1710-U5-40x12.2	ATS-16E	ATS-16I	AAV-11-U5-40x4.5	-	-	80-T10
TIR/L S32S 16	●	●	32	32	250	-	19.7	36								
TIR/L S40T 16	●	●	40	40	300	-	23.7	44								
TIR/L S50U 16	●	●	50	50	350	-	28.7	54								
TIR/L S25R 22	●	●	25	25	200	-	18.1	29	22 IR/L	1720-U8-32x15	ATS-22E	ATS-22I	AAV-12-U8-32x5.5	-	-	80-T20
TIR/L S32S 22	●	●	32	32	250	-	21.6	38								
TIR/L S40T 22	●	●	40	40	300	-	25.6	46								
TIR/L S50U 22	●	●	50	50	350	-	30.6	58								
TIR/L S32S 27	●	●	32	32	250	-	22.6	40	27 IR/L	1620-M5x18	ATS-27E	ATS-27I	AAV-15-M5x5.7	-	-	80-T20
TIR/L S40T 27	○	○	40	40	300	-	26.6	48		1620-M5x22						
TIR/L S50U 27	○	○	50	50	350	-	31.6	58								

R: Sağ/Right L: Sol/Left ● Stokta/In Stock ○ Stokta Yok/Non Stock Item
Takımlar standart 1.5° helis açılı olarak üretilir. / The tools have a built in 1.5° helix angle.

Sipariş Örneği/Ordering Example : 1 ad./pcs. TIR S25R 16

DELİK İÇİ SAĞ YÖNDE VİDA AÇMA
INTERNAL RIGHT HAND THREADING OPERATION

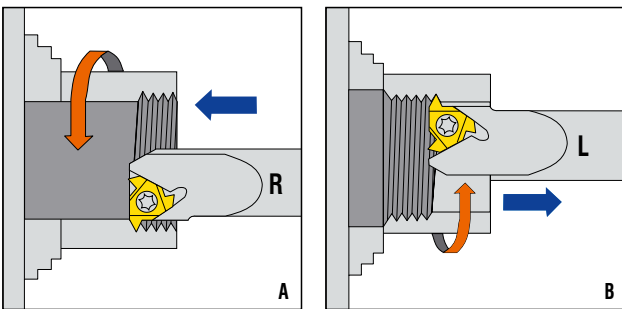

DELİK İÇİ SOL YÖNDE VİDA AÇMA
INTERNAL LEFT HAND THREADING OPERATION

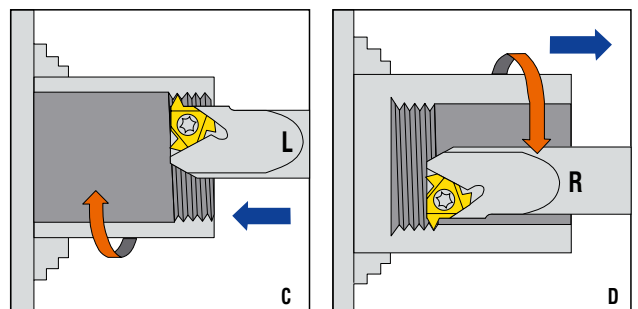

UYARI / WARNING

Figür B ve D için; negatif açılı altlık kullanılmalıdır. / For figure B and D; negative shim must be used.
Altiksiz katerlerde B ve D figürü uygulanamaz. / B and D figures can not be applied on tools without shim.

Diş Helis Açısı Thread Helix Angle

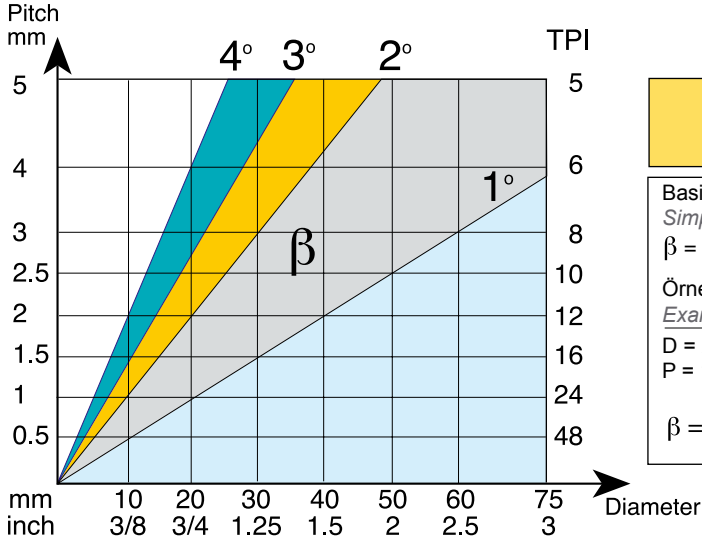

$$\tan \beta = \frac{P}{\pi \times D}$$

Basitleştirilmiş formül
Simplified formula

$$\beta = 20 P/D$$

Örnek :

Example:

$$D = 25 \text{ mm (0.98")}$$

$$P = 1.5 \text{ mm (16 TPI)}$$

$$\beta = \frac{25 \times 1.5}{40} = 1.25^\circ$$

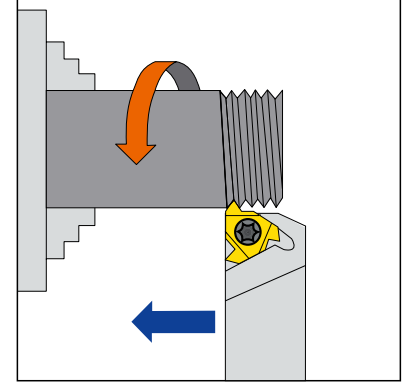

Standart ve Eğik Altıklar Standard and Slanted Shim

Akko diş açma takımlarının, uç yuvaları 1.5° helis açılı olarak üretilir. Farklı helis açılı diş açmak isteyenler altlığı değiştirerek istedikleri dereceyi elde edebilirler.

Negatif helis genellikle sol katerde sağ diş çekmek için kullanılır ya da sağ katerde sol diş çekmek için kullanılır.

Akko Toolholders Pockets have a built in 1.5° helix angle. This angle may be adjusted to better match the thread helix angle by simply changing the shim.

Negative helix is usually used when threading RH thread with LH Holder or LH thread with RH Holder.

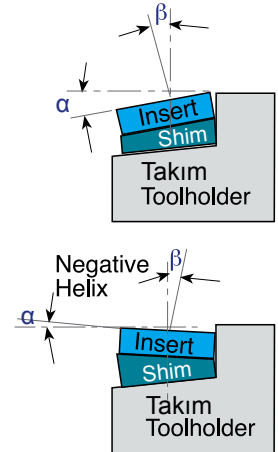

L	IC	Takım Tipi Tool Type	Uç Yuvasının Açısı (α) Pocket's Angle (α)						
			4.5°	3.5°	2.5°	1.5°	0.5°	-0.5°	-1.5°
16	3/8	EX-RH or IN-LH	ATS-16E+4.5	ATS-16E+3.5	ATS-16E+2.5	ATS-16E	ATS-16E+0.5	ATS-16E-0.5	ATS-16E-1.5
16	3/8	EX-RH or IN-LH	ATS-16I+4.5	ATS-16I+3.5	ATS-16I+2.5	ATS-16I	ATS-16I+0.5	ATS-16I-0.5	ATS-16I-1.5
22	1/2	EX-RH or IN-LH	ATS-22E+4.5	ATS-22E+3.5	ATS-22E+2.5	ATS-22E	ATS-22E+0.5	ATS-22E-0.5	ATS-22E-1.5
22	1/2	EX-RH or IN-LH	ATS-22I+4.5	ATS-22I+3.5	ATS-22I+2.5	ATS-22I	ATS-22I+0.5	ATS-22I-0.5	ATS-22I-1.5
27	5/8	EX-RH or IN-LH	ATS-27E+4.5	ATS-27E+3.5	ATS-27E+2.5	ATS-27E	ATS-27E+0.5	ATS-27E-0.5	ATS-27E-1.5
27	5/8	EX-RH or IN-LH	ATS-27I+4.5	ATS-27I+3.5	ATS-27I+2.5	ATS-27I	ATS-27I+0.5	ATS-27I-0.5	ATS-27I-1.5



Altlık Değişirme Öneri Tablosu / Shim Change Recommendation

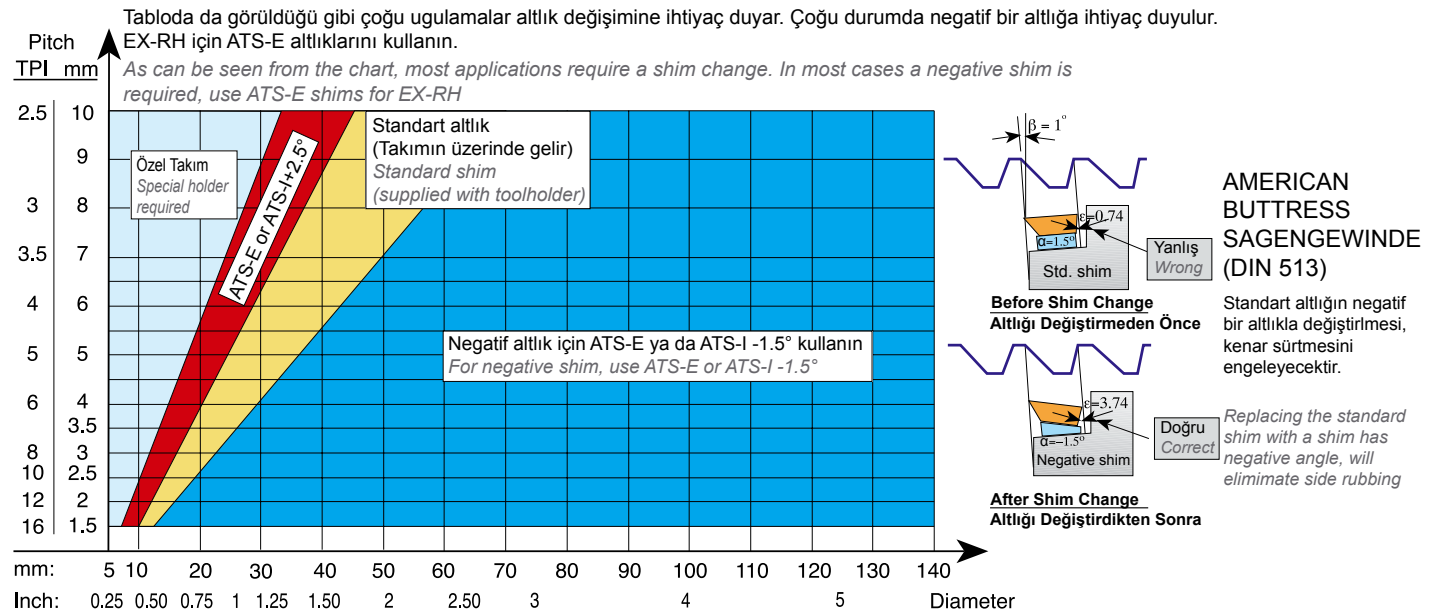
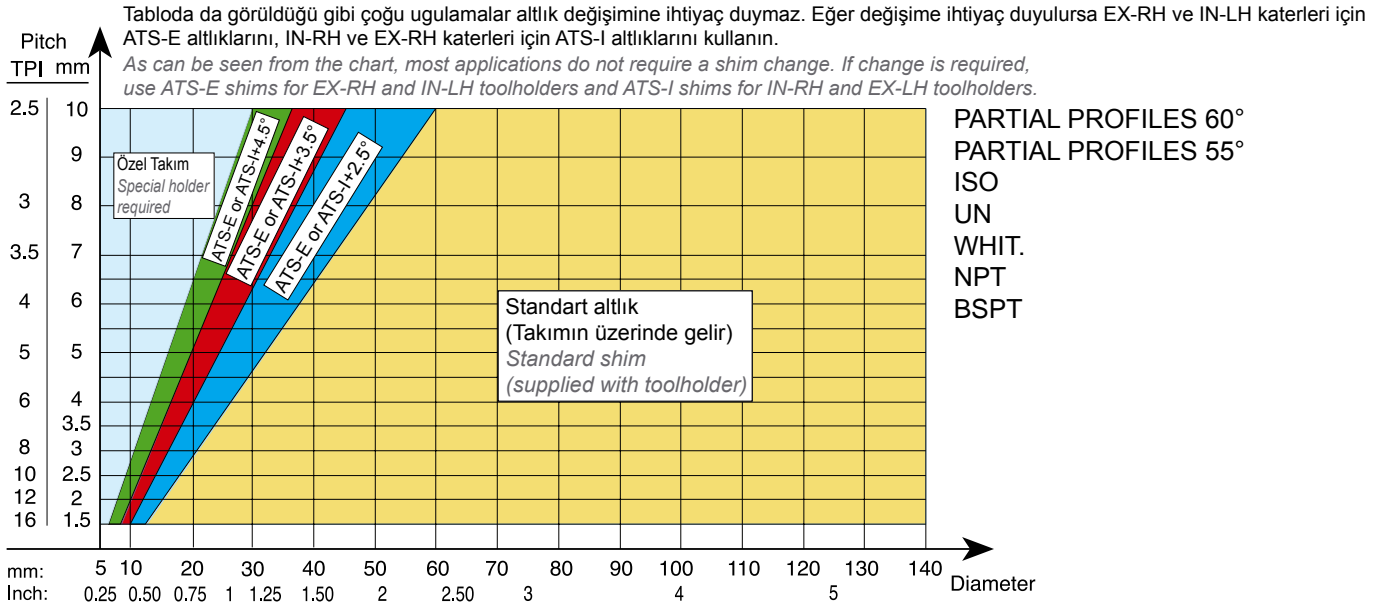
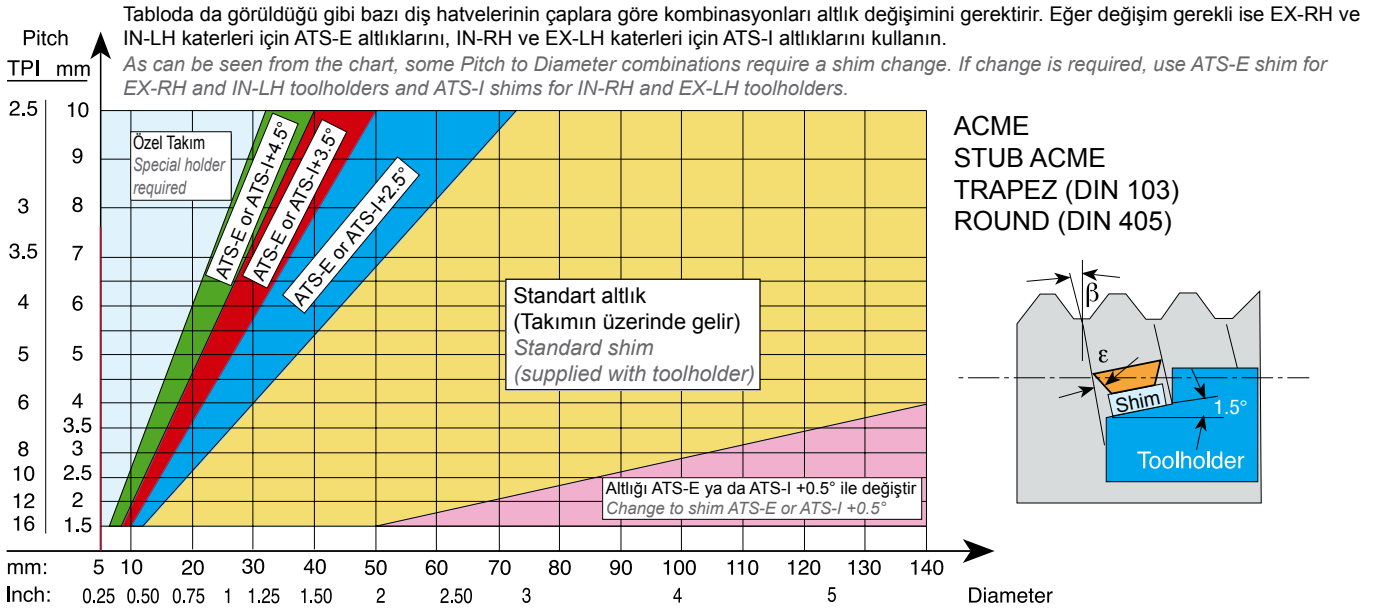



*konusulan
the spoken kalite...
quality...*

KANAL AÇMA

KANAL AÇMA TAKIMLARI
GROOVING TOOLHOLDERS





AKKO **A** **AKT** - **K** - **R** - **2525**

1 2 3 4 5

100 - 150 - **4** - **T22**

6 7 8

2 Kesiş Stili / Cutter Style

DKT : Dış Çap Kanal Açma Takımı - *External Grooving Toolholders*
IKT : Delik İçi Kanal Açma Takımı - *Internal Grooving Toolholders*
AKT : Dış Çap Alın Kanal Açma Takımı - *Face Grooving Toolholders*
LKT : L Tip Alın Kanal Açma Takımları - *L Type Face Grooving Toolholders*

3 Uç Tipi / Insert Type

KRLY / MGM.
HRN / S312, S229, S224, S223
ISCR / DGN, GI, GTN
SNDVK / 123, 151, 154.91
ZCC
KM / A4.
ARN / LOMR.

TGTC / TD.

4 Kesme Yönü / Cutting Direction

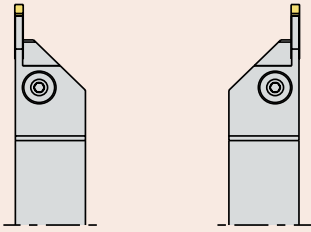

R

L

5 Kesme Kenar Yüksekliği ve Şaft Genişliği Cutting Edge Height and Shank Width

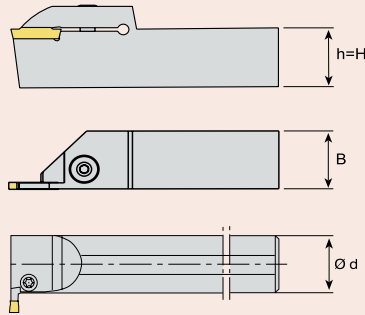

6 Kesme Aralığı / Cutting Diameter

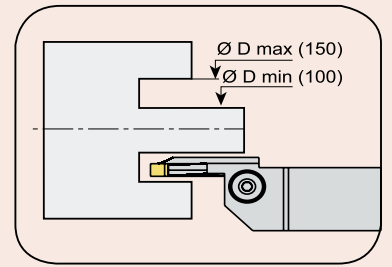

7 Kesme Kenar Genişliği / Cutting Width Edge

ÖR/E.G :
2 = 2.0 mm
3 = 3.0 mm
4 = 4.0 mm
5 = 5.0 mm
6 = 6.0 mm
8 = 8.0 mm

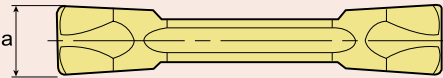

8 Kesme Derinliği / Cutting Depth

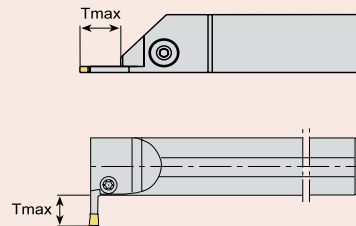

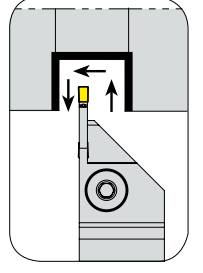
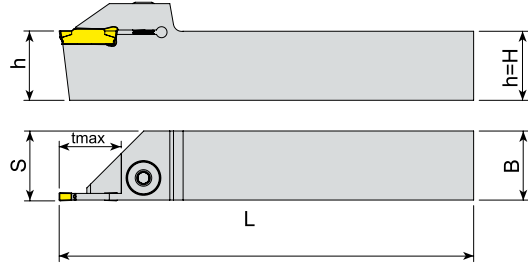

Takım Kodu Ordering Code	Stok Stock		Takım Ölçüleri (mm) Dimension (mm)					Kesici Uç Insert	Yedek Parçaları Spare Parts		
	R	L	h=H	B	L	S	t _{max}		Sıkma Vidası Clamp Screw	Pul Stamp	Anahtar Allen Key
ADKT-K-R/L-1212-2-T15	●	●	12	12	100	12.3	15	MGM. - 2	AKV-02-M6x22	ABPL-01	AAL-03-3
ADKT-K-R/L-1616-2-T15	●	●	16	16	100	16.3	15				
ADKT-K-R/L-2020-2-T15	●	●	20	20	125	20.3	15				
ADKT-K-R/L-2525-2-T15	●	●	25	25	150	25.3	15				
ADKT-K-R/L-3232-2-T15	●	●	32	32	170	32.3	15				
ADKT-K-R/L-1212-3-T15	●	●	12	12	100	12.3	15	MGM. - 3			
ADKT-K-R/L-1616-3-T15	●	●	16	16	100	16.4	15				
ADKT-K-R/L-2020-3-T20	●	●	20	20	125	20.4	20				
ADKT-K-R/L-2525-3-R15	●	○	25	25	150	25.4	15				
ADKT-K-R/L-2525-3-T22	●	●	25	25	150	25.4	22				
ADKT-K-R/L-3232-3-T22	●	●	32	32	170	32.4	22	MGM. - 4	2004-M8x1x20	-	AAL-05-4
ADKT-K-R/L-2020-4-T20	●	●	20	20	125	20.4	20				
ADKT-K-R/L-2525-4-T18	●	●	25	25	150	25.4	18				
ADKT-K-R/L-2525-4-T22	●	●	25	25	150	25.4	22				
ADKT-K-R/L-3232-4-T22	●	●	32	32	170	32.4	22				
ADKT-K-R/L-2020-5-T20	●	●	20	20	125	20.5	20	MGM. - 5			
ADKT-K-R/L-2525-5-T18	●	●	25	25	150	25.5	18				
ADKT-K-R/L-2525-5-T25	●	●	25	25	150	25.5	25				
ADKT-K-R/L-3232-5-T25	●	●	32	32	170	32.5	25	MGM. - 6			
ADKT-K-R/L-2525-6-T25	●	●	25	25	150	25.6	25				
ADKT-K-R/L-3232-6-T25	●	●	32	32	170	32.6	25				
ADKT-K-R/L-3232-8-T32	●	●	32	32	170	32.8	32	MGM. - 8			

R: Sağ/Right L: Sol/Left ● Stokta/In Stock ○ Stokta Yok/Non Stock Item
KRLY - JD Ucuna Uygundur. / Compatiple with KRLY - JD Insert.

Sipariş Örneği/Ordering Example : 1 ad./pcs. ADKT-K-R-1212-2-T15

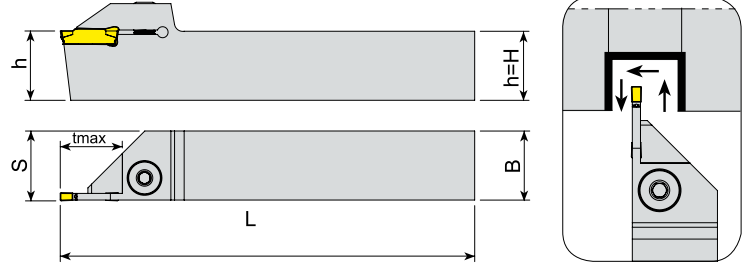

Takım Kodu Ordering Code	Stok Stock		Takım Ölçüleri (mm) Dimension (mm)					Kesici Uç Insert	Yedek Parçaları Spare Parts		
	R	L	h=H	B	L	S	t _{max}		Sıkma Vidası Clamp Screw	Pul Stamp	Anahtar Allen Key
ADKT-KG-R/L-2020-2-T15	●	○	20	20	125	20.2	15	KG.. - 2	AKV-02-M6x22	ABPL-01	AAL-03-3
ADKT-KG-R/L-2525-2-T15	●	○	25	25	150	25.2	15				
ADKT-KG-R/L-1616-3-T20	●	●	16	16	100	16.3	20	KG.. - 3	2004-M8x1x20	-	AAL-05-4
ADKT-KG-R/L-2020-3-T20	●	●	20	20	125	20.3	20				
ADKT-KG-R/L-2525-3-T22	●	●	25	25	150	25.3	22	KG.. - 4	-	-	-
ADKT-KG-R/L-2020-4-T20	●	○	20	20	125	20.4	20				
ADKT-KG-R/L-2525-4-T22	●	○	25	25	150	25.4	22	KG.. - 5	-	-	-
ADKT-KG-R/L-2525-5-T25	○	○	25	25	150	25.5	25				
ADKT-KG-R/L-2525-6-T25	○	○	25	25	150	25.6	25	KG.. - 6	-	-	-

KRLY Ucuna Uygundur. / Compatible with KRLY Insert.

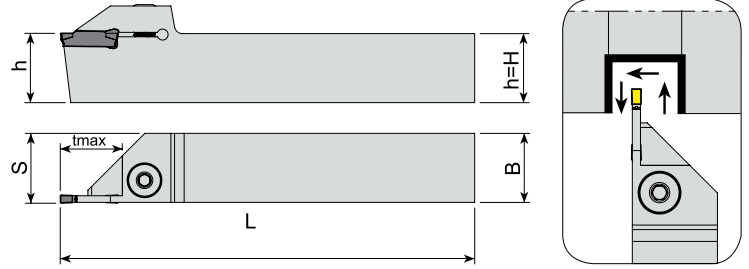

Takım Kodu Ordering Code	Stok Stock		Takım Ölçüleri (mm) Dimension (mm)					Kesici Uç Insert	Yedek Parçaları Spare Parts		
	R	L	h=H	B	L	S	t _{max}		Sıkma Vidası Clamp Screw	Pul Stamp	Anahtar Allen Key
ADKT-SGC-R/L-1212-2-R15	●	○	12	12	100	12.2	15	GCM N20	AKV-02-M6x22	ABPL-01	AAL-03-3
ADKT-SGC-R/L-1616-2-R15	●	○	16	16	100	16.2	15				
ADKT-SGC-R/L-2020-2-R20	●	○	20	20	125	20.2	20	GCM N30	2004-M8x1x20	-	AAL-05-4
ADKT-SGC-R/L-2525-2-R20	●	○	25	25	150	25.2	20				
ADKT-SGC-R/L-1212-3-R15	●	○	12	12	100	12.3	15	GCM N30	-	-	-
ADKT-SGC-R/L-1616-3-R15	●	○	16	16	100	16.3	15				
ADKT-SGC-R/L-2020-3-R22	●	○	20	20	125	20.3	22	GCM N30	-	-	-
ADKT-SGC-R/L-2525-3-R15	●	○	25	25	150	25.3	15				
ADKT-SGC-R/L-2525-3-R22	●	○	25	25	150	25.3	22	-	-	-	-

R: Sağ/Right L: Sol/Left ● Stokta/In Stock ○ Stokta Yok/Non Stock Item
SMTM Ucuna Uygundur. / Compatible with SMTM Insert.

Sipariş Örneği/Ordering Example : 1 ad./pcs. ADKT-KG-R-2020-2-T15

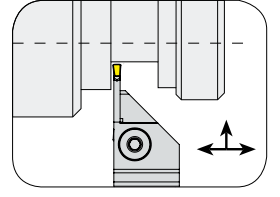
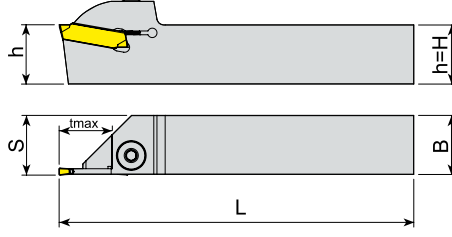

Takım Kodu Ordering Code	Stok Stock		Takım Ölçüleri (mm) Dimension (mm)					Kesici Uç Insert	Yedek Parçaları Spare Parts		
	R	L	h=H	B	L	S	t _{max}		Sıkma Vidası Clamp Screw	Pul Stamp	Anahtar Allen Key
ADKT-H-R/L-2020-3-T20	●	●	20	20	125	20.5	20	S229 - 3	2004-M8x1x20	-	AAL-05-4
ADKT-H-R/L-2525-3-T22	●	●	25	25	150	25.5	22				
ADKT-H-R/L-2020-4-T20	●	●	20	20	125	20.5	20	S229 - 4	2004-M8x1x20	-	AAL-05-4
ADKT-H-R/L-2525-4-T22	●	●	25	25	150	25.5	22				
ADKT-H-R/L-3232-4-T22	●	●	32	32	170	32.5	22	S229 - 5	2004-M8x1x20	-	AAL-05-4
ADKT-H-R/L-2020-5-T20	●	●	20	20	125	20.5	20				
ADKT-H-R/L-2525-5-T25	●	●	25	25	150	25.5	25	S229 - 6	2004-M8x1x20	-	AAL-05-4
ADKT-H-R/L-2525-6-T25	●	●	25	25	150	25.6	25				

HRN Ucuna Uygunudur. / Compatible with HRN Insert.

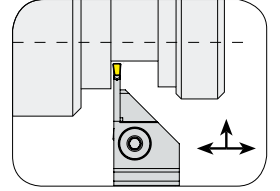
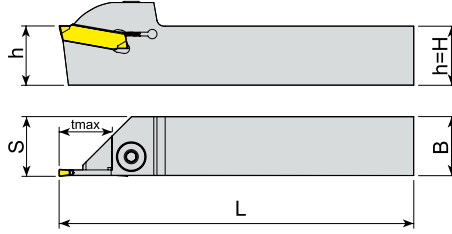

Takım Kodu Ordering Code	Stok Stock		Takım Ölçüleri (mm) Dimension (mm)					Kesici Uç Insert	Yedek Parçaları Spare Parts		
	R	L	h=H	B	L	S	t _{max}		Sıkma Vidası Clamp Screw	Pul Stamp	Anahtar Allen Key
ADKT-HK-R/L-1616-2-T15	●	●	16	16	100	16.3	15	S224 - 2	AKV-02-M6x22	ABPL-01	AAL-03-3
ADKT-HK-R/L-2020-2-T15	●	●	20	20	125	20.3	15				
ADKT-HK-R/L-2525-2-T15	●	●	25	25	150	25.3	15	S224 - 3	2004-M8x1x20	-	AAL-05-4
ADKT-HK-R/L-1616-3-T15	●	●	16	16	100	16.3	15				
ADKT-HK-R/L-2020-3-T20	●	●	20	20	125	20.4	20	S224 - 4	2004-M8x1x20	-	AAL-05-4
ADKT-HK-R/L-2525-3-T22	●	●	25	25	150	25.4	22				
ADKT-HK-R/L-2020-4-T20	●	●	20	20	125	20.4	20	S223 - 2	AKV-02-M6x22	ABPL-01	AAL-03-3
ADKT-HK-R/L-2525-4-T22	●	●	25	25	150	25.4	22				
ADKT-HS223-R/L-2020-2-T15	●	○	20	20	125	20.4	15				

R: Sağ/Right L: Sol/Left ● Stokta/In Stock ○ Stokta Yok/Non Stock Item
HRN Ucuna Uygunudur. / Compatible with HRN Insert.

Sipariş Örneği/Ordering Example : 1 ad./pcs. ADKT-H-R-2020-3-T20

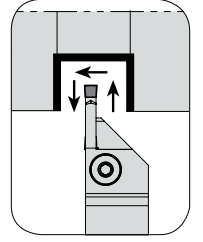
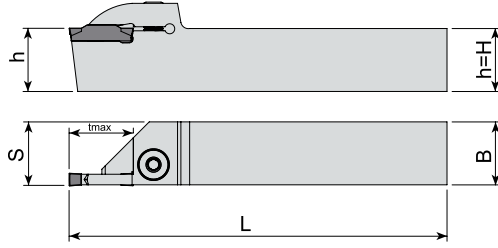

Takım Kodu Ordering Code	Stok Stock		Takım Ölçüleri (mm) Dimension (mm)					Kesici Uç Insert	Yedek Parçaları Spare Parts		
	R	L	h=H	B	L	S	t max		Sıkma Vidası Clamp Screw	Pul Stamp	Anahtar Allen Key
ADKT-ZCC2-R/L-1616-2-T15	●	●	16	16	100	16.3	15	ZT.D - 2	AKV-02-M6x22	ABPL-01	AAL-03-3
ADKT-ZCC2-R/L-2020-2-T15	●	●	20	20	125	20.3	15				
ADKT-ZCC2-R/L-2525-2-T15	●	●	25	25	150	25.3	15				
ADKT-ZCC2-R/L-2525-2.5-T15	●	●	25	25	150	25.3	15	ZT.D - 2.5	2004-M8x1x20	-	AAL-05-4
ADKT-ZCC2-R/L-1616-3-T15	●	●	16	16	100	16.3	15	ZT.D - 3			
ADKT-ZCC2-R/L-2020-3-T12	●	○	20	20	125	20.3	12				
ADKT-ZCC2-R/L-2020-3-T20	●	●	20	20	125	20.3	20				
ADKT-ZCC2-R/L-2525-3-T12	●	○	25	25	150	25.3	12				
ADKT-ZCC2-R/L-2525-3-T22	●	●	25	25	150	25.3	22	ZT.D - 4			
ADKT-ZCC2-R/L-2525-3-R30	●	●	25	25	150	25.3	30				
ADKT-ZCC2-R/L-2020-4-T12	●	○	20	20	125	20.5	12				
ADKT-ZCC2-R/L-2020-4-T20	●	●	20	20	125	20.5	20				
ADKT-ZCC2-R/L-2525-4-T12	●	○	25	25	150	25.5	12	ZT.D - 5			
ADKT-ZCC2-R/L-2525-4-T22	●	●	25	25	150	25.5	22				
ADKT-ZCC2-R/L-2020-5-T12	●	○	20	20	125	20.5	12				
ADKT-ZCC2-R/L-2020-5-T20	●	●	20	20	125	20.5	20				
ADKT-ZCC2-R/L-2525-5-T12	●	○	25	25	150	25.5	12	ZT.D - 6			
ADKT-ZCC2-R/L-2525-5-T25	●	●	25	25	150	25.5	25				
ADKT-ZCC2-R/L-2020-6-T20	●	●	20	20	125	20.6	20				
ADKT-ZCC2-R/L-2525-6-T25	●	●	25	25	150	25.6	25				
ADKT-ZCC2-R/L-3232-6-T25	●	●	32	32	170	32.6	25	ZT.D - 6			
ADKT-ZCC2-R/L-3232-6-T30	●	●	32	32	170	32.6	30				

R: Sağ/Right L: Sol/Left ● Stokta/In Stock ○ Stokta Yok/Non Stock Item
ZCC Ucuna Uygundur. / Compatible with ZCC Insert.

Sipariş Örneği/Ordering Example : 1 ad./pcs. ADKT-ZCC2-R-1616-2-T15

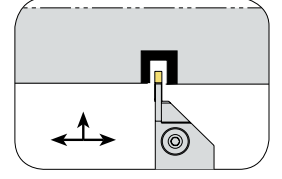
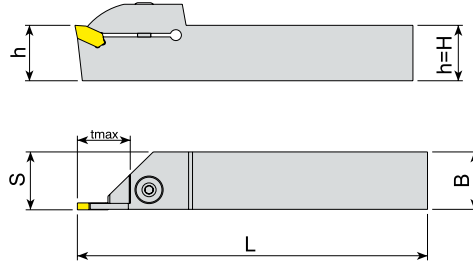

Takım Kodu Ordering Code	Stok Stock		Takım Ölçüleri (mm) Dimension (mm)					Kesici Uç Insert	Yedek Parçaları Spare Parts		
	R	L	h=H	B	L	S	t _{max}		Sıkma Vidası Clamp Screw	Pul Stamp	Anahtar Allen Key
ADKT-ZCC1-R/L-2020-3-T20	●	○	20	20	125	20.3	20	ZQMX - 3	2004-M8x1x20	-	AAL-05-4
ADKT-ZCC1-R/L-2525-3-T22	●	○	25	25	150	25.3	22				
ADKT-ZCC1-R/L-2020-4-T20	●	○	20	20	125	20.4	20	ZQMX - 4	2004-M8x1x20	-	AAL-05-4
ADKT-ZCC1-R/L-2525-4-T22	●	○	25	25	150	25.4	22				

ZCC Ucuna Uygundur. / Compatible with ZCC Insert.

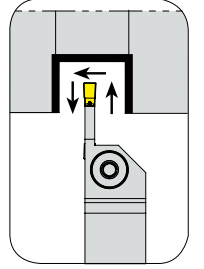
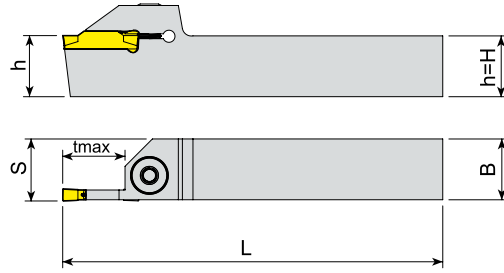

Takım Kodu Ordering Code	Stok Stock		Takım Ölçüleri (mm) Dimension (mm)					Kesici Uç Insert	Yedek Parçaları Spare Parts		
	R	L	h=H	B	L	S	t _{max}		Sıkma Vidası Clamp Screw	Pul Stamp	Anahtar Allen Key
ADKT-123-R/L-1212-1.5-R15	●	○	12	12	100	12.2	15	123 - 1.5	AKV-02-M6x22	ABPL-01	AAL-03-3
ADKT-123-R/L-1616-1.5-R15	●	○	16	16	100	16.3	15				
ADKT-123-R/L-1616-2-T15	●	●	16	16	100	16.3	15	123 - 2	2004-M8x1x20	-	AAL-05-4
ADKT-123-R/L-2020-2-T15	●	●	20	20	125	20.3	15				
ADKT-123-R/L-2525-2-T15	●	●	25	25	150	25.3	15	123 - 3	-	-	-
ADKT-123-R/L-3232-2-T15	●	●	32	32	170	32.3	15				
ADKT-123-R/L-1616-3-T15	●	●	16	16	100	16.4	15	123 - 4	2004-M8x1x20	-	AAL-05-4
ADKT-123-R/L-2020-3-T20	●	●	20	20	125	20.4	20				
ADKT-123-R/L-2525-3-T22	●	●	25	25	150	25.4	22	123 - 5	-	-	-
ADKT-123-R/L-2020-4-T20	●	●	20	20	125	20.4	20				
ADKT-123-R/L-2525-4-T22	●	●	25	25	150	25.4	22	123 - 5	-	-	-
ADKT-123-R/L-3232-4-T25	●	●	32	32	170	32.4	25				
ADKT-123-R/L-2020-5-T20	●	●	20	20	125	20.5	20	123 - 5	-	-	-
ADKT-123-R/L-2525-5-T25	●	●	25	25	150	25.5	25				

R: Sağ/Right L: Sol/Left ● Stokta/In Stock ○ Stokta Yok/Non Stock Item
SNDVK Ucuna Uygundur. / Compatible with SNDVK Insert.

Sipariş Örneği/Ordering Example : 1 ad./pcs. ADKT-ZCC1-R-2020-3-T20

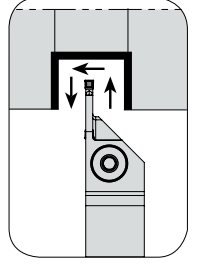
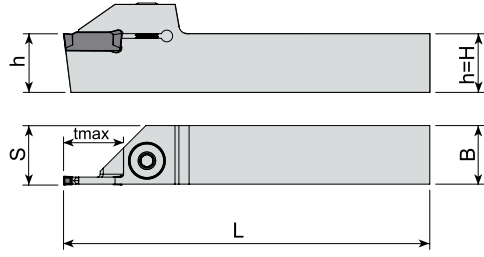

Takım Kodu Ordering Code	Stok Stock		Takım Ölçüleri (mm) Dimension (mm)					Kesici Uç Insert	Yedek Parçaları Spare Parts		
	R	L	h=H	B	L	S	t max		Sıkma Vidası Clamp Screw	Pul Stamp	Anahtar Allen Key
ADKT-I-R/L-1212-2-T15	●	●	12	12	100	12.3	15	DGN - 2	AKV-02-M6x22	ABPL-01	AAL-03-3
ADKT-I-R/L-1616-2-T15	●	●	16	16	100	16.3	15				
ADKT-I-R/L-2020-2-T15	●	●	20	20	125	20.3	15				
ADKT-I-R/L-2525-2-T15	●	●	25	25	150	25.3	15	DGN - 3			
ADKT-I-R/L-1212-3-T15	●	●	12	12	100	12.3	15				
ADKT-I-R/L-1616-3-T15	●	●	16	16	100	16.4	15				
ADKT-I-R/L-2020-3-T20	●	●	20	20	125	20.4	20				
ADKT-I-R/L-2525-3-T22	●	●	25	25	150	25.4	22				
ADKT-I-R/L-2020-4-T20	●	●	20	20	125	20.4	20	DGN / GRP - 4	2004-M8x1x20	-	AAL-05-4
ADKT-I-R/L-2525-4-T22	●	●	25	25	150	25.4	22				
ADKT-I-R/L-2020-5-T20	●	●	20	20	125	20.5	20	DGN / GRP - 5	2004-M8x1x20	-	AAL-05-4
ADKT-I-R/L-2525-5-T25	●	●	25	25	150	25.5	25				
ADKT-IG-R/L-2020-3-R20	●	●	20	20	125	20.4	20	GRP - 3			
ADKT-IG-R/L-2525-3-T22	●	●	25	25	150	25.4	22	GIM / GIP - 2	AKV-02-M6x22	ABPL-01	AAL-03-3
ADKT-IGI-R/L-2020-2-T15	●	●	20	20	125	20.3	15				
ADKT-IGI-R/L-2525-2-T15	●	●	25	25	150	25.4	15				
ADKT-IGI-R/L-1616-3-T15	●	●	16	16	100	16.4	15				
ADKT-IGI-R/L-2020-3-T20	●	●	20	20	125	20.4	20				
ADKT-IGI-R/L-2525-3-T22	●	●	25	25	150	25.4	22				
ADKT-IGI-R/L-2525-4-T22	●	●	25	25	150	25.5	22				
ADKT-IGI-R/L-2525-5-T25	●	●	25	25	150	25.6	25				
ADKT-IGI-R/L-2525-8-T30	●	●	25	25	150	25.8	30	GIM / GIP - 8			
ADKT-IGTN-R/L-2525-5-T25	●	●	25	25	150	25.6	25	GTN - 5			

R: Sağ/Right L: Sol/Left ● Stokta/In Stock ○ Stokta Yok/Non Stock Item
ISCR Ucuna Uygunudur. / Compatible With ISCR Insert

Sipariş Örneği/Ordering Example : 1 ad./pcs. ADKT-I-R-1212-2-T15

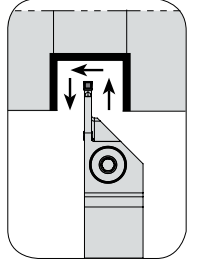
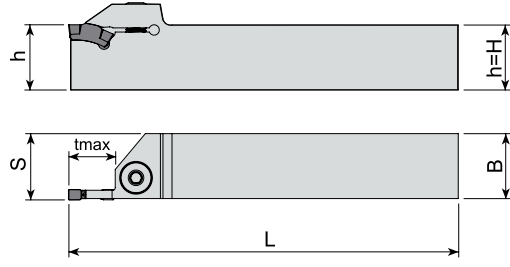

Takım Kodu Ordering Code	Stok Stock		Takım Ölçüleri (mm) Dimension (mm)					Kesici Uç Insert	Yedek Parçaları Spare Parts		
	R	L	h=H	B	L	S	t _{max}		Sıkma Vidası Clamp Screw	Pul Stamp	Anahtar Allen Key
ADKT-ITG-R/L-2020-3-T8	●	●	20	20	125	20.3	8	TGM. - 3	2004-M8x1x20	-	AAL-05-4
ADKT-ITG-R/L-2525-3-T8	●	●	25	25	150	25.3	8				
ADKT-ITG-R/L-3232-3-T8	●	●	32	32	170	32.3	8				
ADKT-ITG-R/L-2020-4-T9	●	●	20	20	125	20.4	9	TGM. - 4	2004-M8x1x20	-	AAL-05-4
ADKT-ITG-R/L-2525-4-T17	●	●	25	25	150	25.4	17				
ADKT-ITG-R/L-3232-4-T17	●	●	32	32	170	32.4	17				

ISCR Ucuna Uygun. / Compatible with ISCR Insert.

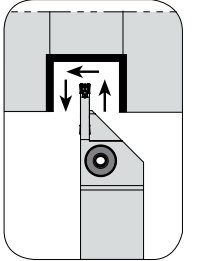
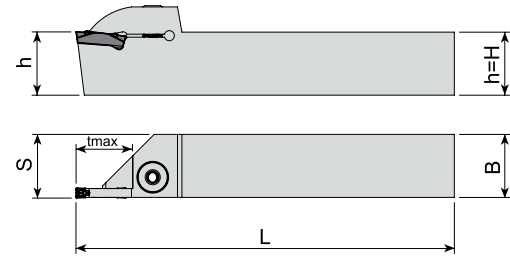

Takım Kodu Ordering Code	Stok Stock		Takım Ölçüleri (mm) Dimension (mm)					Kesici Uç Insert	Yedek Parçaları Spare Parts		
	R	L	h=H	B	L	S	t _{max}		Sıkma Vidası Clamp Screw	Pul Stamp	Anahtar Allen Key
ADKT-KM-R/L-2020-2-T15	●	●	20	20	125	20.3	15	A4. - 2	AKV-02-M6x22	ABPL-01	AAL-03-3
ADKT-KM-R/L-2525-2-T15	●	●	25	25	150	25.3	15				
ADKT-KM-R/L-2020-3-T20	●	●	20	20	125	20.4	20	A4. - 3	2004-M8x1x20	-	AAL-05-4
ADKT-KM-R/L-2525-3-T22	●	●	25	25	150	25.4	22				
ADKT-KM-R/L-2525-4-T22	●	●	25	25	150	25.5	22				

R: Sağ/Right L: Sol/Left ● Stokta/In Stock ○ Stokta Yok/Non Stock Item

KNMNTL Ucuna Uygun. / Compatible with KNMNTL Insert.

Sipariş Örneği/Ordering Example : 1 ad./pcs. ADKT-ITG-R-2020-3-T8

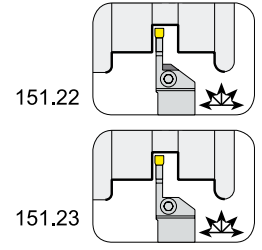
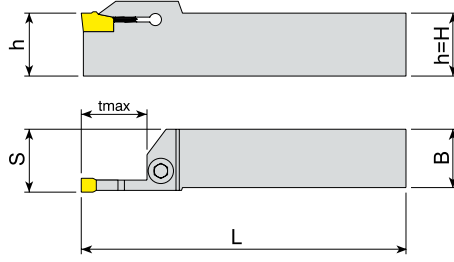

Takım Kodu Ordering Code	Stok Stock		Takım Ölçüleri (mm) Dimension (mm)					Kesici Uç Insert	Yedek Parçaları Spare Parts		
	R	L	h=H	B	L	S	t max		Sıkma Vidası Clamp Screw	Pul Stamp	Anahtar Allen Key
ADKT-151.22-R/L-1616-2-T15	●	●	16	16	100	16.3	15	151.2 - 2	AKV-02-M6x22	ABPL-01	AAL-03-3
ADKT-151.22-R/L-2020-2-T15	●	●	20	20	125	20.3	15				
ADKT-151.22-R/L-2525-2-T15	●	●	25	25	150	25.3	15				
ADKT-151.22-R/L-1616-3-T15	●	●	16	16	100	16.4	15	151.2 - 3	2004-M8x1x20	-	AAL-05-4
ADKT-151.22-R/L-2020-3-T20	●	●	20	20	125	20.4	20				
ADKT-151.22-R/L-2525-3-T22	●	●	25	25	150	25.4	22				
ADKT-151.22-R/L-1616-4-T15	●	●	16	16	100	16.4	15	151.2 - 4	2004-M8x1x20	-	AAL-05-4
ADKT-151.22-R/L-2020-4-T20	●	●	20	20	125	20.4	20				
ADKT-151.22-R/L-2525-4-T22	●	●	25	25	150	25.4	22				
ADKT-151.22-R/L-2020-5-T20	●	●	20	20	125	20.5	20	151.2 - 5	2004-M8x1x20	-	AAL-05-4
ADKT-151.22-R/L-2525-5-T25	●	●	25	25	150	25.5	25				
ADKT-151.23-R/L-1616-2-T15	●	●	16	16	100	16.3	15	151.2 - 2	AKV-02-M6x22	ABPL-01	AAL-03-3
ADKT-151.23-R/L-2020-2-T15	●	●	20	20	125	20.3	15				
ADKT-151.23-R/L-2525-2-T15	●	○	25	25	150	25.3	15				
ADKT-151.23-R/L-1616-2.5-T15	●	●	16	16	100	16.3	15	151.2 - 2.5	2004-M8x1x20	-	AAL-05-4
ADKT-151.23-R/L-2020-2.5-T15	●	●	20	20	125	20.3	15				
ADKT-151.23-R/L-2525-2.5-T15	●	●	25	25	150	25.3	15				
ADKT-151.23-R/L-1212-3-T15	●	●	12	12	100	12.4	15	151.2 - 3	2004-M8x1x20	-	AAL-05-4
ADKT-151.23-R/L-1616-3-T15	●	●	16	16	100	16.4	15				
ADKT-151.23-R/L-2020-3-T20	●	●	20	20	125	20.4	20				
ADKT-151.23-R/L-2525-3-T20	●	●	25	25	150	25.4	20	151.2 - 4	2004-M8x1x20	-	AAL-05-4
ADKT-151.23-R/L-2525-3-T22	●	●	25	25	150	25.4	22				
ADKT-151.23-R/L-1616-4-T15	●	●	16	16	100	16.4	15				
ADKT-151.23-R/L-2020-4-T20	●	●	20	20	125	20.4	20	151.2 - 5	2004-M8x1x20	-	AAL-05-4
ADKT-151.23-R/L-2525-4-T22	●	●	25	25	150	25.4	22				
ADKT-151.23-R/L-2020-5-T20	●	●	20	20	125	20.5	20	151.2 - 5	2004-M8x1x20	-	AAL-05-4
ADKT-151.23-R/L-2525-5-T25	●	●	25	25	150	25.5	25				

R: Sağ/Right L: Sol/Left ● Stokta/In Stock ○ Stokta Yok/Non Stock Item
SNDVK Ucuna Uygundur. / Compatible with SNDVK Insert.

Sipariş Örneği/Ordering Example : 1 ad./pcs. ADKT-151.22-R-1616-2-T15

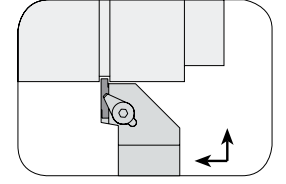
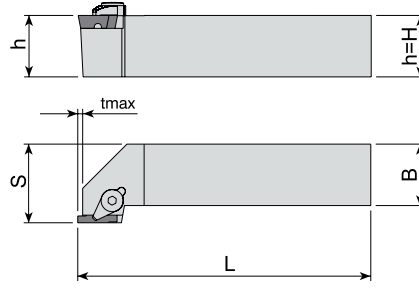

Takım Kodu Ordering Code	Stok Stock	Takım Ölçüleri (mm) Dimension (mm)						Kesici Uç Insert	Yedek Parçaları Spare Parts			
		R	L	h=H	B	L	S		t max	Baskı Parçası Wedge Clamp	Sıkma Vidası Clamp Screw	Pim Pin
ADKT-154-91-R/L-2020-3-T4	●	●	20	20	125	20.4	4		ACK-03	AKV-07-M6x22	APM-06	AAL-03-3
ADKT-154-91-R/L-2525-3-T4	●	●	25	25	150	25.4	4					
ADKT-154-91-R/L-2020-5-T5	●	●	20	20	125	20.5	5		ACK-03	AKV-07-M6x22	APM-06	AAL-03-3
ADKT-154-91-R/L-2525-5-T5	●	●	25	25	150	25.5	5					

SNDVK Ucuna Uygundur. / Compatible with SNDVK Insert.

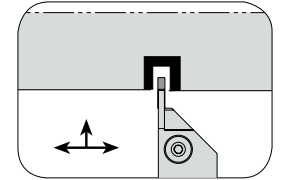
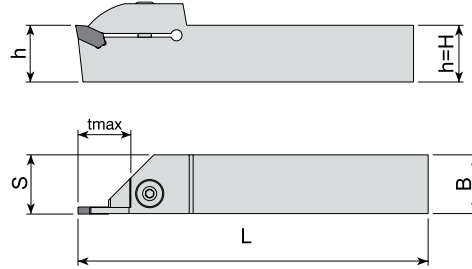

Takım Kodu Ordering Code	Stok Stock	Takım Ölçüleri (mm) Dimension (mm)						Kesici Uç Insert	Yedek Parçaları Spare Parts		
		R	L	h=H	B	L	S		t max	Sıkma Vidası Clamp Screw	Pul Stamp
ADKT-ARN-R/L-2020-2-T15	●	●	20	20	125	20.3	15		AKV-02-M6x22	ABPL-01	AAL-03-3
ADKT-ARN-R/L-2525-2-T15	●	●	25	25	150	25.3	15				
ADKT-ARN-R/L-2020-3-T20	●	●	20	20	125	20.4	20		2004-M8x1x20	-	AAL-05-4
ADKT-ARN-R/L-2525-3-T22	●	●	25	25	150	25.4	22				

R: Sağ/Right L: Sol/Left ● Stokta/In Stock ○ Stokta Yok/Non Stock Item
ARN Ucuna Uygundur. / Compatible with ARN Insert.

Sipariş Örneği/Ordering Example : 1 ad./pcs. ADKT-154.91-R-2020-3-T4

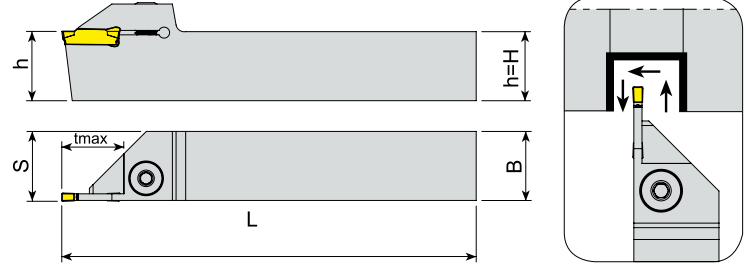

Takım Kodu Ordering Code	Stok Stock		Takım Ölçüleri (mm) Dimension (mm)					Kesici Uç Insert	Yedek Parçaları Spare Parts		
	R	L	h=H	B	L	S	t max		Sıkma Vidası Clamp Screw	Pul Stamp	Anahtar Allen Key
ADKT-TD-R/L-1212-2-T15	●	●	12	12	100	12.3	15	TD. - 2	AKV-02-M6x22	ABPL-01	AAL-03-3
ADKT-TD-R/L-1616-2-T15	●	●	16	16	100	16.3	15				
ADKT-TD-R/L-2020-2-T15	●	○	20	20	125	20.3	15				
ADKT-TD-R/L-2525-2-T17	●	○	25	25	150	25.3	17				
ADKT-TD-R/L-1212-3-T15	●	○	12	12	100	12.3	15	TD. - 3	2004-M8x1x20	-	AAL-05-4
ADKT-TD-R/L-1616-3-T15	●	●	16	16	100	16.4	15				
ADKT-TD-R/L-2020-3-T20	●	●	20	20	125	20.4	20				
ADKT-TD-R/L-2525-3-T9	●	●	25	25	150	25.4	9				
ADKT-TD-R/L-2525-3-T22	●	●	25	25	150	25.4	22	TD. - 4			
ADKT-TD-R/L-2525-4-T22	●	●	25	25	150	25.5	22				
ADKT-TD-R/L-2525-5-T25	●	●	25	25	150	25.5	22	TD. - 5			

TGTC Ucuna Uygun. / Compatible With TGTC Insert.

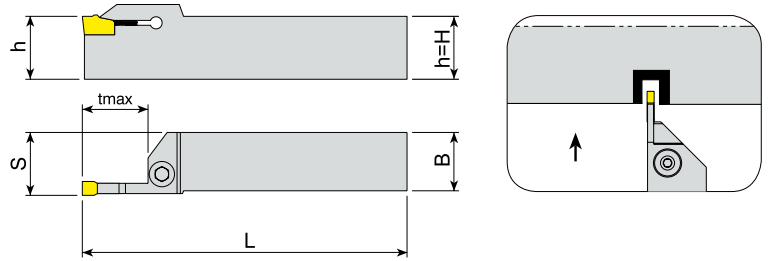

Takım Kodu Ordering Code	Stok Stock		Takım Ölçüleri (mm) Dimension (mm)					Kesici Uç Insert	Yedek Parçaları Spare Parts		
	R	L	h=H	B	L	S	t max		Sıkma Vidası Clamp Screw	Pul Stamp	Anahtar Allen Key
ADKT-SWC-R/L-2020-2-T25	●	○	20	20	125	20.3	25	WCF. - 2	AKV-02-M6x22	ABPL-01	AAL-03-3
ADKT-SWC-R/L-2020-3-T25	●	○	20	20	125	20.4	25	WCF. - 3	2004-M8x1x20	-	AAL-05-4

R: Sağ/Right L: Sol/Left ● Stokta/In Stock ○ Stokta Yok/Non Stock Item
SMTM Ucuna Uygun. / Compatible with SMTM Insert.

Sipariş Örneği/Ordering Example : 1 ad./pcs. ADKT-TD-R-1212-2-T15

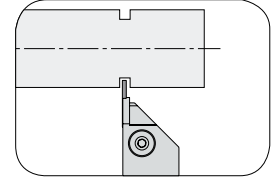
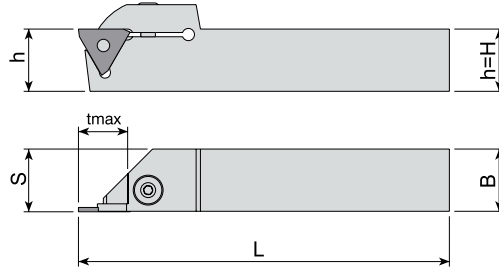

Takım Kodu Ordering Code	Stok Stock		Takım Ölçüleri (mm) Dimension (mm)					Kesici Uç Insert	Yedek Parçaları Spare Parts			
	R	L	h=H	B	L	S	t _{max}		Sıkma Vidası Clamp Screw	Pul Stamp	Anahtar Allen Key	
ADKT-H22-R/L-1616-(0.5-2)-T6	●	●	16	16	100	16.2	6				-	AAL-05-4
ADKT-H22-R/L-2020-(0.5-2)-T6	●	●	20	20	125	20.2	6					
ADKT-H22-R/L-2525-(0.5-2)-T6	●	●	25	25	150	25.2	6					

HRN Ucuna Uygun. / Compatible with HRN Insert.

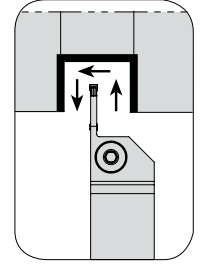
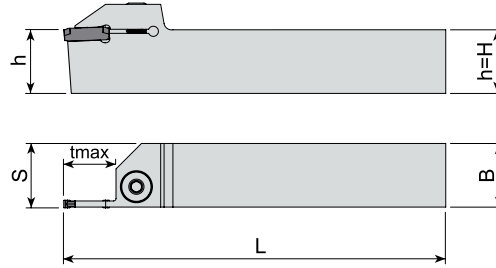



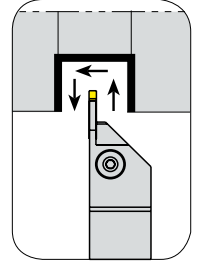
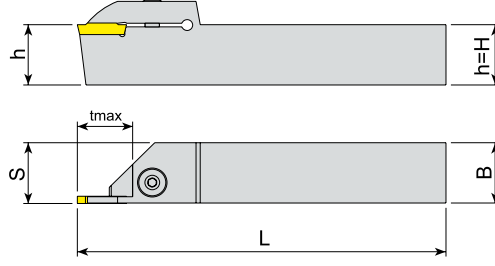

Takım Kodu Ordering Code	Stok Stock		Takım Ölçüleri (mm) Dimension (mm)					Kesici Uç Insert	Yedek Parçaları Spare Parts			
	R	L	h=H	B	L	S	t _{max}		Sıkma Vidası Clamp Screw	Pul Stamp	Anahtar Allen Key	
ADKT-LGC-R/L-1616-2-D40	●	●	16	16	125	16.2	20		AKV-02-M6x22	ABPL-01	-	AAL-03-3
ADKT-LGC-R/L-2020-2-D40	●	●	20	20	125	20.2	20					
ADKT-LGC-R/L-2525-2-D40	●	●	25	25	150	25.2	20					
ADKT-LGC-R/L-1616-3-T20	●	●	16	16	125	16.3	20		2004-M8x1x20	-	-	AAL-05-4
ADKT-LGC-R/L-2020-3-T20	●	●	20	20	125	20.3	20					
ADKT-LGC-R/L-2525-3-T20	●	●	25	25	150	25.3	20					

R: Sağ/Right L: Sol/Left ● Stokta/In Stock ○ Stokta Yok/Non Stock Item
LMN Ucuna Uygun. / Compatible with LMN Insert.

Sipariş Örneği/Ordering Example : 1 ad./pcs. ADKT-H22-R-1616-(0.5-2)T16

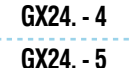

Takım Kodu Ordering Code	Stok Stock		Takım Ölçüleri (mm) Dimension (mm)					Kesici Uç Insert	Yedek Parçaları Spare Parts		
	R	L	h=H	B	L	S	t max		Sıkma Vidası Clamp Screw	Pul Stamp	Anahtar Allen Key
ADKT-WGX24-R/L-2525-4-T22	●	●	25	25	150	25.4	22				
ADKT-WGX24-R/L-2525-5-T25	●	●	25	25	150	25.5	25		2004-M8x1x20	-	AAL-05-4

R: Sağ/Right L: Sol/Left ● Stokta/In Stock ○ Stokta Yok/Non Stock Item
WLTR Ucuna Uygunur. / Compatible with WLTR Insert.

Sipariş Örneği/Ordering Example : 1 ad./pcs. ADKT-WGX24-R-2525-4-T22



DIŞ ÇAP KANAL AÇMA İSVEÇ TİPİ KAYAR OTOMAT MAKİNA TAKIMLARI
EXTERNAL GROOVING TOOLHOLDERS FOR SWISS TYPE SLIDING AUTOMATIC LATHES

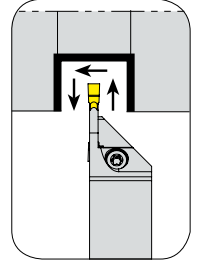
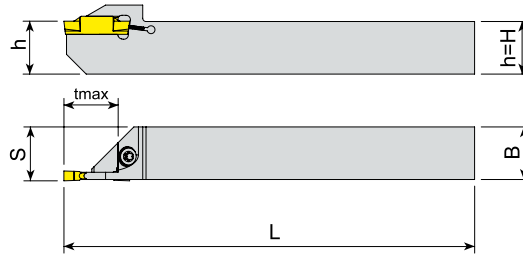

Takım Kodu Ordering Code	Stok Stock		Takım Ölçüleri (mm) Dimension (mm)				Kesici Uç Insert	Yedek Parçaları Spare Parts			
	R	L	h=H	B	L	S		t _{max}	Sıkma Vidası Clamp Screw	Pul Stamp	Tork Anahtar Torx Key
ADKT-TD-R/L-1212-2-T12-K-S	●	●	12	12	125	12.2	12	TD - 2	1515-M4x11	-	80-T15
ADKT-TD-R/L-1616-2-T16-K-S	●	●	16	16	125	16.2	16				
ADKT-TD-R/L-1212-3-T12-K-S	●	●	12	12	125	12.3	12	TD - 3	-	-	-
ADKT-TD-R/L-1616-3-T16-K-S	●	●	16	16	125	16.3	16				

TGTC Ucuna Uygun. / Compatible with TGTC Insert.

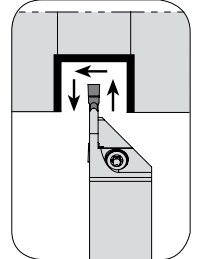
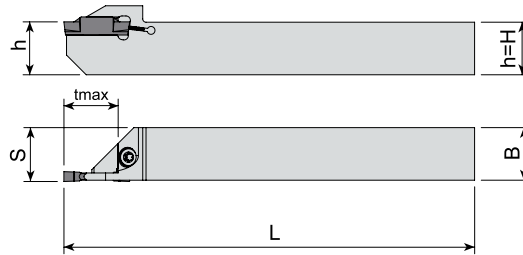

Takım Kodu Ordering Code	Stok Stock		Takım Ölçüleri (mm) Dimension (mm)				Kesici Uç Insert	Yedek Parçaları Spare Parts			
	R	L	h=H	B	L	S		t _{max}	Sıkma Vidası Clamp Screw	Pul Stamp	Tork Anahtar Torx Key
ADKT-ZCC2-R/L-1010-2-T12-K-S	●	●	10	125	125	10.2	12	ZT.D - 2	1515-M4x11	-	80-T15
ADKT-ZCC2-R/L-1212-2-T12-K-S	●	●	12	125	125	12.2	12				
ADKT-ZCC2-R/L-1616-2-R16-K-S	●	●	16	125	125	16.2	16	ZT.D - 3	-	-	-
ADKT-ZCC2-R/L-1212-3-T12-K-S	●	●	12	125	125	12.3	12				

R: Sağ/Right L: Sol/Left ● Stokta/In Stock ○ Stokta Yok/Non Stock Item
ZCC Ucuna Uygun. / Compatible with ZCC Insert.

Sipariş Örneği/Ordering Example : 1 ad./pcs. ADKT-TD-R-1212-2-T12-K-S

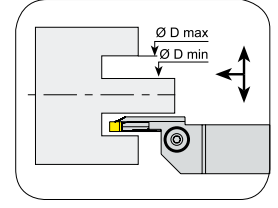
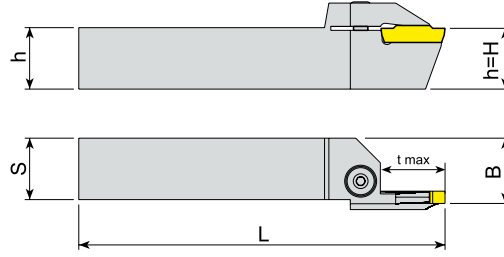

Takım Kodu Ordering Code	Stok Stock		Takım Ölçüleri (mm) Dimension (mm)							Kesici Uç Insert	Yedek Parçaları Spare Parts		
	R	L	h=H	B	L	S	t max	Ø D min	Ø D max		Sıkma Vidası Clamp Screw	Pul Stamp	Anahtar Allen Key
AAKT-K-R/L-2525-34-45-3-T17	●	●	25	25	150	26.5	17	34	45	MGM. - 3			
AAKT-K-R/L-2525-39-55-3-T17	●	●	25	25	150	26.5	17	39	55				
AAKT-K-R/L-2525-49-80-3-T17	●	●	25	25	150	26.5	17	49	80				
AAKT-K-R/L-2525-70-110-3-T17	●	●	25	25	150	26.5	17	70	110				
AAKT-K-R/L-2525-100-150-3-T17	●	●	25	25	150	26.5	17	100	150				
AAKT-K-R/L-2525-80-180-3-T32	●	○	25	25	150	26.5	32	80	180				
AAKT-K-R/L-2525-50-85-4-T22	●	●	25	25	150	26.5	22	50	85	MGM. - 4	2004-M8x1x20	-	AAL-05-4
AAKT-K-R/L-2525-70-110-4-T22	●	●	25	25	150	26.5	22	70	110				
AAKT-K-R/L-2525-100-150-4-T22	●	●	25	25	150	26.5	22	100	150				
AAKT-K-R/L-2525-80-180-4-T32	●	○	25	25	150	26.5	32	80	180				
AAKT-K-R/L-2525-180-800-4-T32	●	○	25	25	150	26.5	32	180	800				
AAKT-K-R/L-2525-70-110-5-T25	●	●	25	25	150	26.5	25	70	110	MGM. - 5			
AAKT-K-R/L-2525-100-150-5-T25	●	●	25	25	150	26.5	25	100	150				
AAKT-K-R/L-2525-80-180-5-T32	●	○	25	25	150	26.5	32	80	180				
AAKT-K-R/L-2525-140-200-5-T25	●	●	25	25	150	26.5	25	140	200	MGM. - 6			
AAKT-K-R/L-2525-180-800-5-T32	●	○	25	25	150	26.5	32	180	800				
AAKT-K-R/L-2525-140-300-6-T35	●	○	25	25	150	26.5	35	140	300	MGM. - 8			
AAKT-K-R/L-2525-140-300-8-T35	●	○	25	25	150	26.5	35	140	300				
AAKT-K-R/L-3232-140-350-8-T35	●	○	32	32	150	32.5	35	140	350				

R: Sağ/Right L: Sol/Left ● Stokta/In Stock ○ Stokta Yok/Non Stock Item
KRLY Ucuna Uygunudur. / Compatiple with KRLY Insert.

Sipariş Örneği/Ordering Example : 1 ad./pcs. AAKT-K-R-2525-34-45-3-T17

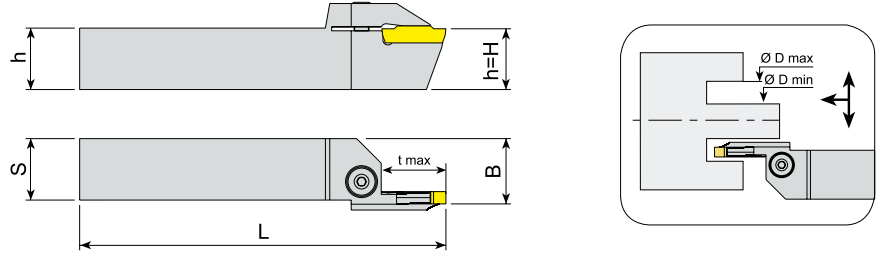

Takım Kodu Ordering Code	Stok Stock		Takım Ölçüleri (mm) Dimension (mm)							Kesici Uç Insert	Yedek Parçaları Spare Parts		
	R	L	h=H	B	L	S	t max	Ø D min	Ø D max		Sıkma Vidası Clamp Screw	Pul Stamp	Anahtar Allen Key
	AAKT-KG-R/L-2525-44-70-4-T22	○	○	25	25	150	26.5	22	44		70	KG.. - 4	2004-M8x1x20
AAKT-KG-R/L-2525-60-120-4-T22	○	○	25	25	150	26.5	22	60	120				
AAKT-KG-R/L-2525-112-200-4-T22	○	○	25	25	150	26.5	22	112	200				

KRLY Ucuna Uygundur. / Compatible with KRLY Insert.

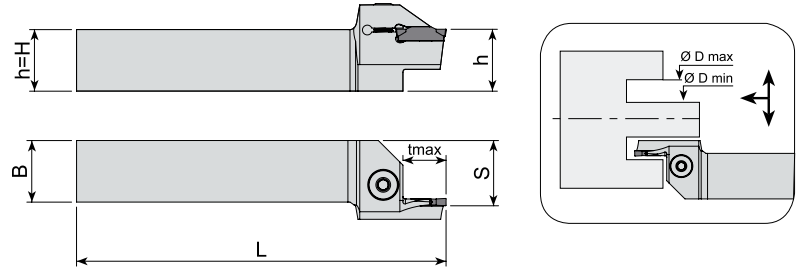

Takım Kodu Ordering Code	Stok Stock		Takım Ölçüleri (mm) Dimension (mm)							Kesici Uç Insert	Yedek Parçaları Spare Parts		
	R	L	h=H	B	L	S	t max	Ø D min	Ø D max		Sıkma Vidası Clamp Screw	Pul Stamp	Anahtar Allen Key
	AAKT-ZCC2-R/L-2525-35-45-3-T17	●	○	25	25	150	26.5	17	35		45	ZT.D - 3	2004-M8x1x20
AAKT-ZCC2-R/L-2525-39-55-3-T17	●	○	25	25	150	26.5	17	39	55				
AAKT-ZCC2-R/L-2525-49-80-3-T17	●	●	25	25	150	26.5	17	49	80				
AAKT-ZCC2-R/L-2525-70-110-3-T17	●	●	25	25	150	26.5	17	70	110	ZT.D - 4	2004-M8x1x20	-	AAL-05-4
AAKT-ZCC2-R/L-2525-100-150-3-T17	●	○	25	25	150	26.5	17	100	150				
AAKT-ZCC2-R/L-2525-40-60-4-T22	●	○	25	25	150	26.5	22	40	60				
AAKT-ZCC2-R/L-2525-52-80-4-T22	●	○	25	25	150	26.5	22	52	80	ZT.D - 5	2004-M8x1x20	-	AAL-05-4
AAKT-ZCC2-R/L-2525-72-110-4-T22	●	○	25	25	150	26.5	22	72	110				
AAKT-ZCC2-R/L-2525-100-150-4-T22	●	○	25	25	150	26.5	22	100	150				
AAKT-ZCC2-R/L-2525-140-200-4-T22	●	○	25	25	150	26.5	22	140	200	ZT.D - 5	2004-M8x1x20	-	AAL-05-4
AAKT-ZCC2-R/L-2525-55-95-5-T25	●	○	25	25	150	26.5	25	55	95				
AAKT-ZCC2-R/L-2525-85-140-5-T25	●	○	25	25	150	26.5	25	85	140				
AAKT-ZCC2-R/L-2525-130-200-5-T25	●	○	25	25	150	26.5	25	130	200	ZT.D - 5	2004-M8x1x20	-	AAL-05-4
AAKT-ZCC2-R/L-2525-190-400-5-T25	●	○	25	25	150	26.5	25	190	400				

R: Sağ/Right L: Sol/Left ● Stokta/In Stock ○ Stokta Yok/Non Stock Item
ZCC Ucuna Uygundur. / Compatible with ZCC Insert.

Sipariş Örneği/Ordering Example : 1 ad./pcs. AAKT-KG-R-2525-44-70-4-T22

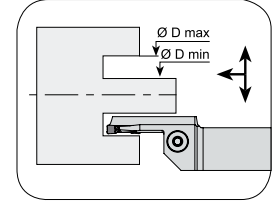
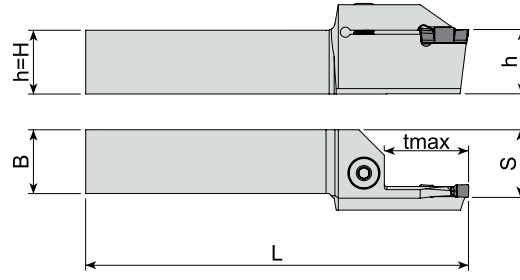

Takım Kodu Ordering Code	Stok Stock		Takım Ölçüleri (mm) Dimension (mm)							Kesici Uç Insert	Yedek Parçaları Spare Parts		
	R	L	h=H	B	L	S	t max	Ø D min	Ø D max		Sıkma Vidası Clamp Screw	Pul Stamp	Anahtar Allen Key
AAKT-IG-R/L-2525-40-60-4-T25	○	○	25	25	150	26.5	25	40	60	DGN / GRP - 4	2004-M8x1x20	-	AAL-05-4
AAKT-IG-R/L-2525-52-80-4-T25	○	○	25	25	150	26.5	25	52	80				
AAKT-IG-R/L-2525-70-110-4-T28	●	○	25	25	150	26.5	28	70	110				
AAKT-IG-R/L-2525-72-110-4-T25	○	○	25	25	150	26.5	25	72	110				
AAKT-IG-R/L-2525-100-150-4-T25	○	○	25	25	150	26.5	25	100	150				
AAKT-IG-R/L-2525-110-200-4-T28	●	○	25	25	150	26.5	28	110	200				
AAKT-IG-R/L-2525-110-200-4-T32	●	○	25	25	150	26.5	32	110	200				
AAKT-IG-R/L-2525-140-200-4-T25	○	○	25	25	150	26.5	25	140	200				
AAKT-IG-R/L-2525-180-800-4-T28	●	○	25	25	150	26.5	28	180	800				
AAKT-IG-R/L-2525-200-800-4-T25	○	○	25	25	150	26.5	25	200	800				
AAKT-IG-R/L-2525-70-110-5-T32	●	○	25	25	150	26.5	32	70	110	DGN / GRP - 5			
AAKT-IG-R/L-2525-110-200-5-T32	●	●	25	25	150	26.5	32	110	200				
AAKT-IG-R/L-2525-180-800-5-T32	●	●	25	25	150	26.5	32	180	800				
AAKT-IG-R/L-2525-58-100-6-T32	●	○	25	25	150	26.5	32	58	100	DGN / GRP - 6			
AAKT-IG-R/L-2525-88-180-6-T32	●	○	25	25	150	26.5	32	88	180				

R: Sağ/Right L: Sol/Left ● Stokta/In Stock ○ Stokta Yok/Non Stock Item
ISCR Ucuna Uygunudur. / Compatiple with ISCR Insert.

Sipariş Örneği/Ordering Example : 1 ad./pcs. AAKT-IG-R-2525-40-60-4-T25



L TİP ALIN KANAL AÇMA TAKIMLARI
L TYPE FACE EXTERNAL GROOVING TOOLHOLDERS

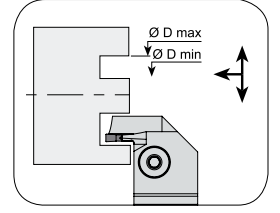
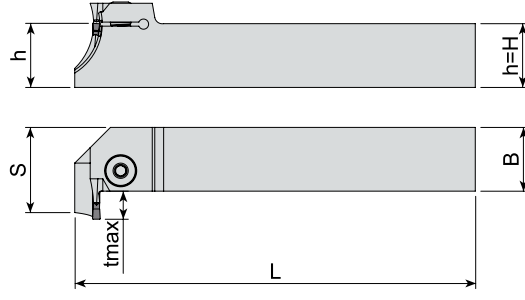

Takım Kodu Ordering Code	Stok Stock		Takım Ölçüleri (mm) Dimension (mm)							Kesici Uç Insert	Yedek Parçaları Spare Parts		
	R	L	h=H	B	L	S	t max	Ø D min	Ø D max		Sıkma Vidası Clamp Screw	Pul Stamp	Anahtar Allen Key
ALKT-ZCC2-R/L-2525-35-45-3-T10	●	○	25	25	150	36	10	35	45	ZT.D - 3	2004-M8x1x20	-	AAL-05-4
ALKT-ZCC2-R/L-2525-39-55-3-T10	●	○	25	25	150	36	10	39	55				
ALKT-ZCC2-R/L-2525-35-∞-3-T4	●	○	25	25	150	30	4	35	∞	ZT.D - 4	2004-M8x1x20	-	AAL-05-4
ALKT-ZCC2-R/L-2525-40-60-4-T14	●	○	25	25	150	40	14	40	60				
ALKT-ZCC2-R/L-2525-52-80-4-T14	●	○	25	25	150	40	14	52	80	ZT.D - 4	2004-M8x1x20	-	AAL-05-4
ALKT-ZCC2-R/L-2525-72-110-4-T14	●	○	25	25	150	40	14	72	110				
ALKT-ZCC2-R/L-2525-100-230-4-T14	●	○	25	25	150	40	14	100	230	ZT.D - 4	2004-M8x1x20	-	AAL-05-4
ALKT-ZCC2-R/L-2525-40-∞-4-T4	●	○	25	25	150	30	4	40	∞				

R: Sağ/Right L: Sol/Left ● Stokta/In Stock ○ Stokta Yok/Non Stock Item
ZCC Ucuna Uygundur. / Compatible with ZCC Insert.

Sipariş Örneği/Ordering Example : 1 ad./pcs. ALKT-ZCC2-R-2525-35-45-3-T10



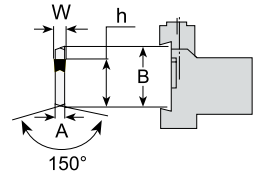
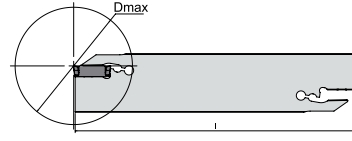
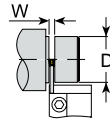

Takım Kodu Ordering Code	Stok Stock	Takım Ölçüleri (mm) Dimension (mm)						Kesici Uç Insert	Yedek Parçaları Spare Parts	
		B	W	A	l	h	D max		Anahtar Key	
AKL-I-26-2	○	26	1.9-2.5	1.6	110	21.4	39	DGN - 2	ALA-01	
AKL-I-32-2	○	32	1.9-2.5	1.8	150	24.8	39			
AKL-I-26-3	○	26	3-3.18	2.4	110	21.4	39	DGN - 3		
AKL-I-32-3	○	32	3-3.18	2.4	150	24.8	39			
AKL-I-26-4	○	26	4	3.2	110	21.4	80	DGN / GRP - 4		
AKL-I-32-4	○	32	4	3.2	150	24.8	100			

ISCR Ucuna Uygun. / Compatible with ISCR Insert.

KESME VE DERİN KANAL AÇMA LAMA BLOĞU
BLOCKS FOR PARTING AND DEEP GROOVING BLADES

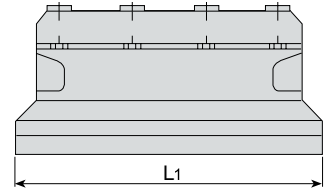
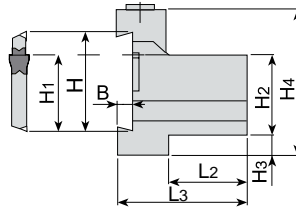

Takım Kodu Ordering Code	Stok Stock	Takım Ölçüleri (mm) Dimension (mm)									Yedek Parçaları Spare Parts		
		H	H1	H2	H3	H4	B	L1	L2	L3	Pabuç Clamp	Pabuç Vidası Clamp Screw	Anahtar Allen Key
ALBU-20-26	●	26	21.4	20	8	38	4	87	19	33	ABK-01	2505-M6x25	AAL-07-5
ALBU-25-26	●	26	21.4	25	3	38	4	110	20	34	ABK-02		
ALBU-20-32	●	32	24.8	20	13	48	5.5	100	19	35	ABK-03	2505-M6x30	
ALBU-25-32	●	32	24.8	25	8	48	5.5	110	20	36	ABK-04		
ALBU-32-32	●	32	24.8	32	3	48	5.5	120	28	44			

R: Sağ/Right L: Sol/Left ● Stokta/In Stock ○ Stokta Yok/Non Stock Item

Sipariş Örneği/Ordering Example : 1 ad./pcs. ALBU-20-26

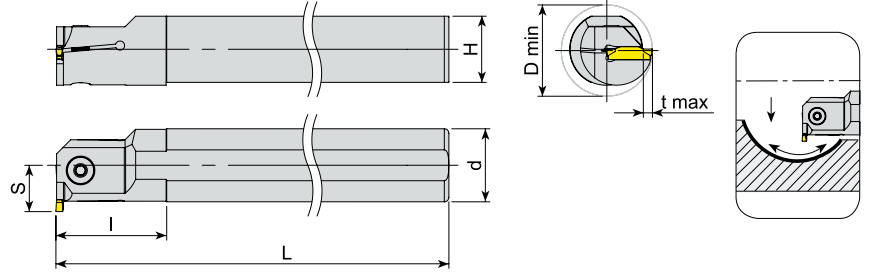

Takım Kodu Ordering Code	Stok Stock		Takım Ölçüleri (mm) Dimension (mm)							Kesici Uç Insert	Yedek Parçaları Spare Parts	
	R	L	d	D	L	l	t max	H	S		Sıkma Vidası Clamp Screw	Anahtar Allen Key
AIKT-K-R/L-16-2-T4	●	●	16	21	150	28	4	14.8	12	MGM. - 2	2503-M4x10	AAL-03-3
AIKT-K-R/L-20-2-T4	●	●	20	25	170	33	4	18.3	14		2503-M4x12	
AIKT-K-R/L-25-2-T6	●	○	25	32	200	40	6	23	18.5			
AIKT-K-R/L-20-3-T6	●	●	20	27	170	33	6	18.3	16	MGM. - 3	2504-M5x12	AAL-05-4
AIKT-K-R/L-20-3-T7	●	○	20	25	170	38	7	18.3	13		2504-M5x16	
AIKT-K-R/L-25-3-T6	●	●	25	32	200	40	6	23	18.5			
AIKT-K-R/L-25-3-T10	●	○	25	32	200	48	10	23	17			
AIKT-K-R/L-32-3-T6	●	●	32	39	250	50	6	30	22			
AIKT-K-R/L-32-3-T12	●	●	32	39	250	53	12	30	22		2004-M8x1x20	
AIKT-K-R/L-40-3-T6	●	●	40	47	300	55	6	37.5	26			
AIKT-K-R/L-40-3-T12	●	○	40	48	300	63	12	37.5	27			
AIKT-K-R/L-20-4-T6	●	●	20	27	170	34	6	18.3	16		MGM. - 4	
AIKT-K-R/L-20-4-T7	●	○	20	25	170	34	7	18.3	13	2504-M5x16		
AIKT-K-R/L-25-4-T6	●	●	25	32	200	40	6	23	18.5			
AIKT-K-R/L-25-4-T10	●	○	25	32	200	48	10	23	17			
AIKT-K-R/L-32-4-T6	●	●	32	39	250	50	6	30	22			
AIKT-K-R/L-32-4-T12	●	○	32	39	250	53	12	30	22	2004-M8x1x20		
AIKT-K-R/L-40-4-T6	●	●	40	47	300	55	6	37.5	27			
AIKT-K-R/L-40-4-T12	●	○	40	48	300	63	12	37.5	27			
AIKT-K-R/L-25-5-T7	●	●	25	33	200	40	7	23	18.5	MGM. - 5	2504-M5x16	2004-M8x1x20
AIKT-K-R/L-32-5-T7	●	●	32	40	250	50	7	30	23			
AIKT-K-R/L-40-5-T7	●	●	40	48	300	55	7	37.5	27			

R: Sağ/Right L: Sol/Left ● Stokta/In Stock ○ Stokta Yok/Non Stock Item
KRLY Ucuna Uygunudur. / Compatiple with KRLY Insert.

Sipariş Örneği/Ordering Example : 1 ad./pcs. AIKT-K-R-16-2-T4

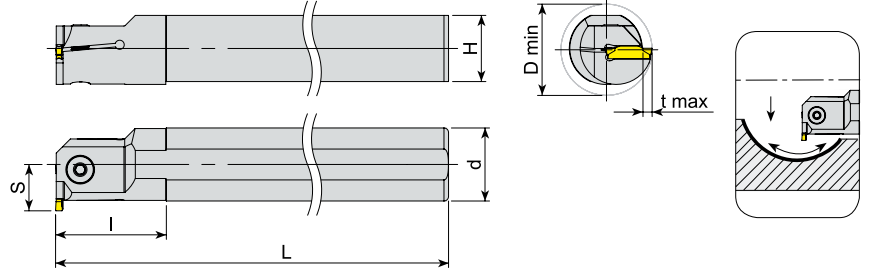

Takım Kodu Ordering Code	Stok Stock		Takım Ölçüleri (mm) Dimension (mm)							Kesici Uç Insert	Yedek Parçaları Spare Parts	
	R	L	d	D	L	I	t max	H	S		Sıkma Vidası Clamp Screw	Anahtar Allen Key
AIKT-KG-R/L-25-2-T7	○	○	25	37	200	40	7	23	19.5	KG.. - 2	2503-M4x12	AAL-03-3
AIKT-KG-R/L-25-3-T7	○	○	25	33	200	40	7	23	19.5	KG.. - 3	2504-M5x16	AAL-05-4
AIKT-KG-R/L-25-4-T8	○	○	25	34	200	40	8	23	20.5	KG.. - 4		

KRLY Ucuna Uygundur. / Compatible with KRLY Insert.

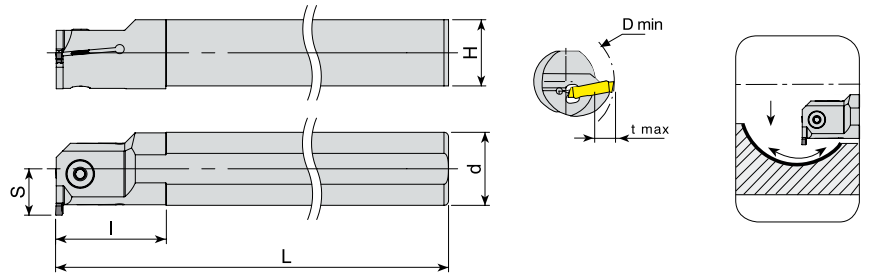

Takım Kodu Ordering Code	Stok Stock		Takım Ölçüleri (mm) Dimension (mm)							Kesici Uç Insert	Yedek Parçaları Spare Parts	
	R	L	d	D	L	I	t max	H	S		Sıkma Vidası Clamp Screw	Anahtar Allen Key
AIKT-H-R/L-25-3-T7	●	●	25	33	200	40	7	23	19.5	S229 - 3	2504-M5x16	AAL-05-4
AIKT-H-R/L-32-3-T7	●	○	32	40	250	50	7	30	23		2004-M8x1x20	
AIKT-H-R/L-40-3-T7	●	●	40	48	300	55	7	37.5	27			
AIKT-H-R/L-25-4-T7	●	●	25	33	200	40	7	23	19.5	S229 - 4	2504-M5x16	
AIKT-H-R/L-32-4-T7	●	●	32	40	250	50	7	30	23		2004-M8x1x20	
AIKT-H-R/L-40-4-T7	●	○	40	48	300	55	7	37.5	27			
AIKT-H-R/L-25-5-T7	●	●	25	33	200	40	7	23	19.5	S229 - 5	2504-M5x16	
AIKT-H-R/L-32-5-T7	●	○	32	40	250	50	7	30	23		2004-M8x1x20	
AIKT-H-R/L-40-5-T7	●	○	40	48	300	55	7	37.5	27			

R: Sağ/Right L: Sol/Left ● Stokta/In Stock ○ Stokta Yok/Non Stock Item
HRN Ucuna Uygundur. / Compatible with HRN Insert.

Sipariş Örneği/Ordering Example : 1 ad./pcs. AIKT-KG-R-25-2-T7

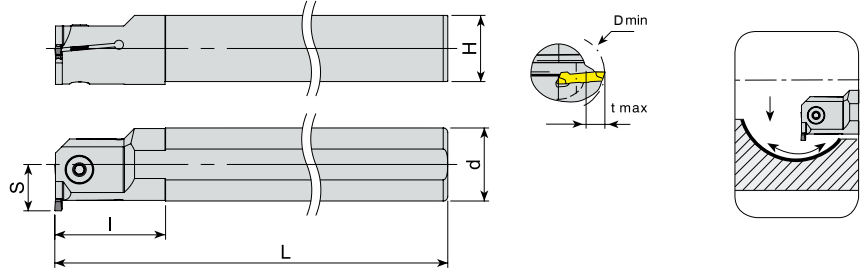

Takım Kodu Ordering Code	Stok Stock		Takım Ölçüleri (mm) Dimension (mm)							Kesici Uç Insert	Yedek Parçaları Spare Parts	
	R	L	d	D	L	l	t max	H	S		Sıkma Vidası Clamp Screw	Anahtar Allen Key
AIKT-HK-R/L-20-2-T6	●	○	20	26	170	33	6	18.3	16	S224 - 2	2503-M4x12	AAL-03-3
AIKT-HK-R/L-25-2-T6	●	○	25	32	200	40	6	23	18.5		2504-M5x16	
AIKT-HK-R/L-20-3-T6	●	○	20	27	170	33	6	18.3	16	S224 - 3	2504-M5x12	AAL-05-4
AIKT-HK-R/L-25-3-T6	●	●	25	32	200	40	6	23	18.5		2504-M5x16	
AIKT-HK-R/L-32-3-T6	●	○	32	39	250	50	6	30	22	S224 - 4	2004-M8x1x20	AAL-05-4
AIKT-HK-R/L-20-4-T6	●	○	20	27	170	33	6	18.3	16		2504-M5x12	
AIKT-HK-R/L-25-4-T6	●	○	25	32	200	40	6	23	18.5	S224 - 4	2504-M5x16	AAL-05-4
AIKT-HK-R/L-32-4-T6	●	○	32	39	250	50	6	30	22		2004-M8x1x20	
AIKT-HS223-R/L-20-2-T5	●	○	20	26	170	33	5	18.3	15	S223 - 2	2503-M4x12	AAL-03-3
AIKT-HS223-R/L-25-2-T5	●	○	25	31	200	40	5	23	17.5		2504-M5x16	
AIKT-HS223-R/L-20-3-T6	●	○	20	27	170	33	6	18.3	16	S223 - 3	2504-M5x12	AAL-05-4
AIKT-HS223-R/L-25-3-T6	●	○	25	32	200	40	6	23	18.5		2504-M5x16	

HRN Ucuna Uygundur. / Compatible with HRN Insert.

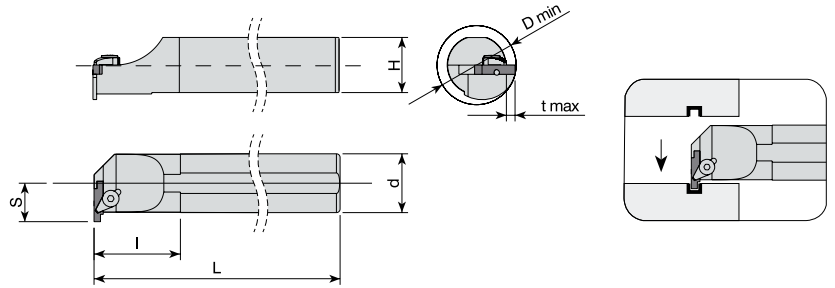

Takım Kodu Ordering Code	Stok Stock		Takım Ölçüleri (mm) Dimension (mm)							Kesici Uç Insert	Yedek Parçaları Spare Parts			
	R	L	d	D	L	l	t max	H	S		Baskı Parçası Wedge Clamp	Sıkma Vidası Clamp Screw	Pim Pin	Anahtar Allen Key
AIKT-154.91-R/L-16-3-T3	●	●	16	20	150	35	3	14.8	11	154.91 - 3	ACK-06	AKV-10-M6x14	APM-06	AAL-05-4
AIKT-154.91-R/L-20-3-T4	●	●	20	25	170	38	4	18.3	14					
AIKT-154.91-R/L-25-3-T4	●	●	25	31	200	40	4	23	16.5	154.91 - 5	ACK-03	AKV-21-M6x18	APM-06	AAL-03-3
AIKT-154.91-R/L-25-5-T5	●	●	25	31	200	45	5	23	17.5					
AIKT-154.91-R/L-32-5-T5	●	●	32	38	250	50	5	30	21		AKV-07-M6x22			

R: Sağ/Right L: Sol/Left ● Stokta/In Stock ○ Stokta Yok/Non Stock Item
SNDVK Ucuna Uygundur. / Compatible with SNDVK Insert.

Sipariş Örneği/Ordering Example : 1 ad./pcs. AIKT-HK-R-20-2-T6

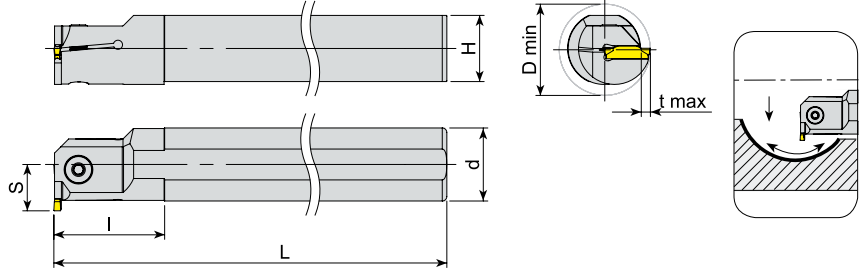

Takım Kodu Ordering Code	Stok Stock		Takım Ölçüleri (mm) Dimension (mm)							Kesici Uç Insert	Yedek Parçaları Spare Parts	
	R	L	d	D	L	I	t max	H	S		Sıkma Vidası Clamp Screw	Anahtar Allen Key
AIKT-ZCC2-R/L-20-3-T5	●	●	20	26	170	33	5	18.3	15	ZT.D - 3	2504-M5x12 2504-M5x16 2004-M8x1x20	AAL-05-4
AIKT-ZCC2-R/L-25-3-T5	●	○	25	31	200	40	5	23	17.5			
AIKT-ZCC2-R/L-32-3-T6	●	○	32	39	250	50	6	30	22			
AIKT-ZCC2-R/L-32-3-T8	●	○	32	41	250	50	8	30	24			
AIKT-ZCC2-R/L-25-4-T6	●	○	25	32	200	40	6	23	17.5	ZT.D - 4	2504-M5x16 2004-M8x1x20	AAL-05-4
AIKT-ZCC2-R/L-32-4-T7	●	○	32	40	250	50	7	30	23			
AIKT-ZCC2-R/L-32-4-T8	●	○	32	41	250	50	8	30	24			
AIKT-ZCC2-R/L-32-4-T10	●	○	32	43	250	50	10	30	26			
AIKT-ZCC2-R/L-32-5-T7	●	○	32	40	250	50	7	30	23	ZT.D - 5	2004-M8x1x20	AAL-05-4
AIKT-ZCC2-R/L-32-5-T8	●	○	32	41	250	50	8	30	24			
AIKT-ZCC2-R/L-40-5-T8	●	○	40	49	300	55	8	37.5	28			
AIKT-ZCC2-R/L-40-5-T10	●	○	40	51	300	55	10	37.5	30			

ZCC Ucuna Uygundur. / Compatible with ZCC Insert.

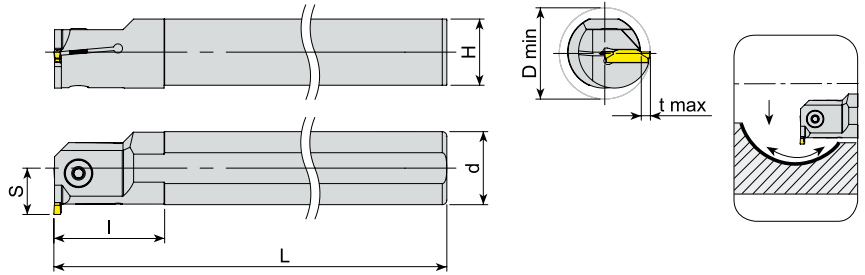

Takım Kodu Ordering Code	Stok Stock		Takım Ölçüleri (mm) Dimension (mm)							Kesici Uç Insert	Yedek Parçaları Spare Parts	
	R	L	d	D	L	I	t max	H	S		Sıkma Vidası Clamp Screw	Anahtar Allen Key
AIKT-KM-R/L-20-2-T7	●	○	20	25	170	40	7	18.3	13	A4. - 2	2503-M4x12 2504-M5x12	AAL-03-3 AAL-05-4
AIKT-KM-R/L-20-3-T7	●	○	20	25	170	40	7	18.3	13			
AIKT-KM-R/L-25-3-T10	●	●	25	32	200	50	10	23	17	A4. - 3	2505-M6x16 2505-M6x20	AAL-07-5
AIKT-KM-R/L-32-3-T12	●	○	32	40	250	64	12	30	22			
AIKT-KM-R/L-40-3-T12	●	●	40	48	300	80	12	37.5	27	A4. - 4	2504-M5x12	AAL-05-4
AIKT-KM-R/L-20-4-T7	●	○	20	25	170	40	7	18.3	13			

R: Sağ/Right L: Sol/Left ● Stokta/In Stock ○ Stokta Yok/Non Stock Item
KNMTL Ucuna Uygundur. / Compatible with KNMTL Insert.

Sipariş Örneği/Ordering Example : 1 ad./pcs. AIKT-ZCC2-R-20-3-T5

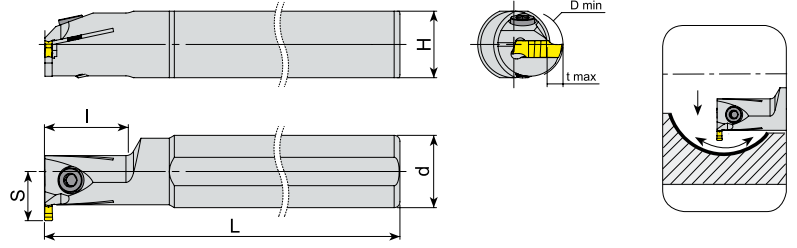

Takım Kodu Ordering Code	Stok Stock		Takım Ölçüleri (mm) Dimension (mm)							Kesici Uç Insert	Yedek Parçaları Spare Parts	
	R	L	d	D	L	l	t max	H	S		Sıkma Vidası Clamp Screw	Anahtar Key
AIKT-IGI-R/L-20-3-T4	●	○	20	25	170	35	4	18.3	14.5	GIMIY / GIPI - 3	1020-M5x14	80-T20
AIKT-IGI-R/L-25-3-T5	●	○	25	30	200	45	5	23	17		2504-M5x16	AAL-05-4
AIKT-IGI-R/L-32-3-T5	○	○	32	40	250	50	5	30	21		2004-M8x1x20	

ISCR Ucuna Uygun. / Compatible with ISCR Insert.

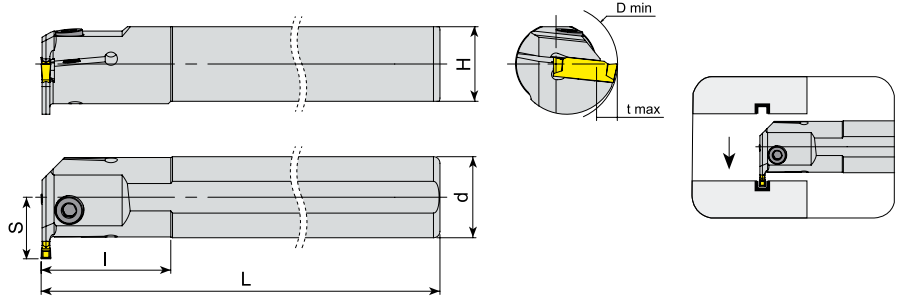

Takım Kodu Ordering Code	Stok Stock		Takım Ölçüleri (mm) Dimension (mm)							Kesici Uç Insert	Yedek Parçaları Spare Parts	
	R	L	d	D	L	l	t max	H	S		Sıkma Vidası Clamp Screw	Anahtar Allen Key
AIKT-I-R/L-20-3-T5	●	○	20	26	170	25	5	18.3	15.5	DGN - 3	2504-M5x12	AAL-05-4
AIKT-I-R/L-25-3-T6	●	○	25	32	200	40	6	23	19		2504-M5x16	

R: Sağ/Right L: Sol/Left ● Stokta/In Stock ○ Stokta Yok/Non Stock Item
ISCR Ucuna Uygun. / Compatible with ISCR Insert.

Sipariş Örneği/Ordering Example : 1 ad./pcs. AIKT-IGI-R-20-3-T4

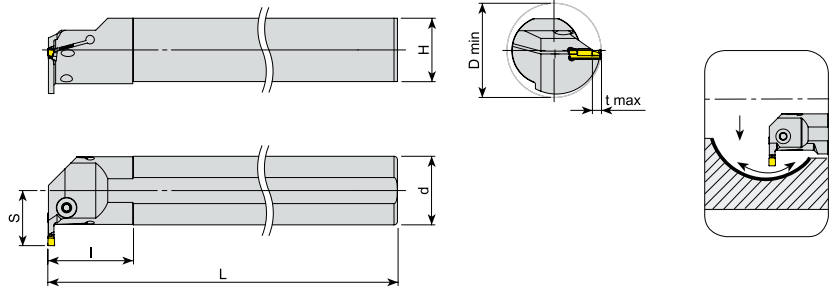

Takım Kodu Ordering Code	Stok Stock		Takım Ölçüleri (mm) Dimension (mm)							Kesici Uç Insert	Yedek Parçaları Spare Parts	
	R	L	d	D	L	l	t max	H	S		Sıkma Vidası Clamp Screw	Anahtar Allen Key
AIKT-IG-R/L-25-4-T10-H	●	○	25	31	200	40	10	23	22.7	DGN / GRP - 4	2504-M5X16	AAL-05-4
AIKT-IG-R/L-32-4-T10-H	●	●	32	37	250	45	10	30	26.2			
AIKT-IG-R/L-40-4-T12-H	●	●	40	45	300	50	12	37.5	32.2			
AIKT-IG-R/L-25-5-T10-H	●	○	25	31	200	40	10	23	22.7	DGN / GRP - 5	2504-M5X16	AAL-05-4
AIKT-IG-R/L-32-5-T10-H	●	○	32	37	250	45	10	30	26.2			
AIKT-IG-R/L-40-5-T12-H	●	○	40	45	300	50	12	37.5	32.2			
AIKT-IG-R/L-50-5-T12-H	●	○	50	60	350	60	12	47	37.2			

ISCR Ucuna Uygundur. / Compatiple with ISCR Insert.

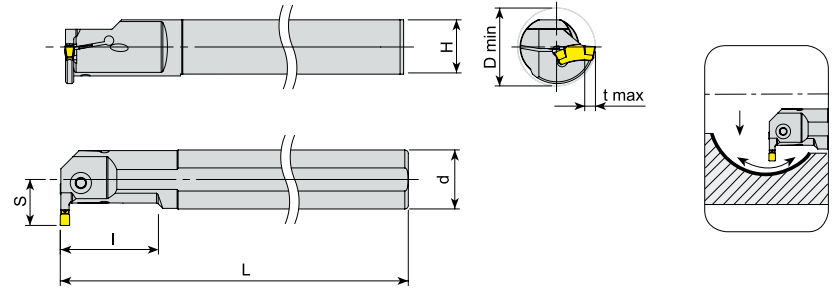





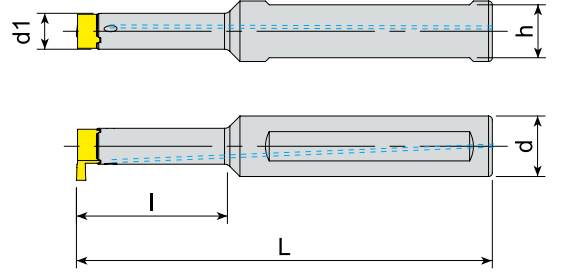

Takım Kodu Ordering Code	Stok Stock		Takım Ölçüleri (mm) Dimension (mm)							Kesici Uç Insert	Yedek Parçaları Spare Parts	
	R	L	d	D	L	l	t max	H	S		Sıkma Vidası Clamp Screw	Anahtar Key
AIKT-ITG-R/L-16-3-T6-H	●	●	16	20	150	35	6	14.8	12	TGM. - 3	1020-M4.5X14	80-T20
AIKT-ITG-R/L-20-3-T6-H	●	●	20	25	170	40	6	18.3	14.2			
AIKT-ITG-R/L-25-3-T8-H	●	●	25	31	200	50	8	23	18.8			
AIKT-ITG-R/L-32-3-T8-H	●	●	32	37	250	60	8	30	22	TGM. - 4	2504-M5X16	AAL-05-4
AIKT-ITG-R/L-20-4-T6-H	●	●	20	25	170	40	6	18.3	14.2			
AIKT-ITG-R/L-25-4-T7-H	●	●	25	31	200	50	7	23	17.5			
AIKT-ITG-R/L-25-4-T9-H	●	●	25	32.5	200	50	9	23	19.5			
AIKT-ITG-R/L-32-4-T11-H	●	●	32	37	250	60	11	30	25.5	2004-M8x1x20	AAL-05-4	
AIKT-ITG-R/L-40-4-T11-H	●	●	40	45	300	50	11	37.5	32			

R: Sağ/Right L: Sol/Left ● Stokta/In Stock ○ Stokta Yok/Non Stock Item
ISCR Ucuna Uygundur. / Compatiple with ISCR Insert.

Sipariş Örneği/Ordering Example : 1 ad./pcs. AIKT-IG-R-25-4-T10-H



Takım Kodu Ordering Code	Stok Stock	Takım Ölçüleri (mm) Dimension (mm)					Kesici Uç Insert	Yedek Parçaları Spare Parts				
		d	d1	L	l	h		Sıkma Vidası Clamp Screw	Tork Anahtar Torx Key			
AIKT-MB07-A16-090-15	●	16	7.4	90	15	14						
AIKT-MB07-A16-090-22	●	16	7.4	90	22	14				MB - 07	4008-M3x8	80-T08
AIKT-MB09-A16-090-19	●	16	9.5	90	19	14						
AIKT-MB09-A16-095-28	●	16	9.5	95	28	14				MB - 09	1515-M4x11	80-T15
AIKT-MB09-A16-110-40	●	16	9.5	110	40	14						

R: Sağ/Right L: Sol/Left ● Stokta/In Stock ○ Stokta Yok/Non Stock Item
SNDVK Ucuna Uygunudur. / Compatible with SNDVK Insert.

Sipariş Örneği/Ordering Example : 1 ad./pcs. AIKT-MB07-R-16-16





DELİK DELME ve İŞLEME TAKIMLARI
DRILLING and HOLEMAKING TOOLS





*konusulan
the spoken kalite...
quality...*

U-DRILL

TAKMA UÇLU MATKAPLAR
U-DRILL SYSTEM





AKKO **A** **TUM** **16** x **D3**

S **P** **G** **T** **06** **02** **04**

2 Kesiş Stili / Cutter Style

TUM : Takma Uçlu Matkap / U-Drill

3 Takım Çapı / Tool Diameter

4 Delme Derinliği / Drilling Depth

D x 2
D x 3
D x 4

5 Uç Şekli / Insert Form

W **S**

6 Serbest Uç Açısı / Clearance angle of Insert

C **P**

8 Uç Tipi / Type of Insert

A J T
 $\beta = 70-90^\circ$ $\beta = 70-90^\circ$ $\beta = 40-60^\circ$

B M U
 $\beta = 70-90^\circ$ $\beta = 40-60^\circ$ $\beta = 40-60^\circ$

C N W
 $\beta = 70-90^\circ$ $\beta = 40-60^\circ$ $\beta = 40-60^\circ$

F Q X Special / Özel

G R

H

$\beta = 70-90^\circ$

10 Kalınlık / Thickness

01 s = 1.59
T1 s = 1.98
02 s = 2.38
T2 s = 2.78
03 s = 3.18
T3 s = 3.97
04 s = 4.76
05 s = 5.56
06 s = 6.35
07 s = 7.94
09 s = 9.52

7 Toleranslar / Tolerance Classes

	d	m	t
A	± 0.025	± 0.005	± 0.025
C	± 0.025	± 0.013	± 0.025
E	± 0.025	± 0.025	± 0.025
F	± 0.013	± 0.005	± 0.025
G	± 0.025	± 0.025	± 0.130
H	± 0.013	± 0.013	± 0.025
J	± 0.05-0.15	± 0.005	± 0.025
K	± 0.05-0.15	± 0.013	± 0.025
L	± 0.05-0.15	± 0.025	± 0.025
M	± 0.05-0.15	± 0.08-0.20	± 0.130
N	± 0.05-0.15	± 0.08-0.20	± 0.025
U	± 0.08-0.25	± 0.13-0.38	± 0.130

d : Daire Ölçüsü / Inscribed Circle
m : Şekle Göre / Refer to Figure
t : Kalınlık / Thickness

9 Kesme Kenar Uzunluğu / Cutting Edge Length

11 Köşe Konfigürasyonu / Corner Radius

01 r = 0.1
02 r = 0.2
04 r = 0.4
08 r = 0.8
12 r = 1.2
16 r = 1.6
24 r = 2.4

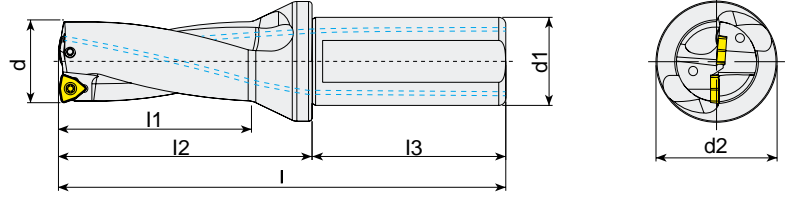

Delme Derinliği = 2xÇap
Drilling Depth = 2xDiameter

Takım Kodu Ordering Code	Stok Stock	Takım Ölçüleri (mm) Dimension (mm)							Kesici Uç Insert	Yedek Parçaları Spare Parts	
		d	d1	d2	l	l1	l2	l3		Sıkma Vidası Screw	Tork Anahtar Torx Key
ATUM 16XD2 WCM. 030208	●	16	25	34	110	32	54	56	WCM. 030208	3008-M2.5x6	80-T08
ATUM 16.5XD2 WCM. 030208	●	16.5	25	34	110	32	54	56			
ATUM 17XD2 WCM. 030208	●	17	25	34	112	34	56	56			
ATUM 17.5XD2 WCM. 030208	●	17.5	25	34	112	34	56	56			
ATUM 18XD2 WCM. 030208	●	18	25	34	114	36	58	56			
ATUM 18.5XD2 WCM. 030208	●	18.5	25	34	114	36	58	56			
ATUM 19XD2 WCM. 030208	●	19	25	34	116	38	60	56			
ATUM 19.5XD2 WCM. 030208	●	19.5	25	34	116	38	60	56			
ATUM 20XD2 WCM. 040208	●	20	25	34	118	40	62	56			
ATUM 20.5XD2 WCM. 040208	●	20.5	25	34	118	40	62	56			
ATUM 21XD2 WCM. 040208	●	21	25	34	120	42	64	56	WCM. 040208	3008-M2.5x6	80-T08
ATUM 21.5XD2 WCM. 040208	●	21.5	25	34	120	42	64	56			
ATUM 22XD2 WCM. 040208	●	22	25	34	122	44	66	56			
ATUM 22.5XD2 WCM. 040208	●	22.5	25	34	122	44	66	56			
ATUM 23XD2 WCM. 040208	●	23	25	34	124	46	68	56			
ATUM 23.5XD2 WCM. 040208	●	23.5	25	34	124	46	68	56			
ATUM 24XD2 WCM. 050308	●	24	25	34	126	48	70	56	WCM. 050308	1008-M3x8	
ATUM 24.5XD2 WCM. 050308	●	24.5	25	34	126	48	70	56			
ATUM 25XD2 WCM. 050308	●	25	25	34	128	50	72	56			
ATUM 25.5XD2 WCM. 050308	●	25.5	25	34	128	50	72	56			
ATUM 26XD2 WCM. 050308	●	26	25	34	130	52	74	56			
ATUM 26.5XD2 WCM. 050308	●	26.5	25	34	130	52	74	56			
ATUM 27XD2 WCM. 050308	●	27	25	34	132	54	76	56			
ATUM 27.5XD2 WCM. 050308	●	27.5	25	34	132	54	76	56			
ATUM 28XD2 WCM. 050308	●	28	25	34	134	56	78	56			
ATUM 28.5XD2 WCM. 050308	●	28.5	25	34	134	56	78	56			
ATUM 29XD2 WCM. 050308	●	29	25	34	136	58	80	56			
ATUM 29.5XD2 WCM. 050308	●	29.5	25	34	136	58	80	56			

R: Sağ/Right L: Sol/Left ● Stokta/In Stock ○ Stokta Yok/Non Stock Item
ISO Ucuna Uygundur. / Compatible with ISO Insert.

Sipariş Örneği/Ordering Example : 1 ad./pcs. ATUM 16xD2 WCM. 030208
Takma Uçlu Matkap Kullanım Kılavuzu : S 228 / User's Guide For U-Drills : P 228

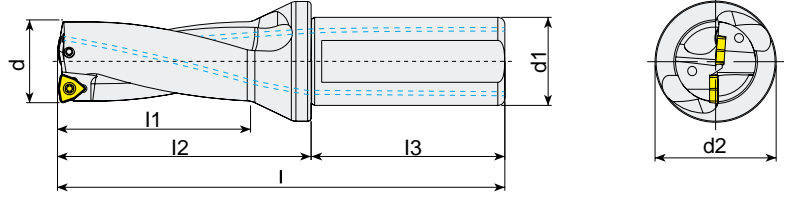

Delme Derinliği = 2xÇap
Drilling Depth = 2xDiameter

Takım Kodu Ordering Code	Stok Stock	Takım Ölçüleri (mm) Dimension (mm)							Kesici Uç Insert	Yedek Parçaları Spare Parts	
		d	d ₁	d ₂	l	l ₁	l ₂	l ₃		Sıkma Vidası Screw	Tork Anahtar Torx Key
ATUM 30XD2 WCM. 06T308	●	30	32	44	147	60	87	60	WCM. 06T308	1510-M3.5x9	80-T10
ATUM 31XD2 WCM. 06T308	●	31	32	44	149	62	89	60			
ATUM 32XD2 WCM. 06T308	●	32	32	44	151	64	91	60			
ATUM 33XD2 WCM. 06T308	●	33	32	44	153	66	93	60			
ATUM 34XD2 WCM. 06T308	●	34	32	44	155	68	95	60			
ATUM 35XD2 WCM. 06T308	●	35	32	44	157	70	97	60			
ATUM 36XD2 WCM. 06T308	●	36	32	44	159	72	99	60			
ATUM 37XD2 WCM. 06T308	●	37	32	44	161	74	101	60			
ATUM 38XD2 WCM. 06T308	●	38	32	44	163	76	103	60			
ATUM 39XD2 WCM. 06T308	●	39	32	44	165	78	105	60			
ATUM 40XD2 WCM. 06T308	●	40	32	44	167	80	107	60			
ATUM 41XD2 WCM. 06T308	●	41	32	44	169	82	109	60			
ATUM 42XD2 WCM. 06T308	●	42	32	44	171	84	111	60			
ATUM 43XD2 WCM. 06T308	●	43	32	44	173	86	113	60			
ATUM 44XD2 WCM. 06T308	●	44	32	44	175	88	115	60			
ATUM 45XD2 WCM. 080412	●	45	40	54	192	90	122	70			
ATUM 46XD2 WCM. 080412	●	46	40	54	194	92	124	70			
ATUM 47XD2 WCM. 080412	●	47	40	54	196	94	126	70			
ATUM 48XD2 WCM. 080412	●	48	40	54	198	96	128	70			
ATUM 49XD2 WCM. 080412	●	49	40	54	200	98	130	70			
ATUM 50XD2 WCM. 080412	●	50	40	54	202	100	132	70			
ATUM 51XD2 WCM. 080412	●	51	40	54	204	102	134	70			
ATUM 52XD2 WCM. 080412	●	52	40	54	206	104	136	70			
ATUM 53XD2 WCM. 080412	●	53	40	54	208	106	138	70			
ATUM 54XD2 WCM. 080412	●	54	40	54	210	108	140	70			
ATUM 55XD2 WCM. 080412	●	55	40	54	212	110	142	70			
ATUM 56XD2 WCM. 080412	●	56	40	64	214	112	144	70			
ATUM 57XD2 WCM. 080412	●	57	40	64	216	114	146	70			
ATUM 58XD2 WCM. 080412	●	58	40	64	218	116	148	70			
ATUM 59XD2 WCM. 080412	●	59	40	64	220	118	150	70			
ATUM 60XD2 WCM. 080412	●	60	40	64	222	120	152	70			

R: Sağ/Right L: Sol/Left ● Stokta/In Stock ○ Stokta Yok/Non Stock Item
ISO Ucuna Uygundur. / Compatible with ISO Insert.

Sipariş Örneği/Ordering Example : 1 ad./pcs. ATUM 30xD2 WCM. 06T308
Takma Uçlu Matkap Kullanım Kılavuzu : S 228 / User's Guide For U-Drills : P 228



Delme Derinliği = 3xÇap
Drilling Depth = 3xDiameter

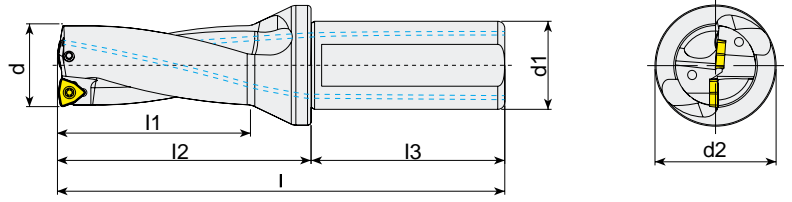

Takım Kodu Ordering Code	Stok Stock	Takım Ölçüleri (mm) Dimension (mm)							Kesici Uç Insert	Yedek Parçaları Spare Parts	
		d	d ₁	d ₂	l	l ₁	l ₂	l ₃		Sıkma Vidası Screw	Tork Anahtar Torx Key
ATUM 16XD3 WCM. 030208	●	16	25	34	126	48	70	56	WCM. 030208	3008-M2.5x6	80-T08
ATUM 16.5XD3 WCM. 030208	●	16.5	25	34	126	48	70	56			
ATUM 17XD3 WCM. 030208	●	17	25	34	129	51	73	56			
ATUM 17.5XD3 WCM. 030208	●	17.5	25	34	129	51	73	56			
ATUM 18XD3 WCM. 030208	●	18	25	34	132	54	76	56			
ATUM 18.5XD3 WCM. 030208	●	18.5	25	34	132	54	76	56			
ATUM 19XD3 WCM. 030208	●	19	25	34	135	57	79	56			
ATUM 19.5XD3 WCM. 030208	●	19.5	25	34	135	57	79	56			
ATUM 20XD3 WCM. 040208	●	20	25	34	138	60	82	56			
ATUM 20.5XD3 WCM. 040208	●	20.5	25	34	138	60	82	56			
ATUM 21XD3 WCM. 040208	●	21	25	34	141	63	85	56			
ATUM 21.5XD3 WCM. 040208	●	21.5	25	34	141	63	85	56			
ATUM 22XD3 WCM. 040208	●	22	25	34	144	66	88	56			
ATUM 22.5XD3 WCM. 040208	●	22.5	25	34	144	66	88	56			
ATUM 23XD3 WCM. 040208	●	23	25	34	147	69	91	56			
ATUM 23.5XD3 WCM. 040208	●	23.5	25	34	147	69	91	56			
ATUM 24XD3 WCM. 050308	●	24	25	34	150	72	94	56	WCM. 050308	1008-M3x8	80-T08
ATUM 24.5XD3 WCM. 050308	●	24.5	25	34	150	72	94	56			
ATUM 25XD3 WCM. 050308	●	25	25	34	153	75	97	56			
ATUM 25.5XD3 WCM. 050308	●	25.5	25	34	153	75	97	56			
ATUM 26XD3 WCM. 050308	●	26	25	34	156	78	100	56			
ATUM 26.5XD3 WCM. 050308	●	26.5	25	34	156	78	100	56			
ATUM 27XD3 WCM. 050308	●	27	25	34	159	81	103	56			
ATUM 27.5XD3 WCM. 050308	●	27.5	25	34	159	81	103	56			
ATUM 28XD3 WCM. 050308	●	28	25	34	162	84	106	56			
ATUM 28.5XD3 WCM. 050308	●	28.5	25	34	162	84	106	56			
ATUM 29XD3 WCM. 050308	●	29	25	34	165	87	109	56	WCM. 06T308	1510-M3.5x9	80-T10
ATUM 29.5XD3 WCM. 050308	●	29.5	25	34	165	87	109	56			
ATUM 30XD3 WCM. 06T308	●	30	32	44	177	90	117	60			
ATUM 30.5XD3 WCM. 06T308	●	30.5	32	44	177	90	117	60			
ATUM 31XD3 WCM. 06T308	●	31	32	44	180	93	120	60			
ATUM 31.5XD3 WCM. 06T308	●	31.5	32	44	180	93	120	60			
ATUM 32XD3 WCM. 06T308	●	32	32	44	183	96	123	60			
ATUM 32.5XD3 WCM. 06T308	●	32.5	32	44	183	96	123	60			
ATUM 33XD3 WCM. 06T308	●	33	32	44	186	99	126	60			
ATUM 33.5XD3 WCM. 06T308	●	33.5	32	44	186	99	126	60			
ATUM 34XD3 WCM. 06T308	●	34	32	44	189	102	129	60			
ATUM 34.5XD3 WCM. 06T308	●	34.5	32	44	189	102	129	60			

R: Sağ/Right L: Sol/Left ● Stokta/In Stock ○ Stokta Yok/Non Stock Item
ISO Ucuna Uygundur. / Compatiple with ISO Insert.

Sipariş Örneği/Ordering Example : 1 ad./pcs. ATUM 16xD3 WCM. 030208
Takma Uçlu Matkap Kullanım Kılavuzu : S 228 / User's Guide For U-Drills : P 228

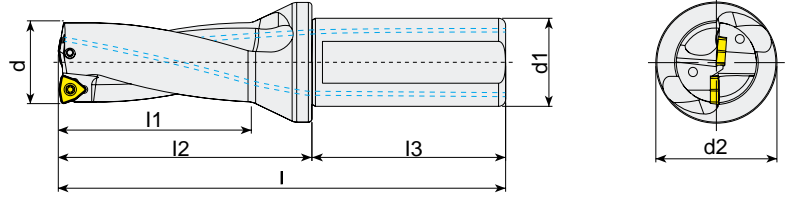

Delme Derinliği = 3xÇap
Drilling Depth = 3xDiameter

Takım Kodu Ordering Code	Stok Stock	Takım Ölçüleri (mm) Dimension (mm)							Kesici Uç Insert	Yedek Parçaları Spare Parts	
		d	d ₁	d ₂	l	l ₁	l ₂	l ₃		Sıkma Vidası Screw	Tork Anahtar Torx Key
ATUM 35XD3 WCM. 06T308	●	35	32	44	192	105	132	60	WCM. 06T308	1510-M3.5x9	80-T10
ATUM 35.5XD3 WCM. 06T308	●	35.5	32	44	192	105	132	60			
ATUM 36XD3 WCM. 06T308	●	36	32	44	195	108	135	60			
ATUM 36.5XD3 WCM. 06T308	●	36.5	32	44	195	108	135	60			
ATUM 37XD3 WCM. 06T308	●	37	32	44	198	111	138	60			
ATUM 37.5XD3 WCM. 06T308	●	37.5	32	44	198	111	138	60			
ATUM 38XD3 WCM. 06T308	●	38	32	44	201	114	141	60			
ATUM 38.5XD3 WCM. 06T308	●	38.5	32	44	201	114	141	60			
ATUM 39XD3 WCM. 06T308	●	39	32	44	204	117	144	60			
ATUM 39.5XD3 WCM. 06T308	●	39.5	32	44	204	117	144	60			
ATUM 40XD3 WCM. 06T308	●	40	32	44	207	120	147	60			
ATUM 40.5XD3 WCM. 06T308	●	40.5	32	44	207	120	147	60			
ATUM 41XD3 WCM. 06T308	●	41	32	44	210	123	150	60			
ATUM 41.5XD3 WCM. 06T308	●	41.5	32	44	210	123	150	60			
ATUM 42XD3 WCM. 06T308	●	42	32	44	213	126	153	60			
ATUM 42.5XD3 WCM. 06T308	●	42.5	32	44	213	126	153	60			
ATUM 43XD3 WCM. 06T308	●	43	32	44	216	129	156	60			
ATUM 43.5XD3 WCM. 06T308	●	43.5	32	44	216	129	156	60			
ATUM 44XD3 WCM. 06T308	●	44	32	44	219	132	159	60			
ATUM 44.5XD3 WCM. 06T308	●	44.5	32	44	219	132	159	60			
ATUM 45XD3 WCM. 080412	●	45	40	54	237	135	167	70	WCM. 080412	1515-M4x11	80-T15
ATUM 45.5XD3 WCM. 080412	●	45.5	40	54	237	135	167	70			
ATUM 46XD3 WCM. 080412	●	46	40	54	240	138	170	70			
ATUM 47XD3 WCM. 080412	●	47	40	54	243	141	173	70			
ATUM 48XD3 WCM. 080412	●	48	40	54	246	144	176	70			
ATUM 49XD3 WCM. 080412	●	49	40	54	249	147	179	70			
ATUM 50XD3 WCM. 080412	●	50	40	54	252	150	182	70			
ATUM 51XD3 WCM. 080412	●	51	40	54	255	153	185	70			
ATUM 52XD3 WCM. 080412	●	52	40	54	258	156	188	70			
ATUM 53XD3 WCM. 080412	●	53	40	54	261	159	191	70			
ATUM 54XD3 WCM. 080412	●	54	40	54	264	162	194	70			
ATUM 55XD3 WCM. 080412	●	55	40	54	267	165	197	70			
ATUM 56XD3 WCM. 080412	●	56	40	64	270	168	200	70			
ATUM 57XD3 WCM. 080412	●	57	40	64	273	171	203	70			
ATUM 58XD3 WCM. 080412	●	58	40	64	276	174	206	70			
ATUM 59XD3 WCM. 080412	●	59	40	64	279	177	209	70			
ATUM 60XD3 WCM. 080412	●	60	40	64	282	180	212	70			







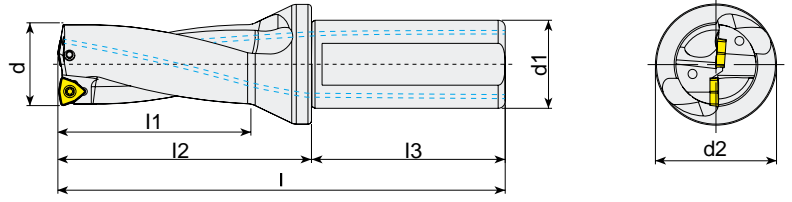

R: Sağ/Right L: Sol/Left ● Stokta/In Stock ○ Stokta Yok/Non Stock Item
ISO Ucuna Uygunudur. / Compatible with ISO Insert.

Sipariş Örneği/Ordering Example : 1 ad./pcs. ATUM 35xD3 WCM. 06T308
Takma Uçlu Matkap Kullanım Kılavuzu : S 228 / User's Guide For U-Drills : P 228

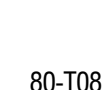

Delme Derinliği = 4xÇap
Drilling Depth = 4xDiameter



Takım Kodu Ordering Code	Stok Stock	Takım Ölçüleri (mm) Dimension (mm)							Kesici Uç Insert	Yedek Parçaları Spare Parts	
		d	d ₁	d ₂	l	l ₁	l ₂	l ₃		Sıkma Vidası Screw	Tork Anahtar Torx Key
ATUM 16XD4 WCM. 030208	●	16	25	34	142	64	86	56			
ATUM 16.5XD4 WCM. 030208	○	16.5	25	34	142	64	86	56			
ATUM 17XD4 WCM. 030208	●	17	25	34	146	68	90	56			
ATUM 17.5XD4 WCM. 030208	○	17.5	25	34	146	68	90	56			
ATUM 18XD4 WCM. 030208	●	18	25	34	150	72	94	56			
ATUM 18.5XD4 WCM. 030208	○	18.5	25	34	150	72	94	56			
ATUM 19XD4 WCM. 030208	●	19	25	34	154	76	98	56			
ATUM 19.5XD4 WCM. 030208	○	19.5	25	34	154	76	98	56			
ATUM 20XD4 WCM. 040208	●	20	25	34	158	80	102	56			
ATUM 20.5XD4 WCM. 040208	○	20.5	25	34	158	80	102	56			
ATUM 21XD4 WCM. 040208	●	21	25	34	162	84	106	56			
ATUM 21.5XD4 WCM. 040208	○	21.5	25	34	162	84	106	56			
ATUM 22XD4 WCM. 040208	●	22	25	34	166	88	110	56			
ATUM 22.5XD4 WCM. 040208	○	22.5	25	34	166	88	110	56			
ATUM 23XD4 WCM. 040208	●	23	25	34	170	92	114	56			
ATUM 23.5XD4 WCM. 040208	○	23.5	25	34	170	92	114	56			
ATUM 24XD4 WCM. 050308	●	24	25	34	174	96	118	56			
ATUM 24.5XD4 WCM. 050308	○	24.5	25	34	174	96	118	56			
ATUM 25XD4 WCM. 050308	●	25	25	34	178	100	122	56			
ATUM 25.5XD4 WCM. 050308	○	25.5	25	34	178	100	122	56			
ATUM 26XD4 WCM. 050308	●	26	25	34	182	104	126	56			
ATUM 26.5XD4 WCM. 050308	○	26.5	25	34	182	104	126	56			
ATUM 27XD4 WCM. 050308	●	27	25	34	186	108	130	56			
ATUM 27.5XD4 WCM. 050308	○	27.5	25	34	186	108	130	56			
ATUM 28XD4 WCM. 050308	●	28	25	34	190	112	134	56			
ATUM 28.5XD4 WCM. 050308	○	28.5	25	34	190	112	134	56			
ATUM 29XD4 WCM. 050308	●	29	25	34	194	116	138	56			
ATUM 29.5XD4 WCM. 050308	○	29.5	25	34	194	116	138	56			

R: Sağ/Right L: Sol/Left ● Stokta/In Stock ○ Stokta Yok/Non Stock Item
ISO Ucuna Uygunudur. / Compatible with ISO Insert.

Sipariş Örneği/Ordering Example : 1 ad./pcs. ATUM 16xD4 WCM. 030208
Takma Uçlu Matkap Kullanım Kılavuzu : S 228 / User's Guide For U-Drills : P 228



Delme Derinliği = 4xÇap
Drilling Depth = 4xDiameter

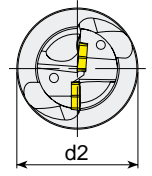
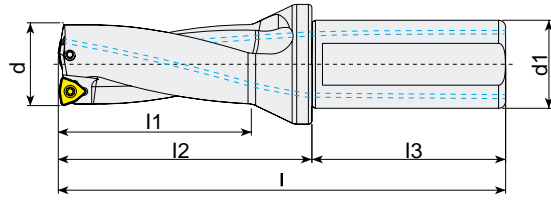

Takım Kodu Ordering Code	Stok Stock	Takım Ölçüleri (mm) Dimension (mm)							Kesici Uç Insert	Yedek Parçaları Spare Parts	
		d	d ₁	d ₂	l	l ₁	l ₂	l ₃		Sıkma Vidası Screw	Tork Anahtar Torx Key
ATUM 30XD4 WCM. 06T308	●	30	32	44	207	120	147	60	WCM. 06T308	1510-M3.5x9	80-T10
ATUM 31XD4 WCM. 06T308	●	31	32	44	211	124	151	60			
ATUM 32XD4 WCM. 06T308	●	32	32	44	215	128	155	60			
ATUM 33XD4 WCM. 06T308	●	33	32	44	219	132	159	60			
ATUM 33.5XD4 WCM. 06T308	●	33.5	32	44	219	132	159	60			
ATUM 34XD4 WCM. 06T308	●	34	32	44	223	136	163	60			
ATUM 35XD4 WCM. 06T308	●	35	32	44	227	140	167	60			
ATUM 36XD4 WCM. 06T308	●	36	32	44	231	144	171	60			
ATUM 37XD4 WCM. 06T308	●	37	32	44	235	148	175	60			
ATUM 38XD4 WCM. 06T308	●	38	32	44	239	152	179	60			
ATUM 38.5XD4 WCM. 06T308	●	38.5	32	44	239	152	179	60			
ATUM 39XD4 WCM. 06T308	●	39	32	44	243	156	183	60			
ATUM 40XD4 WCM. 06T308	●	40	32	44	247	160	187	60			
ATUM 41XD4 WCM. 06T308	●	41	32	44	251	164	191	60			
ATUM 42XD4 WCM. 06T308	●	42	32	44	255	168	195	60			
ATUM 43XD4 WCM. 06T308	●	43	32	44	259	172	199	60			
ATUM 44XD4 WCM. 06T308	●	44	32	44	263	176	203	60			
ATUM 45XD4 WCM. 080412	●	45	40	54	282	180	212	70	WCM. 080412	1515-M4x11	80-T15
ATUM 46XD4 WCM. 080412	●	46	40	54	286	184	216	70			
ATUM 47XD4 WCM. 080412	●	47	40	54	290	188	220	70			
ATUM 48XD4 WCM. 080412	●	48	40	54	294	192	224	70			
ATUM 49XD4 WCM. 080412	●	49	40	54	298	196	228	70			
ATUM 50XD4 WCM. 080412	●	50	40	54	302	200	232	70			

R: Sağ/Right L: Sol/Left ● Stokta/In Stock ○ Stokta Yok/Non Stock Item
ISO Ucuna Uygunudur. / Compatible with ISO Insert.

Sipariş Örneği/Ordering Example : 1 ad./pcs. ATUM 30xD4 WCM. 06T308
Takma Uçlu Matkap Kullanım Kılavuzu : S 228 / User's Guide For U-Drills : P 228





Delme Derinliği = 2xÇap
Drilling Depth = 2xDiameter

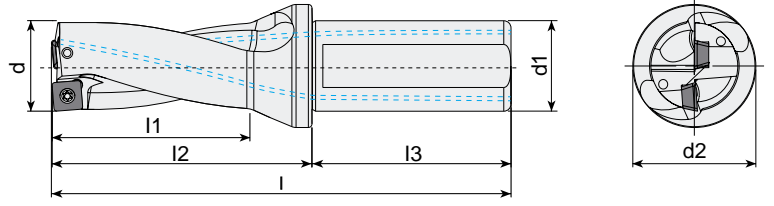

Takım Kodu Ordering Code	Stok Stock	Takım Ölçüleri (mm) Dimension (mm)							Kesici Uç Insert	Yedek Parçaları Spare Parts	
		d	d1	d2	l	l1	l2	l3		Sıkma Vidası Screw	Tork Anahtar Torx Key
ATUM 12.5XD2 SP.. 050204	●	12.5	20	25	96	24	46	50	SP.. 050204	3006-M2x4	80-T06
ATUM 13XD2 SP.. 050204	●	13	20	25	98	26	48	50			
ATUM 13.5XD2 SP.. 050204	●	13.5	20	25	98	26	48	50			
ATUM 14XD2 SP.. 050204	●	14	20	25	100	28	50	50			
ATUM 14.5XD2 SP.. 050204	●	14.5	20	25	100	28	50	50			
ATUM 15XD2 SP.. 050204	●	15	20	25	102	30	52	50	SP.. 060204	3007-M2.2x5	80-T07
ATUM 15.5XD2 SP.. 060204	●	15.5	20	25	102	30	52	50			
ATUM 16XD2 SP.. 060204	●	16	25	34	110	32	54	56			
ATUM 16.5XD2 SP.. 060204	●	16.5	25	34	110	32	54	56			
ATUM 17XD2 SP.. 060204	●	17	25	34	112	34	56	56			
ATUM 17.5XD2 SP.. 060204	●	17.5	25	34	112	34	56	56			
ATUM 18XD2 SP.. 060204	●	18	25	34	114	36	58	56			
ATUM 18.5D2 SP.. 060204	●	18.5	25	34	114	36	58	56			
ATUM 19XD2 SP.. 060204	●	19	25	34	116	38	60	56			
ATUM 19.5XD2 SP.. 060204	●	19.5	25	34	116	38	60	56			
ATUM 20XD2 SP.. 060204	●	20	25	34	118	40	62	56	SP.. 07T308	3008-M2.5x6	80-T08
ATUM 20.5XD2 SP.. 060204	●	20.5	25	34	118	40	62	56			
ATUM 21XD2 SP.. 060204	●	21	25	34	120	42	64	56			
ATUM 21.5XD2 SP.. 060204	●	21.5	25	34	120	42	64	56			
ATUM 22XD2 SP.. 07T308	●	22	25	34	122	44	66	56			
ATUM 22.5XD2 SP.. 07T308	●	22.5	25	34	122	44	66	56			
ATUM 23XD2 SP.. 07T308	●	23	25	34	124	46	68	56			
ATUM 23.5XD2 SP.. 07T308	●	23.5	25	34	124	46	68	56			
ATUM 24XD2 SP.. 07T308	●	24	25	34	126	48	70	56			
ATUM 24.5XD2 SP.. 07T308	●	24.5	25	34	126	48	70	56			
ATUM 25XD2 SP.. 07T308	●	25	25	34	128	50	72	56			
ATUM 25.5XD2 SP.. 07T308	●	25.5	25	34	128	50	72	56			
ATUM 26XD2 SP.. 07T308	●	26	25	34	130	52	74	56			
ATUM 26.5XD2 SP.. 07T308	●	26.5	25	34	130	52	74	56			
ATUM 27XD2 SP.. 07T308	●	27	25	34	132	54	76	56			
ATUM 27.5XD2 SP.. 07T308	●	27.5	25	34	132	54	76	56			

R: Sağ/Right L: Sol/Left ● Stokta/In Stock ○ Stokta Yok/Non Stock Item
TGTC Ucuna Uygundur. / Compatible with TGTC Insert.

Sipariş Örneği/Ordering Example : 1 ad./pcs. ATUM 12.5xD2 SP.. 050204
Takma Uçlu Matkap Kullanım Kılavuzu : S 228 / User's Guide For U-Drills : P 228



Delme Derinliği = 2xÇap
Drilling Depth = 2xDiameter

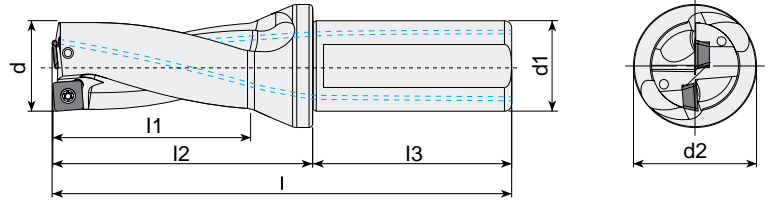

Takım Kodu Ordering Code	Stok Stock	Takım Ölçüleri (mm) Dimension (mm)							Kesici Uç Insert	Yedek Parçaları Spare Parts	
		d	d ₁	d ₂	l	l ₁	l ₂	l ₃		Sıkma Vidası Screw	Tork Anahtar Torx Key
ATUM 28XD2 SP.. 090408	●	28	25	34	134	56	78	56	SP.. 090408	4015-M3.5x9	80-T15
ATUM 28.5XD2 SP.. 090408	●	28.5	25	34	134	56	78	56			
ATUM 29XD2 SP.. 090408	●	29	25	34	136	58	80	56			
ATUM 29.5XD2 SP.. 090408	●	29.5	25	34	136	58	80	56			
ATUM 30XD2 SP.. 090408	●	30	32	44	147	60	87	60			
ATUM 31XD2 SP.. 090408	●	31	32	44	149	62	89	60			
ATUM 32XD2 SP.. 090408	●	32	32	44	151	64	91	60			
ATUM 33XD2 SP.. 090408	●	33	32	44	153	66	93	60			
ATUM 34XD2 SP.. 110408	●	34	32	44	155	68	95	60	SP.. 110408	1515-M4x11	80-T15
ATUM 35XD2 SP.. 110408	●	35	32	44	157	70	97	60			
ATUM 36XD2 SP.. 110408	●	36	32	44	159	72	99	60			
ATUM 37XD2 SP.. 110408	●	37	32	44	161	74	101	60			
ATUM 38XD2 SP.. 110408	●	38	32	44	163	76	103	60			
ATUM 39XD2 SP.. 110408	●	39	32	44	165	78	105	60			
ATUM 40XD2 SP.. 110408	●	40	32	44	167	80	107	60			
ATUM 41XD2 SP.. 110408	●	41	32	44	169	82	109	60			
ATUM 42XD2 SP.. 140512	●	42	32	44	171	84	111	60	SP.. 140512	1020-M5x11	80-T20
ATUM 43XD2 SP.. 140512	●	43	32	44	173	86	113	60			
ATUM 44XD2 SP.. 140512	●	44	32	44	175	88	115	60			
ATUM 45XD2 SP.. 140512	●	45	40	54	192	90	122	70			
ATUM 46XD2 SP.. 140512	●	46	40	54	194	92	124	70			
ATUM 47XD2 SP.. 140512	●	47	40	54	196	94	126	70			
ATUM 48XD2 SP.. 140512	●	48	40	54	198	96	128	70			
ATUM 49XD2 SP.. 140512	●	49	40	54	200	98	130	70			
ATUM 50XD2 SP.. 140512	●	50	40	54	202	100	132	70			

R: Sağ/Right L: Sol/Left ● Stokta/In Stock ○ Stokta Yok/Non Stock Item
TGTC Ucuna Uygundur. / Compatible with TGTC Insert.

Sipariş Örneği/Ordering Example : 1 ad./pcs. ATUM 28XD2 SP.. 090408
Takma Uçlu Matkap Kullanım Kılavuzu : S 228 / User's Guide For U-Drills : P 228



Delme Derinliği = 3xÇap
Drilling Depth = 3xDiameter

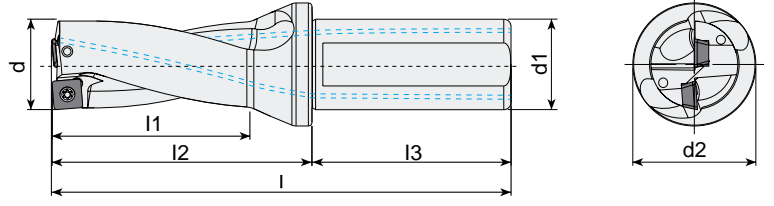

Takım Kodu Ordering Code	Stok Stock	Takım Ölçüleri (mm) Dimension (mm)							Kesici Uç Insert	Yedek Parçaları Spare Parts	
		d	d1	d2	l	l1	l2	l3		Sıkma Vidası Screw	Tork Anahtar Torx Key
ATUM 12.5XD3 SP.. 050204	●	12.5	20	25	108	36	58	50	SP.. 050204	3006-M2x4	80-T06
ATUM 13XD3 SP.. 050204	●	13	20	25	111	39	61	50			
ATUM 13.5XD3 SP.. 050204	●	13.5	20	25	111	39	61	50			
ATUM 14XD3 SP.. 050204	●	14	20	25	114	42	64	50			
ATUM 14.5XD3 SP.. 050204	●	14.5	20	25	114	42	64	50			
ATUM 15XD3 SP.. 050204	●	15	20	25	117	45	67	50			
ATUM 15.5XD3 SP.. 060204	●	15.5	20	25	117	45	67	50	SP.. 060204	3007-M2.2x5	80-T07
ATUM 16XD3 SP.. 060204	●	16	25	34	126	48	70	56			
ATUM 16.5XD3 SP.. 060204	●	16.5	25	34	126	48	70	56			
ATUM 17XD3 SP.. 060204	●	17	25	34	129	51	73	56			
ATUM 17.5XD3 SP.. 060204	●	17.5	25	34	129	51	73	56			
ATUM 18XD3 SP.. 060204	●	18	25	34	132	54	76	56			
ATUM 18.5XD3 SP.. 060204	●	18.5	25	34	132	54	76	56			
ATUM 19XD3 SP.. 060204	●	19	25	34	135	57	79	56			
ATUM 19.5XD3 SP.. 060204	●	19.5	25	34	135	57	79	56			
ATUM 20XD3 SP.. 060204	●	20	25	34	138	60	82	56			
ATUM 20.5XD3 SP.. 060204	●	20.5	25	34	138	60	82	56			
ATUM 21XD3 SP.. 060204	●	21	25	34	141	63	85	56			
ATUM 21.5XD3 SP.. 060204	●	21.5	25	34	141	63	85	56			
ATUM 22XD3 SP.. 07T308	●	22	25	34	144	66	88	56			
ATUM 22.5XD3 SP.. 07T308	●	22.5	25	34	144	66	88	56			
ATUM 23XD3 SP.. 07T308	●	23	25	34	147	69	91	56			
ATUM 23.5XD3 SP.. 07T308	●	23.5	25	34	147	69	91	56			
ATUM 24XD3 SP.. 07T308	●	24	25	34	150	72	94	56			
ATUM 24.5XD3 SP.. 07T308	●	24.5	25	34	150	72	94	56			
ATUM 25XD3 SP.. 07T308	●	25	25	34	153	75	97	56			
ATUM 25.5XD3 SP.. 07T308	●	25.5	25	34	153	75	97	56			
ATUM 26XD3 SP.. 07T308	●	26	25	34	156	78	100	56	SP.. 090408	4015-M3.5x9	80-T15
ATUM 26.5XD3 SP.. 07T308	●	26.5	25	34	156	78	100	56			
ATUM 27XD3 SP.. 07T308	●	27	25	34	159	81	103	56			
ATUM 27.5XD3 SP.. 07T308	●	27.5	25	34	159	81	103	56			
ATUM 28XD3 SP.. 090408	●	28	25	34	162	84	106	56			
ATUM 28.5XD3 SP.. 090408	●	28.5	25	34	162	84	106	56			
ATUM 29XD3 SP.. 090408	●	29	25	34	165	87	109	56			
ATUM 29.5XD3 SP.. 090408	●	29.5	25	34	165	87	109	56			
ATUM 30XD3 SP.. 090408	●	30	32	44	177	90	117	60			
ATUM 30.5XD3 SP.. 090408	●	30.5	32	44	177	90	117	60			
ATUM 31XD3 SP.. 090408	●	31	32	44	180	93	120	60			
ATUM 31.5XD3 SP.. 090408	●	31.5	32	44	180	93	120	60			
ATUM 32XD3 SP.. 090408	●	32	32	44	183	96	123	60			
ATUM 32.5XD3 SP.. 090408	●	32.5	32	44	183	96	123	60			
ATUM 33XD3 SP.. 090408	●	33	32	44	186	99	126	60			
ATUM 33.5XD3 SP.. 090408	●	33.5	32	44	186	99	126	60			

R: Sağ/Right L: Sol/Left ● Stokta/In Stock ○ Stokta Yok/Non Stock Item
TGTC Ucuna Uygunudur. / Compatible with TGTC Insert.

Sipariş Örneği/Ordering Example : 1 ad./pcs. ATUM 12.5XD3 SP.. 050204
Takma Uçlu Matkap Kullanım Kılavuzu : S 228 / User's Guide For U-Drills : P 228



Delme Derinliği = 3xÇap
Drilling Depth = 3xDiameter

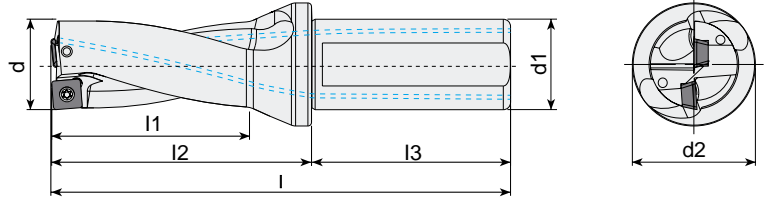

Takım Kodu Ordering Code	Stok Stock	Takım Ölçüleri (mm) Dimension (mm)							Kesici Uç Insert	Yedek Parçaları Spare Parts				
		d	d ₁	d ₂	l	l ₁	l ₂	l ₃		Sıkma Vidası Screw	Tork Anahtar Torx Key			
ATUM 34XD3 SP.. 110408	●	34	32	44	189	102	129	60	SP.. 110408	1515-M4x11	80-T15			
ATUM 34.5XD3 SP.. 110408	●	34.5	32	44	189	102	129	60						
ATUM 35XD3 SP.. 110408	●	35	32	44	192	105	132	60						
ATUM 35.5XD3 SP.. 110408	●	35.5	32	44	192	105	132	60						
ATUM 36XD3 SP.. 110408	●	36	32	44	195	108	135	60						
ATUM 36.5XD3 SP.. 110408	●	36.5	32	44	195	108	135	60						
ATUM 37XD3 SP.. 110408	●	37	32	44	198	111	138	60						
ATUM 37.5XD3 SP.. 110408	●	37.5	32	44	198	111	138	60						
ATUM 38XD3 SP.. 110408	●	38	32	44	201	114	141	60						
ATUM 38.5XD3 SP.. 110408	●	38.5	32	44	201	114	141	60						
ATUM 39XD3 SP.. 110408	●	39	32	44	204	117	144	60						
ATUM 39.5XD3 SP.. 110408	●	39.5	32	44	204	117	144	60						
ATUM 40XD3 SP.. 110408	●	40	32	44	207	120	147	60						
ATUM 40.5XD3 SP.. 110408	●	40.5	32	44	207	120	147	60						
ATUM 41XD3 SP.. 110408	●	41	32	44	210	123	150	60						
ATUM 41.5XD3 SP.. 110408	●	41.5	32	44	210	123	150	60						
ATUM 42XD3 SP.. 140512	●	42	32	44	213	126	153	60				SP.. 140512	1020-M5x11	80-T20
ATUM 42.5XD3 SP.. 140512	●	42.5	32	44	213	126	153	60						
ATUM 43XD3 SP.. 140512	●	43	32	44	216	129	156	60						
ATUM 43.5XD3 SP.. 140512	●	43.5	32	44	216	129	156	60						
ATUM 44XD3 SP.. 140512	●	44	32	44	219	132	159	60						
ATUM 44.5XD3 SP.. 140512	●	44.5	32	44	219	132	159	60						
ATUM 45XD3 SP.. 140512	●	45	40	54	237	135	167	70						
ATUM 45.5XD3 SP.. 140512	●	45.5	40	54	237	135	167	70						
ATUM 46XD3 SP.. 140512	●	46	40	54	240	138	170	70						
ATUM 47XD3 SP.. 140512	●	47	40	54	243	141	173	70						
ATUM 48XD3 SP.. 140512	●	48	40	54	246	144	176	70						
ATUM 49XD3 SP.. 140512	●	49	40	54	249	147	179	70						
ATUM 50XD3 SP.. 140512	●	50	40	54	252	150	182	70						
ATUM 51XD3 SP.. 140512	●	51	40	54	255	153	185	70						
ATUM 52XD3 SP.. 140512	●	52	40	54	258	156	188	70						
ATUM 53XD3 SP.. 140512	●	53	40	54	261	159	191	70						
ATUM 54XD3 SP.. 140512	●	54	40	54	264	162	194	70						

R: Sağ/Right L: Sol/Left ● Stokta/In Stock ○ Stokta Yok/Non Stock Item
TGTC Ucuna Uygundur. / Compatiple with TGTC Insert.

Sipariş Örneği/Ordering Example : 1 ad./pcs. ATUM 34xD3 SP.. 110408
Takma Uçlu Matkap Kullanım Kılavuzu : S 228 / User's Guide For U-Drills : P 228



Delme Derinliği = 4xÇap
Drilling Depth = 4xDiameter

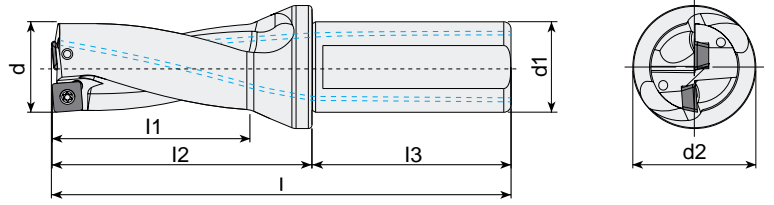

Takım Kodu Ordering Code	Stok Stock	Takım Ölçüleri (mm) Dimension (mm)							Kesici Uç Insert	Yedek Parçaları Spare Parts	
		d	d1	d2	l	l1	l2	l3		Sıkma Vidası Screw	Tork Anahtar Torx Key
ATUM 13XD4 SP.. 050204	●	13	20	25	124	52	74	50	SP.. 050204	3006-M2x4	80-T06
ATUM 14XD4 SP.. 050204	●	14	20	25	128	56	78	50			
ATUM 15XD4 SP.. 050204	●	15	20	25	132	60	82	50			
ATUM 16XD4 SP.. 060204	●	16	25	34	142	64	86	56	SP.. 060204	3007-M2.2x5	80-T07
ATUM 17XD4 SP.. 060204	●	17	25	34	146	68	90	56			
ATUM 17.5XD4 SP.. 060204	●	17	25	34	146	68	90	56			
ATUM 18XD4 SP.. 060204	●	18	25	34	150	72	94	56			
ATUM 19XD4 SP.. 060204	●	19	25	34	154	76	98	56			
ATUM 19.5XD4 SP.. 060204	●	19.5	25	34	154	76	98	56			
ATUM 20XD4 SP.. 060204	●	20	25	34	158	80	102	56			
ATUM 21XD4 SP.. 060204	●	21	25	34	162	84	106	56			
ATUM 22XD4 SP.. 07T308	●	22	25	34	166	88	110	56	SP.. 07T308	3008-M2.5x6	80-T08
ATUM 23XD4 SP.. 07T308	●	23	25	34	170	92	114	56			
ATUM 23.5XD4 SP.. 07T308	●	23.5	25	34	170	92	114	56			
ATUM 24XD4 SP.. 07T308	●	24	25	34	174	96	118	56			
ATUM 25XD4 SP.. 07T308	●	25	25	34	178	100	122	56			
ATUM 26XD4 SP.. 07T308	●	26	25	34	182	104	126	56			
ATUM 27XD4 SP.. 07T308	●	27	25	34	186	108	130	56			
ATUM 27.5XD4 SP.. 07T308	●	27.5	25	34	186	108	130	56			
ATUM 28XD4 SP.. 090408	●	28	25	34	190	112	134	56	SP.. 090408	4015-M3.5x9	80-T15
ATUM 29XD4 SP.. 090408	●	29	25	34	194	116	138	56			
ATUM 30XD4 SP.. 090408	●	30	32	44	207	120	147	60			
ATUM 31XD4 SP.. 090408	●	31	32	44	211	124	151	60			
ATUM 32XD4 SP.. 090408	●	32	32	44	215	128	155	60			
ATUM 33XD4 SP.. 090408	●	33	32	44	219	132	159	60			
ATUM 33.5XD4 SP.. 090408	●	33.5	32	44	219	132	159	60			
ATUM 34XD4 SP.. 110408	●	34	32	44	223	136	163	60			
ATUM 35XD4 SP.. 110408	●	35	32	44	227	140	167	60	SP.. 110408	1515-M4x11	80-T15
ATUM 36XD4 SP.. 110408	●	36	32	44	231	144	171	60			
ATUM 37XD4 SP.. 110408	●	37	32	44	235	148	175	60			
ATUM 38XD4 SP.. 110408	●	38	32	44	239	152	179	60			
ATUM 39XD4 SP.. 110408	●	39	32	44	243	156	183	60			
ATUM 40XD4 SP.. 110408	●	40	32	44	247	160	187	60			
ATUM 41XD4 SP.. 110408	●	41	32	44	251	164	191	60			
ATUM 42XD4 SP.. 140512	●	42	32	44	255	168	195	60	SP.. 140512	1020-M5x11	80-T20
ATUM 43XD4 SP.. 140512	●	43	32	44	259	172	199	60			
ATUM 44XD4 SP.. 140512	●	44	32	44	263	176	203	60			

R: Sağ/Right L: Sol/Left ● Stokta/In Stock ○ Stokta Yok/Non Stock Item
TGTC Ucuna Uygunudur. / Compatible with TGTC Insert.

Sipariş Örneği/Ordering Example : 1 ad./pcs. ATUM 13xD4 SP.. 050204
Takma Uçlu Matkap Kullanım Kılavuzu : S 228 / User's Guide For U-Drills : P 228



Delme Derinliği = 2xÇap
Drilling Depth = 2xDiameter

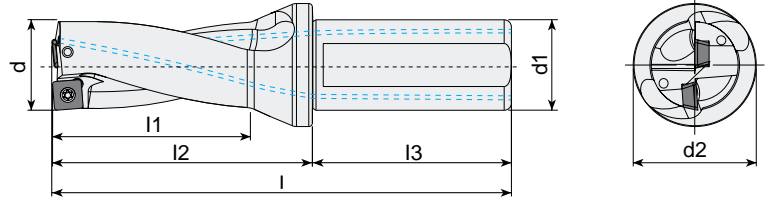

Takım Kodu Ordering Code	Stok Stock	Takım Ölçüleri (mm) Dimension (mm)							Kesici Uç Insert	Yedek Parçaları Spare Parts	
		d	d1	d2	l	l1	l2	l3		Sıkma Vidası Screw	Tork Anahtar Torx Key
ATUM 13XD2 SPGT 050204	●	13	20	25	124	26	48	50	SPGT 050204	3006-M2x4	80-T06
ATUM 14XD2 SPGT 050204	●	14	20	25	128	28	50	50			
ATUM 15XD2 SPGT 050204	●	15	20	25	132	30	52	50			
ATUM 16XD2 SPGT 060204	●	16	25	34	142	32	54	56			
ATUM 16.5XD2 SPGT 060204	●	16.5	25	34	142	32	54	56	SPGT 060204	3007-M2.2x5	80-T07
ATUM 17XD2 SPGT 060204	●	17	25	34	146	34	56	56			
ATUM 17.5XD2 SPGT 060204	●	17.5	25	34	146	34	56	56			
ATUM 18XD2 SPGT 060204	●	18	25	34	150	36	58	56			
ATUM 19XD2 SPGT 060204	●	19	25	34	154	38	60	56			
ATUM 20XD2 SPGT 060204	●	20	25	34	158	40	62	56			
ATUM 22XD2 SPGT 07T308	●	22	25	34	166	44	66	56	SPGT 07T308	3008-M2.5x6	80-T08
ATUM 22.5XD2 SPGT 07T308	●	22.5	25	34	166	44	66	56			
ATUM 23XD2 SPGT 07T308	●	23	25	34	170	46	68	56			
ATUM 24XD2 SPGT 07T308	●	24	25	34	174	48	70	56			
ATUM 25XD2 SPGT 07T308	●	25	25	34	178	50	72	56			
ATUM 26XD2 SPGT 07T308	●	26	25	34	182	52	74	56			
ATUM 28XD2 SPGT 090408	●	28	25	34	190	56	78	56	SPGT 090408	4015-M3.5x9	80-T15
ATUM 29XD2 SPGT 090408	●	29	25	34	194	58	80	56			
ATUM 30XD2 SPGT 090408	●	30	32	44	207	60	87	60			
ATUM 32XD2 SPGT 090408	●	32	32	44	215	64	91	60			
ATUM 35XD2 SPGT 110408	●	35	32	44	227	70	97	60	SPGT 110408	1515-M4x11	80-T15
ATUM 36XD2 SPGT 110408	●	36	32	44	231	72	99	60			
ATUM 40XD2 SPGT 110408	●	40	32	44	247	80	107	60			

R: Sağ/Right L: Sol/Left ● Stokta/In Stock ○ Stokta Yok/Non Stock Item
ZCC Ucuna Uygunudur. / Compatible with ZCC Insert.

Sipariş Örneği/Ordering Example : 1 ad./pcs. ATUM 13XD2 SPGT 050204
Takma Uçlu Matkap Kullanım Kılavuzu : S 228 / User's Guide For U-Drills : P 228





Delme Derinliği = 3xÇap
Drilling Depth = 3xDiameter

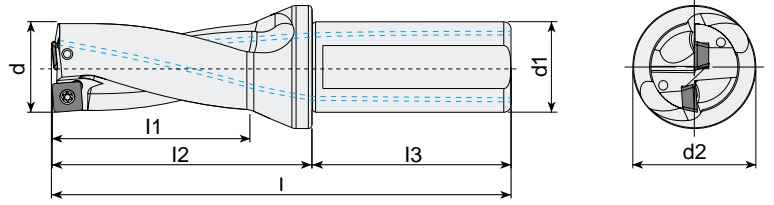

Takım Kodu Ordering Code	Stok Stock	Takım Ölçüleri (mm) Dimension (mm)							Kesici Uç Insert	Yedek Parçaları Spare Parts	
		d	d1	d2	l	l1	l2	l3		Sıkma Vidası Screw	Tork Anahtar Torx Key
ATUM 12.5XD3 SPGT 050204	●	12.5	20	25	144	36	58	50	SPGT 050204	3006-M2x4	80-T06
ATUM 13XD3 SPGT 050204	●	13	20	25	150	39	61	50			
ATUM 13.5XD3 SPGT 050204	●	13.5	20	25	150	39	61	50			
ATUM 14XD3 SPGT 050204	●	14	20	25	156	42	64	50			
ATUM 14.5XD3 SPGT 050204	●	14.5	20	25	156	42	64	50			
ATUM 15XD3 SPGT 050204	●	15	20	25	162	45	67	50			
ATUM 15.5XD3 SPGT 060204	●	15.5	20	25	162	45	67	50	SPGT 060204	3007-M2.2x5	80-T07
ATUM 16XD3 SPGT 060204	●	16	25	34	174	48	70	56			
ATUM 16.5XD3 SPGT 060204	●	16.5	25	34	174	48	70	56			
ATUM 17XD3 SPGT 060204	●	17	25	34	180	51	73	56			
ATUM 17.5XD3 SPGT 060204	●	17.5	25	34	180	51	73	56			
ATUM 18XD3 SPGT 060204	●	18	25	34	186	54	76	56			
ATUM 18.5XD3 SPGT 060204	●	18.5	25	34	186	54	76	56			
ATUM 19XD3 SPGT 060204	●	19	25	34	192	57	79	56			
ATUM 19.5XD3 SPGT 060204	●	19.5	25	34	192	57	79	56			
ATUM 20XD3 SPGT 060204	●	20	25	34	198	60	82	56			
ATUM 20.5XD3 SPGT 060204	●	20.5	25	34	198	60	82	56			
ATUM 21XD3 SPGT 060204	●	21	25	34	204	63	85	56			
ATUM 21.5XD3 SPGT 060204	●	21.5	25	34	204	63	85	56			
ATUM 22XD3 SPGT 07T308	●	22	25	34	210	66	88	56			
ATUM 22.5XD3 SPGT 07T308	●	22.5	25	34	210	66	88	56			
ATUM 23XD3 SPGT 07T308	●	23	25	34	216	69	91	56			
ATUM 23.5XD3 SPGT 07T308	●	23.5	25	34	216	69	91	56			
ATUM 24XD3 SPGT 07T308	●	24	25	34	222	72	94	56			
ATUM 24.5XD3 SPGT 07T308	●	24.5	25	34	222	72	94	56			
ATUM 25XD3 SPGT 07T308	●	25	25	34	228	75	97	56			
ATUM 25.5XD3 SPGT 07T308	●	25.5	25	34	228	75	97	56			
ATUM 26XD3 SPGT 07T308	●	26	25	34	234	78	100	56			
ATUM 26.5XD3 SPGT 07T308	●	26.5	25	34	234	78	100	56			
ATUM 27XD3 SPGT 07T308	●	27	25	34	240	81	103	56	SPGT 090408	4015-M3.5x9	80-T15
ATUM 27.5XD3 SPGT 07T308	●	27.5	25	34	240	81	103	56			
ATUM 28XD3 SPGT 090408	●	28	25	34	246	84	106	56			
ATUM 28.5XD3 SPGT 090408	●	28.5	25	34	246	84	106	56			
ATUM 29XD3 SPGT 090408	●	29	25	34	252	87	109	56			
ATUM 29.5XD3 SPGT 090408	●	29.5	25	34	252	87	109	56			
ATUM 30XD3 SPGT 090408	●	30	32	44	267	90	117	60			
ATUM 31XD3 SPGT 090408	●	31	32	44	273	93	120	60			
ATUM 32XD3 SPGT 090408	●	32	32	44	279	96	123	60			
ATUM 33XD3 SPGT 090408	●	33	32	44	285	99	126	60			

R: Sağ/Right L: Sol/Left ● Stokta/In Stock ○ Stokta Yok/Non Stock Item
ZCC Ucuna Uygundur. / Compatible with ZCC Insert.

Sipariş Örneği/Ordering Example : 1 ad./pcs. ATUM 12.5XD3 SPGT 050204
Takma Uçlu Matkap Kullanım Kılavuzu : S 228 / User's Guide For U-Drills : P 228



Delme Derinliği = 3xÇap
= 4xÇap
Drilling Depth = 3xDiameter
= 4xDiameter

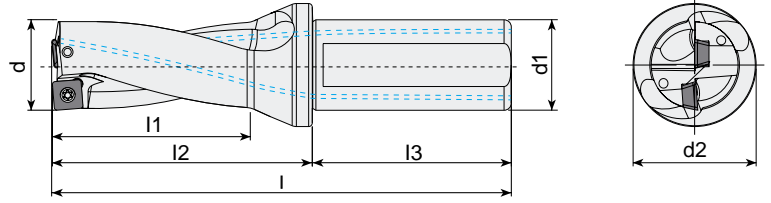

Takım Kodu Ordering Code	Stok Stock	Takım Ölçüleri (mm) Dimension (mm)							Kesici Uç Insert	Yedek Parçaları Spare Parts	
		d	d1	d2	l	l1	l2	l3		Sıkma Vidası Screw	Tork Anahtar Torx Key
ATUM 34XD3 SPGT 110408	●	34	32	44	291	102	129	60		1515-M4x11	
ATUM 35XD3 SPGT 110408	●	35	32	44	297	105	132	60			
ATUM 37XD3 SPGT 110408	●	37	32	44	309	111	138	60			
ATUM 38XD3 SPGT 110408	●	38	32	44	315	114	141	60			
ATUM 39XD3 SPGT 110408	●	39	32	44	321	117	144	60			
ATUM 40XD3 SPGT 110408	●	40	32	44	327	120	147	60		1020-M5x11	
ATUM 42XD3 SPGT 140512	●	42	32	44	339	126	153	60			
ATUM 43XD3 SPGT 140512	●	43	32	44	345	129	156	60			
ATUM 44XD3 SPGT 140512	●	44	32	44	351	132	159	60			
ATUM 49XD3 SPGT 140512	●	49	40	54	396	147	179	70			
ATUM 50XD3 SPGT 140512	●	50	40	54	402	150	182	70			

Takım Kodu Ordering Code	Stok Stock	Takım Ölçüleri (mm) Dimension (mm)							Kesici Uç Insert	Yedek Parçaları Spare Parts	
		d	d1	d2	l	l1	l2	l3		Sıkma Vidası Screw	Tork Anahtar Torx Key
ATUM 13XD4 SPGT 050204	●	13	20	25	176	52	74	50		3006-M2x4	
ATUM 14XD4 SPGT 050204	●	14	20	25	184	56	78	50			
ATUM 15XD4 SPGT 050204	●	15	20	25	192	60	82	50			
ATUM 16XD4 SPGT 060204	●	16	25	34	206	64	86	56			
ATUM 17.5XD4 SPGT 060204	●	17.5	25	34	214	68	90	56			
ATUM 18XD4 SPGT 060204	●	18	25	34	222	72	94	56		3007-M2.2x5	
ATUM 19XD4 SPGT 060204	●	19	25	34	230	76	98	56			
ATUM 19.5XD4 SPGT 060204	●	19.5	25	34	230	76	98	56			
ATUM 20XD4 SPGT 060204	●	20	25	34	238	80	102	56			
ATUM 21XD4 SPGT 060204	●	21	25	34	246	84	106	56			
ATUM 22XD4 SPGT 07T308	●	22	25	34	254	88	110	56		3008-M2.5x6	
ATUM 23XD4 SPGT 07T308	●	23	25	34	262	92	114	56			
ATUM 23.5XD4 SPGT 07T308	●	23.5	25	34	262	92	114	56			
ATUM 24XD4 SPGT 07T308	●	24	25	34	270	96	118	56			
ATUM 25XD4 SPGT 07T308	●	25	25	34	278	100	122	56			
ATUM 26XD4 SPGT 07T308	●	26	25	34	286	104	126	56		4015-M3.5x9	
ATUM 27.5XD4 SPGT 07T308	●	27.5	25	34	294	108	130	56			
ATUM 28XD4 SPGT 090408	●	28	25	34	302	112	134	56			
ATUM 29XD4 SPGT 090408	●	29	25	34	310	116	138	56			
ATUM 30XD4 SPGT 090408	●	30	32	44	327	120	147	60			
ATUM 33.5XD4 SPGT 090408	●	33.5	32	44	351	132	159	60		1515-M4x11	
ATUM 38XD4 SPGT 110408	●	38	32	44	391	152	179	60			

R: Sağ/Right L: Sol/Left ● Stokta/In Stock ○ Stokta Yok/Non Stock Item
ZCC Ucuna Uygundur. / Compatible with ZCC Insert.

Sipariş Örneği/Ordering Example : 1 ad./pcs. ATUM 34XD3 SPGT 110408
Takma Uçlu Matkap Kullanım Kılavuzu : S 228 / User's Guide For U-Drills : P 228



Delme Derinliği = 3xÇap
Drilling Depth = 3xDiameter

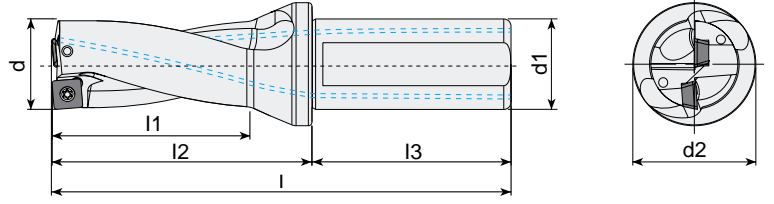

Takım Kodu Ordering Code	Stok Stock	Takım Ölçüleri (mm) Dimension (mm)							Kesici Uç Insert	Yedek Parçaları Spare Parts	
		d	d1	d2	l	l1	l2	l3		Sıkma Vidası Screw	Tork Anahtar Torx Key
ATUM 14XD3 SO.. 050204	●	14	20	25	156	42	64	50	SO.. 050204	3006-M2x4	80-T06
ATUM 15XD3 SO.. 050204	●	15	20	25	162	45	67	50			
ATUM 16XD3 SO.. 050204	●	16	25	34	174	48	70	56			
ATUM 16.5XD3 SO.. 050204	●	16.5	25	34	174	48	70	56			
ATUM 17XD3 SO.. 050204	●	17	25	34	180	51	73	56	SO.. 060304	3007-M2.2x5	80-T07
ATUM 17.5XD3 SO.. 050204	●	17.5	25	34	180	51	73	56			
ATUM 18XD3 SO.. 060304	●	18	25	34	186	54	76	56	SO.. 070305	3008-M2.5x6	80-T08
ATUM 20XD3 SO.. 060304	●	20	25	34	198	60	82	56			
ATUM 22XD3 SO.. 070305	●	22	25	34	210	66	88	56			
ATUM 22.5XD3 SO.. 070305	●	22.5	25	34	210	66	88	56	SO.. 09T306	4010-M3x8	80-T10
ATUM 23XD3 SO.. 070305	●	23	25	34	216	69	91	56			
ATUM 24XD3 SO.. 070305	●	24	25	34	222	72	94	56	SO.. 09T306	4010-M3x8	80-T10
ATUM 25XD3 SO.. 09T306	●	25	25	34	228	75	97	56			
ATUM 26XD3 SO.. 09T306	●	26	25	34	234	78	100	56			
ATUM 30XD3 SO.. 09T306	●	30	32	44	267	90	117	60			



Delme Derinliği = 4xÇap
Drilling Depth = 4xDiameter

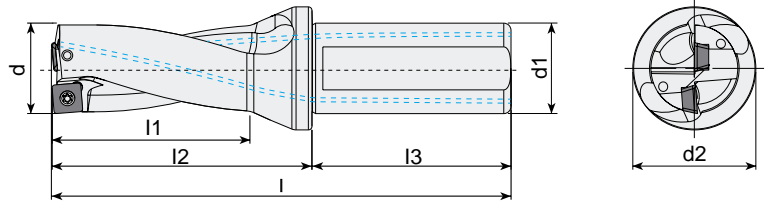

Takım Kodu Ordering Code	Stok Stock	Takım Ölçüleri (mm) Dimension (mm)							Kesici Uç Insert	Yedek Parçaları Spare Parts	
		d	d1	d2	l	l1	l2	l3		Sıkma Vidası Screw	Tork Anahtar Torx Key
ATUM 14XD4 SO.. 050204	●	14	20	25	184	56	78	50	SO.. 050204	3006-M2x4	80-T06
ATUM 14.5XD4 SO.. 050204	●	14.5	20	25	184	56	78	50			
ATUM 15.5XD4 SO.. 050204	●	15.5	20	25	192	60	82	50			
ATUM 17XD4 SO.. 050204	●	17	25	34	214	68	90	56			
ATUM 19XD4 SO.. 060304	●	19	25	34	230	76	98	56	SO.. 060304	3007-M2.2x5	80-T07
ATUM 19.5XD4 SO.. 060304	●	19.5	25	34	230	76	98	56			
ATUM 20XD4 SO.. 060304	●	20	25	34	238	80	102	56	SO.. 070305	3008-M2.5x6	80-T08
ATUM 22XD4 SO.. 070305	●	22	25	34	254	88	110	56			
ATUM 22.5XD4 SO.. 070305	●	22.5	25	34	254	88	110	56			

R: Sağ/Right L: Sol/Left ● Stokta/In Stock ○ Stokta Yok/Non Stock Item
ISCR Ucuna Uygundur. / Compatible with ISCR Insert.

Sipariş Örneği/Ordering Example : 1 ad./pcs. ATUM 14XD3 SO.. 050204
Takma Uçlu Matkap Kullanım Kılavuzu : S 228 / User's Guide For U-Drills : P 228

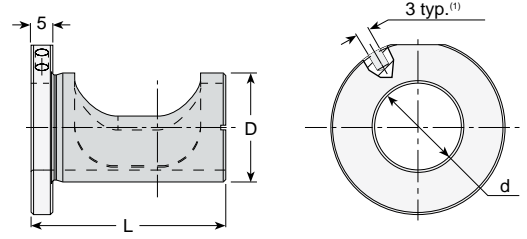

Takım Kodu Ordering Code	Stok Stock	Takım Ölçüleri (mm) Dimension (mm)		
		d	D	L
AET-2025	●	20	25	44
AET-2532	●	25	32	46
AET-3240	●	32	40	55

■⁽¹⁾ Delik ince bir metal yardımıyla adaptörün radyal olarak ayarlanmasını kolaylaştırmak için kullanılır. / Holes for inserting a pin, used to facilitate radial adjustment of the sleeve (pin not supplied).

Frezeleme tezgahında takma uçlu matkabın nominal çapı, matkabın ekseninin, spindle eksenine göre ötelenmesiyle değiştirilebilir.

On a milling machine the drill's nominal diameter can be changed by shifting the drill's axis out of the tool spindle.

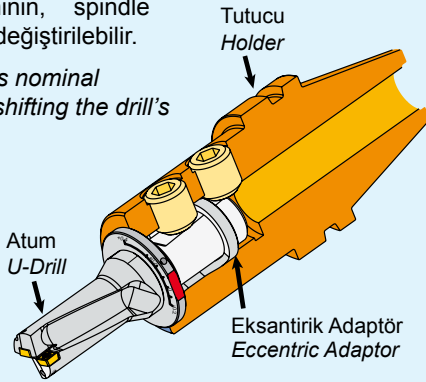
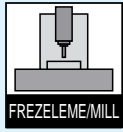

Radyal ayarlama pimi.
(Verilmeyecektir.)

Radial adjustment
pin. (not supplied)

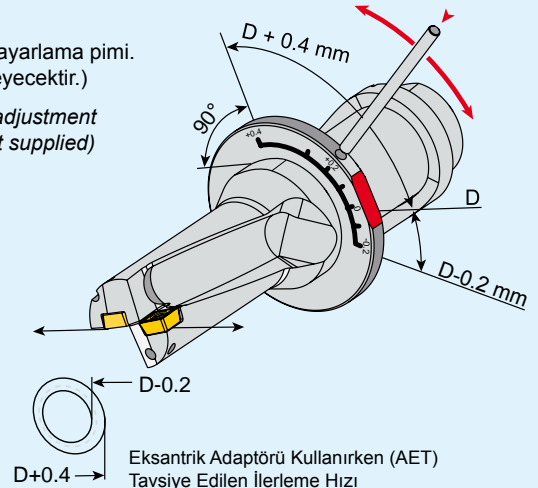

Eksantrik Adaptörü Kullanırken (AET)
Tavsiye Edilen İlerleme Hızı
Recommended Feed When Using Eccentric Adaptor

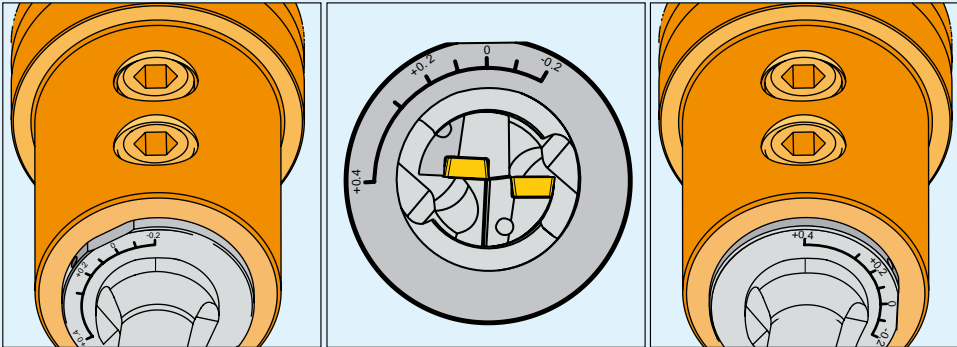
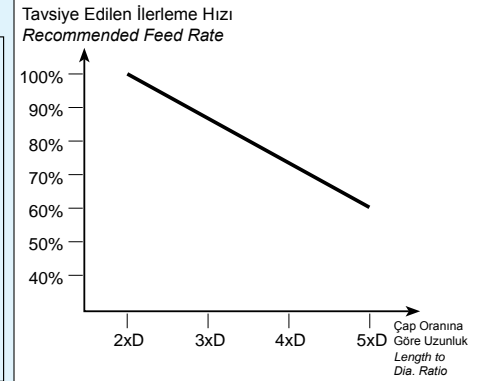

Delik Çapı
24.8 mm
Hole Diameter

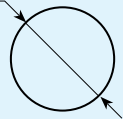

U-Drill Çapı = 25 mm
Drill Diameter = 25 mm

Delik Çapı
25 mm
Hole Diameter

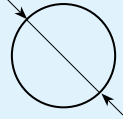

U-Drill Çapı = 25 mm
Drill Diameter = 25 mm

Delik Çapı
25.4 mm
Hole Diameter

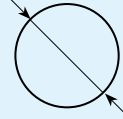

U-Drill Çapı = 25 mm
Drill Diameter = 25 mm

ATUM'un üzerindeki düz çizgi adaptörün sıfır rakamının üzerine konulmalıdır. AET'nin (eksantrik adaptörün) çevrilmesini kolaylaştırmak için AET'nin üzerindeki deliğe, metal bir çubuk ya da vida anahtarı yerleştirilebilir. AET'yi ayarlamadan önce tutucunun vidasını hafifçe çözün.

The adjustment markings should be located perpendicular to the flat on the circumference of the U-DRILL flange.

To facilitate the rotation of the adaptor, a metal rod or a screw key may be inserted into a hole on the eccentric adaptor flange. Unlock adapter screw before adjusting adaptor.



*konusulan
the spoken kalite...
quality...*

EKONOMİK KESİCİLER

EKONOMİK KESİCİLER
ECONOMIC CUTTING TOOLS





AKKO **A** **EK** **R** - **D2.25** x **20**

X **C** . **10** **T3** **04**

2 Kesiş Stili / Cutter Style

EK : Ekonomik Kesici / Economic Cutting

3 Kesme Yönü / Cutting Direction

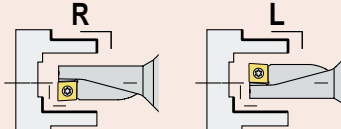

11 Kalınlık / Thickness

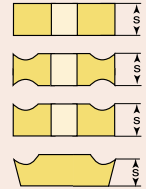

01	s = 1.59
T1	s = 1.98
02	s = 2.38
T2	s = 2.78
03	s = 3.18
T3	s = 3.97
04	s = 4.76
05	s = 5.56
06	s = 6.35
07	s = 7.94
09	s = 9.52

4 Delme Derinliği / Drilling Depth

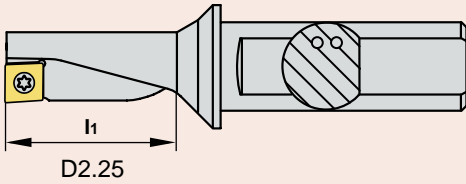

5 Takım Çapı / Tool Diameter

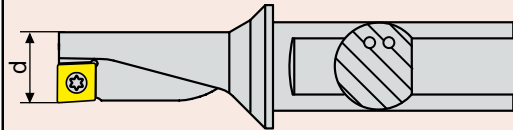

6 Uç Şekli / Insert Form



X



Q

7 Serbest Uç Açısı / Clearance Angle of Insert

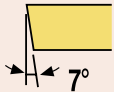

C

8 Toleranslar / Tolerance Classes

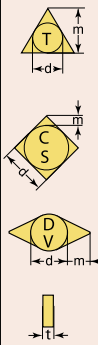

	d	m	t
A	± 0.025	± 0.005	± 0.025
C	± 0.025	± 0.013	± 0.025
E	± 0.025	± 0.025	± 0.025
F	± 0.013	± 0.005	± 0.025
G	± 0.025	± 0.025	± 0.130
H	± 0.013	± 0.013	± 0.025
J	± 0.05-0.15	± 0.005	± 0.025
K	± 0.05-0.15	± 0.013	± 0.025
L	± 0.05-0.15	± 0.025	± 0.025
M	± 0.05-0.15	± 0.08-0.20	± 0.130
N	± 0.05-0.15	± 0.08-0.20	± 0.025
U	± 0.08-0.25	± 0.13-0.38	± 0.130

d : Daire Ölçüsü / Inscribed Circle
m : Şekle Göre / Refer to Figure
t : Kalınlık / Thickness

9 Uç Tipi / Type of Insert

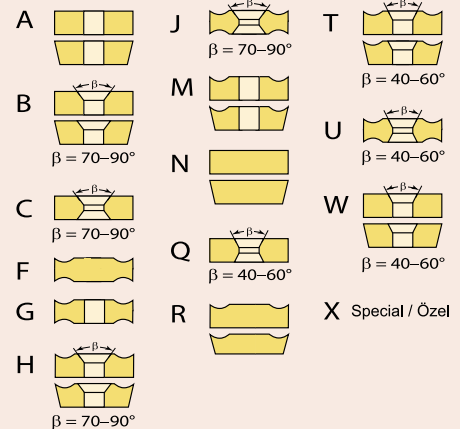

10 Kesme Kenar Uzunluğu / Cutting Edge Length

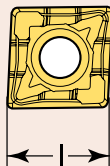

12 Köşe Konfigürasyonu / Corner Radius

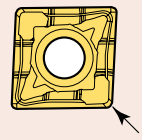

01	r = 0.1	12	r = 1.2
02	r = 0.2	16	r = 1.6
04	r = 0.4	24	r = 2.4
08	r = 0.8		

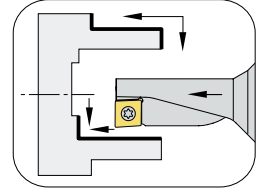
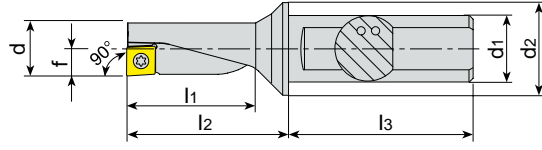

Takım Kodu Ordering Code	Stok Stock		Takım Ölçüleri (mm) Dimension (mm)							Kesici Uç Insert	Yedek Parçaları Spare Parts	
	R	L	d	d ₁	d ₂	l ₁	l ₂	l ₃	f	Sıkma Vidası Screw	Tork Anahtar Torx Key	
AEKL/R-D2.25X8 XC.. 040104	●	●	8	10	12	18	22	38	4		3006-M1.8x4	80-T06
AEKL/R-D2.25X10 XC.. 050204	●	●	10	12	16	22.5	27.5	42	5		3006-M2x4	
AEKL/R-D2.25X12 XC.. 060204	●	●	12	16	20	27	33	45	6		3007-M2.2x5	80-T07
AEKL/R-D2.25X14 XC.. 070304	●	●	14	16	20	31.5	38	45	7		3008-M2.5x6	80-T08
AEKL/R-D2.25X16 XC.. 080304	●	●	16	20	25	36	44	50	8		1008-M3x6	
AEKL/R-D2.25X18 XC.. 09T304	●	●	18	25	32	40.5	50	56	9		4015-M3.5x9	80-T15
AEKL/R-D2.25X20 XC.. 10T304	●	●	20	25	32	45	55	56	10		4020-M4.5x10	80-T20
AEKL/R-D2.25X25 XC.. 130404	●	●	25	32	40	56.5	69	60	12.5		4020-M4.5x12	
AEKL/R-D2.25X32 XC.. 170504	●	●	32	40	50	72	88	70	16		4020-M4.5x12	

R: Sağ/Right L: Sol/Left ● Stokta/In Stock ○ Stokta Yok/Non Stock Item
CRTZT-ISCR-TGTC-KRLY Ucuna Uygundur. / Compatible with CRTZT-ISCR-TGTC-KRLY Insert.

Sipariş Örneği/Ordering Example : 1 ad./pcs. AEKL-D2.25X8 XC.. 040104

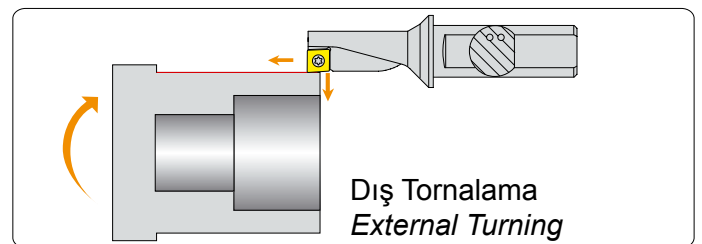
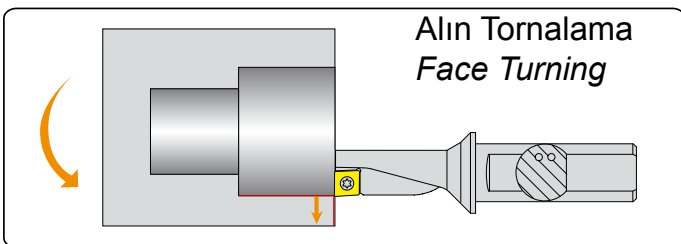
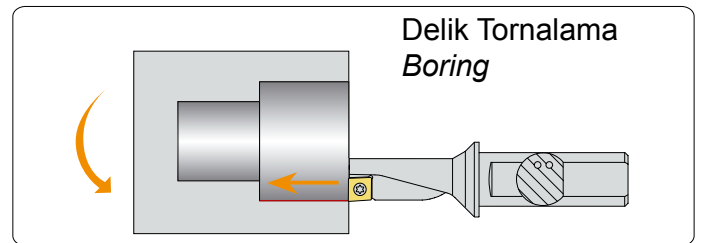
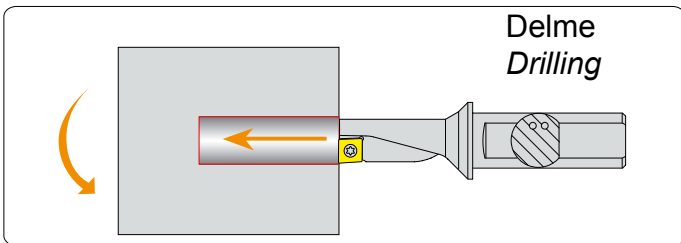
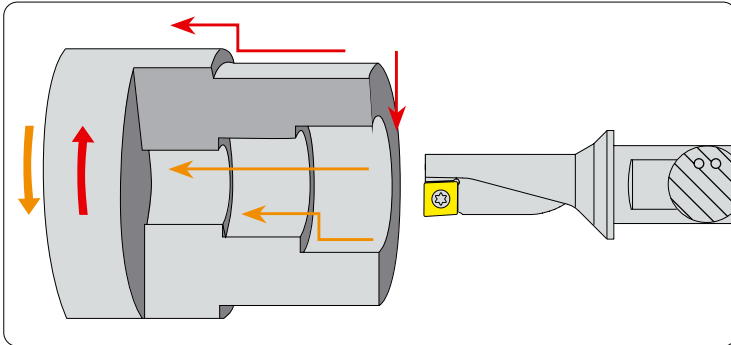

BARALAR

AYARLI DELİK İŞLEME BARALARI
ADJUSTABLE BORING HEADS

*konuşulan
the spoken kalite...
quality...*



AKKO **A** **BH** **R** - **D16x42**

W16 - **L90**

2 Kesiş Stili / Cutter Style

BH : Delik İşleme / Boring Head

3 İşlem Tipi / Cutter Type

R : Kaba Baralama / Rough Boring
F : Hassas Baralama / Fine Boring

5 Montaj Formu / Assembly Form

W : Weldon

4 Takım Çapı / Tool Diameter

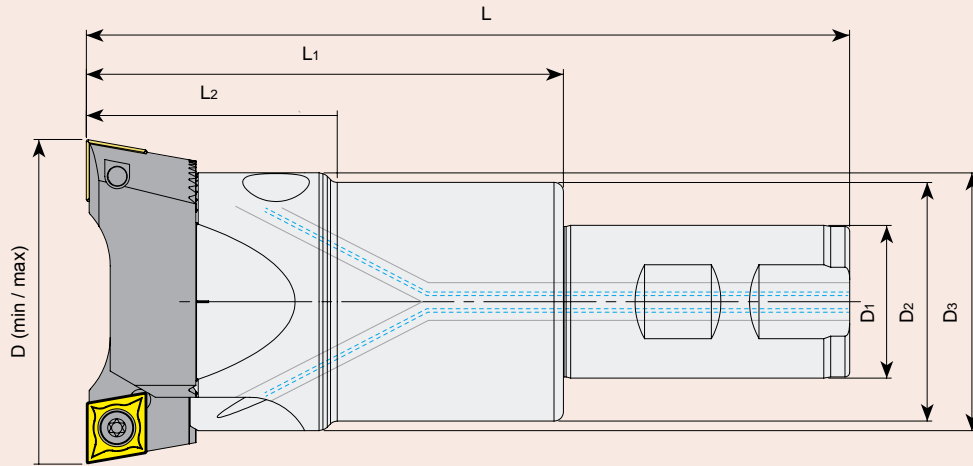

6 Takım Boyu / Tool Length

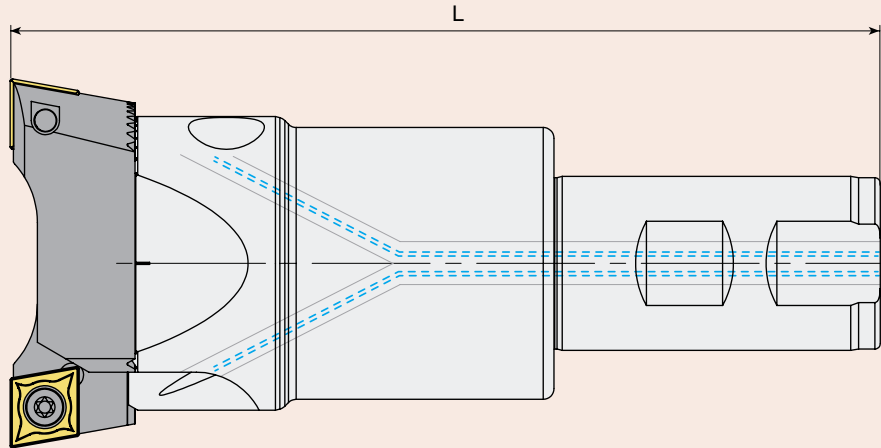

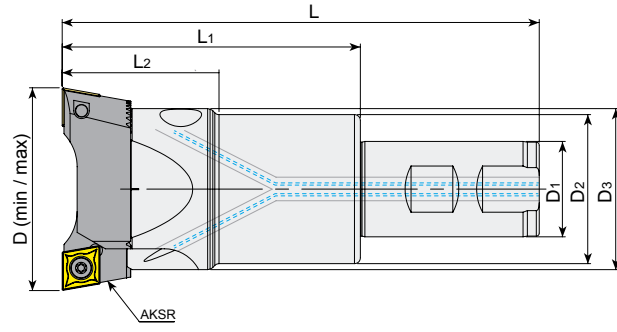

DIN 1835

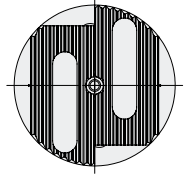

Takım Kodu Ordering Code	Stok Stock	Ölçü Aralığı Boring Range D (min/max)	Takım Ölçüleri (mm) Dimension (mm)					Kartuş Cartridge	Yedek Parçaları Spare Parts			
			D1	D2	D3	L	L1		L2	Pabuç Clamp	Kartuş Vidası Cartridge Screw	Ayar Vidası Adjusting Screw
ABHR-D18x22-W16-L90-CC06	●	18-22	16	-	-	90	42	-	AK.. 18-22	ABKS-D16	2525-M3X14	2715-M3X4
ABHR-D22x28-W20-L100-CC06	●	22-28	20	-	-	100	50	-	AK.. 22-28	ABKS-D20	2503-M4X15	2715-M3X5
ABHR-D28x38-W20-L110-CC06	●	28-38	20	25	-	110	60	-	AK.. 28-38	ABKS-D25	2503-M4X20	2715-M3X8
ABHR-D36x50-W25-L120-CC06	●	36-50	25	32	-	120	64	-	AK.. 36-50	ABKS-D32	2504-M5X25	2702-M4X12
ABHR-D36x50-W25-L120-CC09	●	36-50	25	32	-	120	64	-	AK.. 36-50-09	ABKS-D32	2504-M5X25	2702-M4X12
ABHR-D50x68-W32-L140-CC09	●	50-68	32	40	-	140	80	-	AK.. 50-68	ABKS-D40	2505-M6X30	2725-M5X14
ABHR-D50x68-W32-L140-CC12	●	50-68	32	40	-	140	80	-	AK.. 50-68-12	ABKS-D40	2505-M6X30	2725-M5X14
ABHR-D68x90-W32-L160-CC12	●	68-90	32	50	54	160	100	50	AK.. 68-90	ABKS-D50	2506-M8X35	2725-M5X12
ABHR-D90x120-W32-L140-CC12	●	90-120	32	63	72	140	80	63	AK.. 90-120	ABKS-D63	2508-M10X40	2703-M6X16
ABHR-D90x120-W40-L200-CC12	●	90-120	40	63	72	200	130	63	AK.. 90-120	ABKS-D63	2508-M10X40	2703-M6X16
ABHR-D120x160-W40-L210-CC12	●	120-160	40	80	95	210	140	75	AK.. 120-160	ABKS-D80	2510-M12X40	2704-M8X25
ABHR-D160x200-W40-L210-B-CC12	●	160-200	40	80	95	210	140	75	AK.. 160-800	ABKS-D80	2510-M12X40	2704-M8X25



R: Sağ/Right L: Sol/Left ● Stokta/In Stock ○ Stokta Yok/Non Stock Item

Siparişte, gövde ve kartuş set olarak verilecektir. / When ordered, body and cartridge will be sent as set.

Sipariş Örneği/Ordering Example : 1 ad./pcs. ABHR-D18x22-W16-L90-CC06

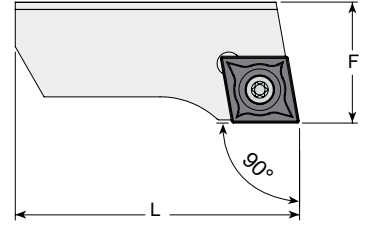



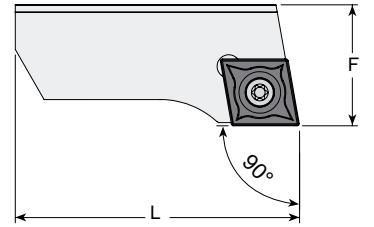

Takım Kodu Ordering Code	Stok Stock	Takım Ölçüleri (mm) Dimension (mm)			Yedek Parçaları Spare Parts		
		Ölçü Aralığı Boring Range	F	L	Kesici Uç Insert	Sıkma Vidası Screw	Tork Anahtar Torx Key
							
AKSR 18-22	●	18-22	9	15	CC.. 0602..	4008-M2.5x6	80-T08
AKSR 22-28	●	22-28	10	19			
AKSR 28-38	●	28-38	13	23			
AKSR 36-50	●	36-50	16	32	CC.. 09T3..	4015-M3.5x8	80-T15
AKSR 36-50-09	●	36-50	16	32			
AKSR 50-68	●	50-68	20	40			
AKSR 50-68-12	●	50-68	20	40	CC.. 1204..	1020-M5x11	80-T20
AKSR 68-90	●	68-90	23	54			
AKSR 90-120	●	90-120	28	70			
AKSR 120-160	●	120-160	32	95			
AKSR 160-800	●	160-800	32	120			

ISO Ucuna Uygunudur. / Compatible with ISO Insert.

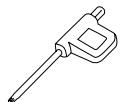

Takım Kodu Ordering Code	Stok Stock	Takım Ölçüleri (mm) Dimension (mm)			Yedek Parçaları Spare Parts		
		Ölçü Aralığı Boring Range	F	L	Kesici Uç Insert	Sıkma Vidası Screw	Tork Anahtar Torx Key
							
AKCR 28-38	●	28-38	12.8	23	CC.. 0602..	4008-M2.5x6	80-T08
AKCR 36-50	●	36-50	15.8	32			
AKCR 36-50-09	●	36-50	15.8	32			
AKCR 50-68	●	50-68	19.7	40	CC.. 09T3..	4015-M3.5x8	80-T15
AKCR 50-68-12	●	50-68	19.7	40			
AKCR 68-90	●	68-90	22.7	54			
AKCR 90-120	●	90-120	27.7	70	CC.. 1204..	1020-M5x11	80-T20
AKCR 120-160	●	120-160	31.7	95			
AKCR 160-800	●	160-800	31.7	120			

R: Sağ/Right L: Sol/Left ● Stokta/In Stock ○ Stokta Yok/Non Stock Item
ISO Ucuna Uygunudur. / Compatible with ISO Insert.

Sipariş Örneği/Ordering Example : 1 ad./pcs. AKSR 18-22

*konusulan
the spoken kalite...
quality...*

FREZELEME TAKIMLARI
MILLING TOOLS



AKKO
A

1

EM

2

90

3

A

4

P

5

10

6

D12

7

W16

8

L100

9

Z01

10

H

11

2 Kesiş Stili / Cutter Style

FM: Yüze Frezeleme Takımları - Face Milling Tools
EM: Alın ve Yüze Parmak Frezeleri - End Face Milling Tools
CM: Pah Kırma Parmak Frezeleri - Chamfering End Milling Tools
HM: Helis Parmak Frezeleri - Helix End Milling Tools
TSM: T Kanal Frezeleri - T Slot Milling Tools
HFM: Yüksek İlerleme Frezeleme Takımları - High Feed Milling Tools
PMR: Küresel Uçlu Parmak Frezeleri - Ball Nose End Milling Tools
SDM: Disk Frezeler / Slot Disc Milling
CBM: Silindirik Alyan Başlı Vida Havşalarını Açma Frezeleri
Countersink Milling Tool for Cylindrical Allen Head Screws

3 Freze Yanaşma Açısı / Lead Angle

90° - 75° - 60° - 45°
20° - 15° - 11° - 5° - 0°

6 Kesme Kenar Uzunluğu / Cutting Edge Length

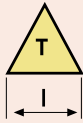
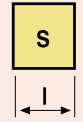
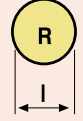
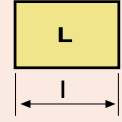
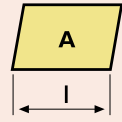

4 Uç Tipi / Insert Shape

C	D	E	K
L	R	S	T
V	W	A	B
H	M	O	P

5 Serbest Uç Açısı / Clearance angle of Insert

A	B	C
D	E	F
G	N	P

7 Takım Çapı / Tool Diameter

8 Montaj Formu ve Çapı / Assembly Form and Diameter

A, B, C, D,: ISO'ya göre montaj formu / Assembly form according to ISO
C: Silindirik Şaft / Cylindrical Shank
W: Weldon

9 Takım Boyu / Tool Length

10 Etkili Diş Adedi / Number of Effective Tooth

11 İçten Soğutmalı / With Coolant Hole

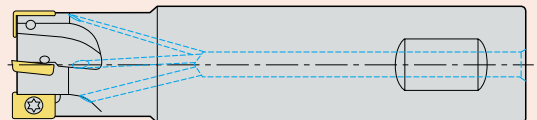

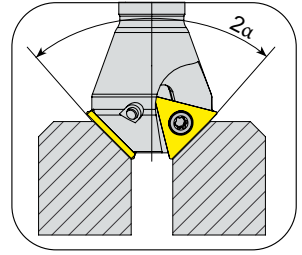
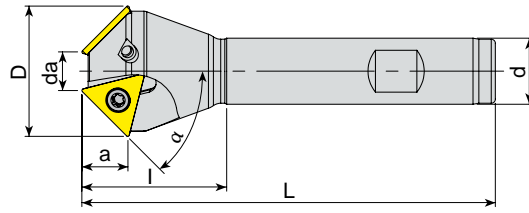

Takım Kodu Ordering Code	Stok Stock	Takım Ölçüleri (mm) Dimension (mm)							Kesici Uç Insert	Yedek Parçaları Spare Parts		
		α	da	D	d	L	l	Z		a	Sıkma Vidası Screw	Tork Anahtar Torx Key
ACM10-TC16-D17X20-W16-L90-Z01	●	10°	17	20	16	90	30	1	15.2			
ACM15-TC16-D17X22-W16-L90-Z01	●	15°	17	22	16	90	30	1	14.9			
ACM17.5-TC16-D17X24-W16-L90-Z01	●	17.5°	17	24	16	90	30	1	14.7			
ACM18.5-TC16-D21.3X30-W20-L100-Z02	●	18.5°	21.3	30	20	100	30	2	13.5			
ACM20-TC16-D12X20-W16-L100-Z01	●	20°	12	20	16	100	30	1	14.4			
ACM20-TC16-D17X26-W16-L100-Z01	●	20°	17	26	16	100	30	1	14.4			
ACM22.5-TC16-D17X28-W16-L100-Z01	●	22.5°	17	28	16	100	30	1	14.2			
ACM25-TC16-D17X30-W16-L100-Z01	●	25°	17	30	16	100	30	1	13.9			
ACM30-TC16-D6X20-W16-L100-Z01	●	30°	6	20	16	100	30	1	13.3			
ACM30-TC16-D20X35-W16-L100-Z02	●	30°	20	35	16	100	35	2	13.3			
ACM30-TC16-D30X45-W20-L100-Z02	●	30°	30	45	20	100	40	2	13.3			
ACM45-TC09-D7X19-W16-L100-Z02	●	45°	7	19	16	100	25	2	5.9	TC.T 090204	3007-M2.2x5	80-T07
ACM45-TC11-D11X24-W16-L100-Z02	●	45°	11	24	16	100	25	2	6.9	TC.T 110204	3008-M2.5x6	80-T08
ACM45-TC16-D5X23-W16-L100-Z01	●	45°	5	23	16	100	30	1	10.8	TC.T 16T304	4015-M3.5x9	80-T15
ACM45-TC16-D10X30-W16-L100-Z02	●	45°	10	30	16	100	35	2	10.8			
ACM45-TC16-D10X30-W20-L100-Z02	●	45°	10	30	20	100	35	2	10.8			
ACM45-TC16-D18X37-W20-L100-Z02	●	45°	18	37	20	100	40	2	10.8			
ACM45-TC16-D20X40-W20-L100-Z02	●	45°	20	40	20	100	40	2	10.8			
ACM45-TC16-D30X50-W20-L100-Z02	●	45°	30	50	20	100	40	2	10.8			
ACM55-TC16-D16X40-W20-L100-Z03	●	55°	16	40	20	100	40	3	8.7			
ACM62-TC16-D14X40-W20-L100-Z03	●	62°	14	40	20	100	40	3	7.1			

R: Sağ/Right L: Sol/Left ● Stokta/In Stock ○ Stokta Yok/Non Stock Item
ISO Ucuna Uygunudur. / Compatible with ISO Insert.

Sipariş Örneği/Ordering Example : 1 ad./pcs. ACM10-TC16-D17X20-W16-L90-Z01
Kesme Hesabı : S 229 / Cutting Calculation : P 229



> S-SİSTEM PAH FREZELER
S-SYSTEM CHAMFERING END MILLS

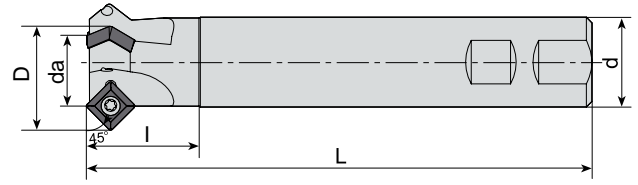

Takım Kodu Ordering Code	Stok Stock	Takım Ölçüleri (mm) Dimension (mm)								Kesici Uç Insert	Yedek Parçaları Spare Parts	
		α	da	D	d	L	l	Z	a		Sıkma Vidası Screw	Tork Anahtar Torx Key
ACM45-SP1104-D12x26-W20-L150-Z01	●	45°	12	26	20	150	30	1	-	SPGT 110408	1515-M4x11	80-T15
ACM45-SP1104-D25x39-W25-L150-Z02	●	45°	25	39	25	150	35	2	-			
ACM45-SP1104-D32x46-W32-L150-Z03	●	45°	32	46	32	150	40	3	-			

ZCC Ucuna Uygundur. / Compatible with ZCC Insert.

> SİLİNDİRİK ALYAN BAŞLI VİDA (DIN 974-1) HAVŞALARINI AÇMA FREZELERİ
COUNTERSINK MILLING TOOL FOR CYLINDRICAL ALLEN HEAD SCREWS (DIN 974-1)

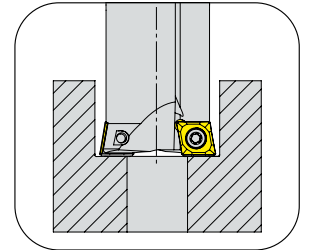
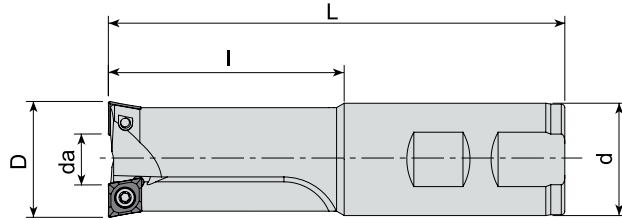

Takım Kodu Ordering Code	Stok Stock	Takım Ölçüleri (mm) Dimension (mm)							Kesici Uç Insert	Yedek Parçaları Spare Parts	
		da	D	d	l	L	Kullanılan Vidalar For Screws	Sıkma Vidası Screw		Tork Anahtar Torx Key	
ACBM-CC06-D17X6-W16-L150-Z02	●	6	17	16	30	150	-	CC.. 0602..	3008-M2.5x6	80-T08	
ACBM-CC06-D18X7-W16-L100-Z02-H	●	7	18	16	32	100	M10				
ACBM-CC06-D18X7-W16-L160-Z02-H	●	7	18	16	32	160	M10				
ACBM-CC06-D20X9-W20-L100-Z02-H	●	9	20	20	40	100	M12	CC.. 09T3..	4015-M3.5x9	80-T15	
ACBM-CC06-D20X9-W20-L160-Z02-H	●	9	20	20	38	160	M12				
ACBM-CC09-D26X8.5-W25-L130-Z02-H	●	8.5	26	25	50	130	M16				
ACBM-CC09-D26X8.5-W25-L200-Z02	●	8.5	26	25	50	200	M16	SP.. 060204	3007-M2.2x5	80-T07	
ACBM-CC09-D33X15.5-W32-L130-Z02-H	●	15.5	33	32	65	130	M20				
ACBM-CC09-D33X15.5-W32-L200-Z2	●	15.5	33	32	65	200	M20				
ACBM-SP06-D15X4-W16-L160-Z02-H	●	4	15	16	80	160	M8				

R: Sağ/Right L: Sol/Left ● Stokta/In Stock ○ Stokta Yok/Non Stock Item
ISO Ucuna Uygundur. / Compatible with ISO Insert.

Sipariş Örneği/Ordering Example : 1 ad./pcs. ACM45-SP1104-D12x26-W20-L150-Z01
Kesme Hesabı : S 229 / Cutting Calculation : P 229

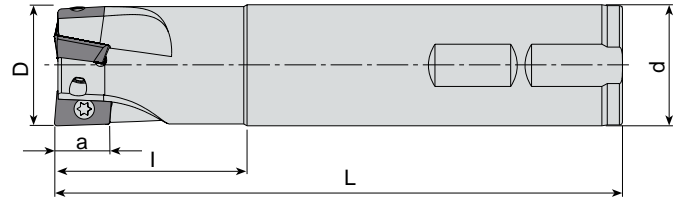

Takım Kodu Ordering Code	Stok Stock	Takım Ölçüleri (mm) Dimension (mm)						Kesici Uç Insert	Yedek Parçaları Spare Parts				
		D	Z	d	L	l	a		Sıkma Vidası Screw	Tork Anahtar Torx Key			
AEM90-AD1505-D25-W25-L150-Z02	●	25	2	25	150	50	15						
AEM90-AD1505-D30-W25-L150-Z03	●	30	3	25	150	40	15				AD.. 1505..	1515-M4x9	80-T15
AEM90-AD1505-D32-W32-L150-Z03	●	32	3	32	150	50	15						

ISCR Ucuna Uygunudur. / Compatiple with ISCR Insert.

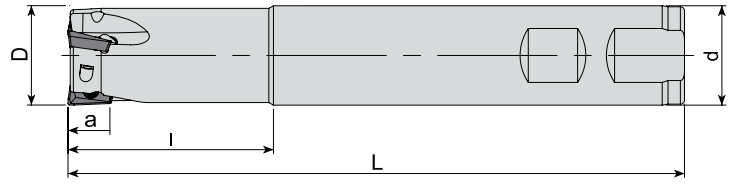

Takım Kodu Ordering Code	Stok Stock	Takım Ölçüleri (mm) Dimension (mm)						Kesici Uç Insert	Yedek Parçaları Spare Parts	
		D	Z	d	L	l	a		Sıkma Vidası Screw	Tork Anahtar Torx Key
AEM90-AD10T3-D16-W16-L100-Z02-H	●	16	2	16	100	30	10			
AEM90-AD10T3-D16-W16-L150-Z02	●	16	2	16	150	40	10			
AEM90-AD10T3-D20-W20-L70-Z03	●	20	3	20	100	30	10			
AEM90-AD10T3-D20-W20-L100-Z03-H	●	20	3	20	100	30	10			
AEM90-AD10T3-D20-W20-L150-Z03	●	20	3	20	150	40	10			
AEM90-AD10T3-D20-C20-L150-Z03	●	20	3	20	150	40	10			
AEM90-AD10T3-D25-W25-L100-Z03-H	●	25	3	25	100	30	10			
AEM90-AD10T3-D25-W25-L150-Z03	●	25	3	25	150	50	10	ADMT 10T3..	3008-M2.5x6	80-T15
AEM90-AD1204-D20-W20-L150-Z02	●	20	2	20	150	50	12			
AEM90-AD1204-D25-W25-L150-Z03	●	25	3	25	150	50	12			
AEM90-AD1204-D32-W32-L150-Z04	●	32	4	32	150	50	12	ADMT 1606..	1515-M4x9	80-T15
AEM90-AD1606-D25-W25-L150-Z02	●	25	2	25	150	50	15			
AEM90-AD1606-D32-W32-L150-Z03	●	32	3	32	150	50	15			

R: Sağ/Right L: Sol/Left ● Stokta/In Stock ○ Stokta Yok/Non Stock Item
WLTR Ucuna Uygunudur. / Compatiple with WLTR Insert.

Sipariş Örneği/Ordering Example : 1 ad./pcs. AEM90-AD1505-D25-W25-L150-Z02
Kesme Hesabı : S 229 / Cutting Calculation : P 229

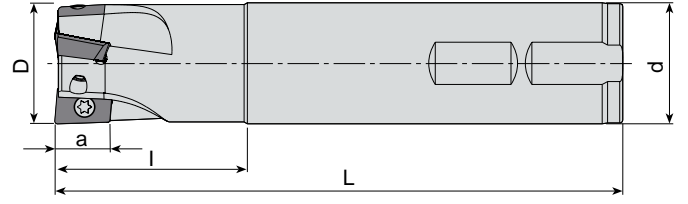

Takım Kodu Ordering Code	Stok Stock	Takım Ölçüleri (mm) Dimension (mm)						Kesici Uç Insert	Yedek Parçaları Spare Parts	
		D	Z	d	L	l	a		Sıkma Vidası Screw	Tork Anahtar Torx Key
AEM90-AD1505D-D25-W25-L150-Z02	●	25	2	25	150	50	14.3	ADKT 150508	1515-M4x9	80-T15
AEM90-AD1505D-D32-W32-L150-Z03	●	32	3	32	150	50	14.3		1515-M4x11	

DJT Ucuna Uygunudur. / Compatiple with DJT Insert.

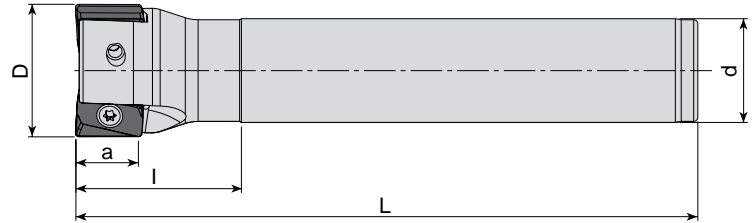

Takım Kodu Ordering Code	Stok Stock	Takım Ölçüleri (mm) Dimension (mm)						Kesici Uç Insert	Yedek Parçaları Spare Parts	
		D	Z	d	L	l	a		Sıkma Vidası Screw	Tork Anahtar Torx Key
AEM90-AN11-D22-W20-L150-Z02	●	22	2	20	150	30	11	ANGX 110508	4010-M3x8	80-T10
AEM90-AN11-D25-W25-L150-Z02	●	25	2	25	150	40	11			
AEM90-AN11-D25-C25-L200-Z02	●	25	2	25	200	40	11			
AEM90-AN11-D26-W25-L150-Z02	●	26	2	25	150	40	11			
AEM90-AN11-D28-W25-L150-Z02	●	28	2	25	150	25	11			
AEM90-AN11-D32-W32-L150-Z03	●	32	3	32	150	50	11			
AEM90-AN11-D32-C32-L200-Z03	●	32	3	32	200	50	11			
AEM90-AN11-D40-W32-L150-Z04	●	40	4	32	150	40	11			

R: Sağ/Right L: Sol/Left ● Stokta/In Stock ○ Stokta Yok/Non Stock Item
ZCC Ucuna Uygunudur. / Compatiple with ZCC Insert.

Sipariş Örneği/Ordering Example : 1 ad./pcs. AEM90-AD1505D-D25-W25-L150-Z02
Kesme Hesabı : S 229 / Cutting Calculation : P 229

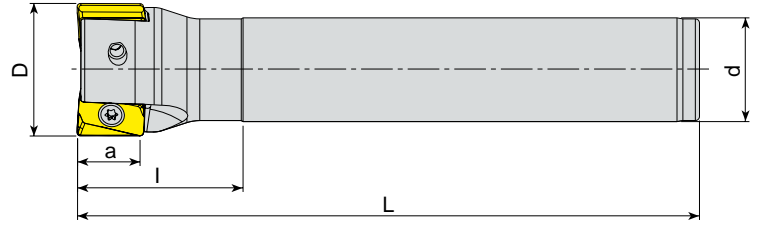

Takım Kodu Ordering Code	Stok Stock	Takım Ölçüleri (mm) Dimension (mm)						Kesici Uç Insert	Yedek Parçaları Spare Parts	
		D	Z	d	L	l	a		Sıkma Vidası Screw	Tork Anahtar Torx Key
AEM90-AN1607-D32-C25-L150-Z02	●	32	2	25	150	50	15	AN.X 1607	1515-M4x11	80-T15
AEM90-AN1607-D40-C32-L150-Z03	●	40	3	32	150	50	15			

TGTC Ucuna Uygundur. / Compatible with TGTC Insert.

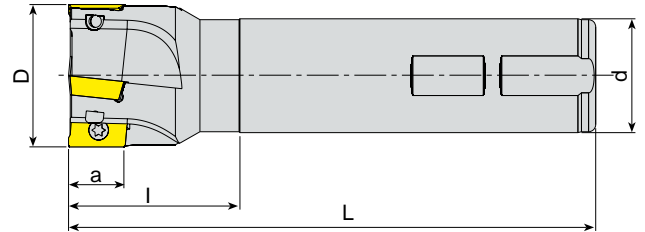



Takım Kodu Ordering Code	Stok Stock	Takım Ölçüleri (mm) Dimension (mm)						Kesici Uç Insert	Yedek Parçaları Spare Parts	
		D	Z	d	L	l	a		Sıkma Vidası Screw	Tork Anahtar Torx Key
AEM90-AP06-D10-C10-L120-Z02	●	10	2	10	120	20	5.6	APMT 0602.. KRLY UCUNA UYGUNDUR. FOR KRLY INSERT.	3006-M1.8x4	80-T06
AEM90-AP06-D12-C12-L120-Z02	●	12	2	12	120	20	5.6			
AEM90-AP0903-D16-C16-L150-Z02	●	16	2	16	150	30	9	APMT 0903.. KRLY UCUNA UYGUNDUR. FOR KRLY INSERT.	3008-M2.5x6	80-T08
AEM90-AP0903-D17-C16-L150-Z02	●	17	2	16	150	30	9			
AEM90-AP0903-D20-C20-L150-Z02	●	20	2	20	150	30	9	APKT 09T3.. TGTC UCUNA UYGUNDUR. FOR TGTC INSERT.	3008-M2.5x5	80-T08
AEM90-AP0903-D21-C20-L150-Z02	●	21	2	20	150	30	9			
AEM90-AP0903-D25-C25-L150-Z03	●	25	3	25	150	30	9	AP.. 1003.. ISO UCUNA UYGUNDUR. FOR ISO INSERT.	3008-M2.5x5	80-T08
AEM90-AP09-D16-C15-L150-Z02	●	16	2	15	150	25	8.8			
AEM90-AP09-D17-C16-L150-Z02	●	17	2	16	150	25	8.8	AP.. 1003.. ISO UCUNA UYGUNDUR. FOR ISO INSERT.	3008-M2.5x5	80-T08
AEM90-AP09-D21-C20-L150-Z03	●	21	3	20	150	25	8.8			
AEM90-AP09-D26-C25-L150-Z04	●	26	4	25	150	30	8.8	AP.. 1003.. ISO UCUNA UYGUNDUR. FOR ISO INSERT.	3008-M2.5x5	80-T08
AEM90-AP10-D12-W16-L100-Z01-H	●	12	1	16	100	30	10			
AEM90-AP10-D12-W16-L150-Z01	●	12	1	16	150	38	10	AP.. 1003.. ISO UCUNA UYGUNDUR. FOR ISO INSERT.	3008-M2.5x5	80-T08
AEM90-AP10-D14-W16-L100-Z01-H	●	14	1	16	100	30	10			
AEM90-AP10-D14-W16-L150-Z01	●	14	1	16	150	38	10	AP.. 1003.. ISO UCUNA UYGUNDUR. FOR ISO INSERT.	3008-M2.5x5	80-T08

R: Sağ/Right L: Sol/Left ● Stokta/In Stock ○ Stokta Yok/Non Stock Item

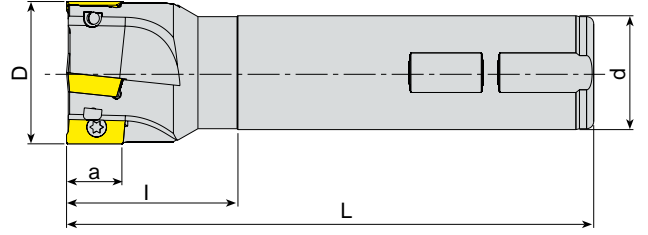
Sipariş Örneği/Ordering Example : 1 ad./pcs. AEM90-AN1607-D32-C25-L150-Z02
Kesme Hesabı : S 229 / Cutting Calculation : P 229





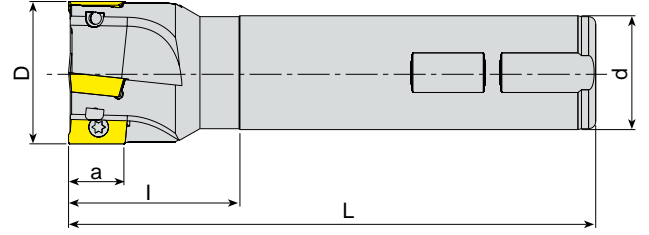

Takım Kodu Ordering Code	Stok Stock	Takım Ölçüleri (mm) Dimension (mm)						Kesici Uç Insert	Yedek Parçaları Spare Parts	
		D	Z	d	L	l	a		Sıkma Vidası Screw	Tork Anahtar Torx Key
AEM90-AP10-D16-C16-L100-Z02-H	●	16	2	16	100	30	10	 AP.. 1003.. ISO UCUNA UYGUNDUR. FOR ISO INSERT.	 3008-M2.5x6	 80-T08
AEM90-AP10-D16-W16-L100-Z02-H	●	16	2	16	100	30	10			
AEM90-AP10-D16-C16-L120-Z02-H	●	16	2	16	120	30	10			
AEM90-AP10-D16-C16-L150-Z02	●	16	2	16	150	50	10			
AEM90-AP10-D16-C16-L150-Z02-H	●	16	2	16	150	50	10			
AEM90-AP10-D16-W16-L150-Z02	●	16	2	16	150	50	10			
AEM90-AP10-D16-C16-L200-Z02	●	16	2	16	200	100	10			
AEM90-AP10-D16-C16-L200-Z02-H	●	16	2	16	200	100	10			
AEM90-AP10-D18-W16-L100-Z02-H	●	18	2	16	100	30	10			
AEM90-AP10-D18-W16-L150-Z02	●	18	2	16	150	30	10			
AEM90-AP10-D20-C20-L100-Z03-H	●	20	3	20	100	30	10			
AEM90-AP10-D20-W20-L100-Z03-H	●	20	3	20	100	30	10			
AEM90-AP10-D20-C20-L120-Z03-H	●	20	3	20	120	30	10			
AEM90-AP10-D20-C20-L150-Z03	●	20	3	20	150	50	10			
AEM90-AP10-D20-C20-L150-Z03-H	●	20	3	20	150	50	10			
AEM90-AP10-D20-W20-L150-Z03	●	20	3	20	150	50	10			
AEM90-AP10-D20-C20-L200-Z02	●	20	2	20	200	100	10			
AEM90-AP10-D20-C20-L200-Z03-H	●	20	3	20	200	100	10			
AEM90-AP10-D20-C20-L250-Z02	●	20	2	20	250	150	10			
AEM90-AP10-D20-C20-L250-Z02-H	●	20	2	20	250	150	10			
AEM90-AP10-D21-W20-L150-Z03	●	21	3	20	150	30	10			
AEM90-AP10-D22-W20-L100-Z03-H	●	22	3	20	100	30	10			
AEM90-AP10-D22-W20-L150-Z03	●	22	3	20	150	30	10			
AEM90-AP10-D23-W20-L150-Z03	●	23	3	20	150	30	10			
AEM90-AP10-D24-W20-L150-Z03	●	24	3	20	150	30	10			
AEM90-AP10-D25-W25-L100-Z04-H	●	25	4	25	100	30	10			
AEM90-AP10-D25-C25-L100-Z03-H	●	25	3	25	100	30	10			
AEM90-AP10-D25-W25-L100-Z03-H	●	25	3	25	100	30	10			
AEM90-AP10-D25-C25-L120-Z03-H	●	25	3	25	120	30	10			
AEM90-AP10-D25-C25-L150-Z03	●	25	3	25	150	50	10			
AEM90-AP10-D25-W25-L150-Z03	●	25	3	25	150	50	10			
AEM90-AP10-D25-C25-L200-Z02	●	25	2	25	200	100	10			
AEM90-AP10-D25-C25-L200-Z03	●	25	3	25	200	100	10			
AEM90-AP10-D25-C25-L250-Z02	●	25	2	25	250	100	10			

R: Sağ/Right L: Sol/Left ● Stokta/In Stock ○ Stokta Yok/Non Stock Item

Sipariş Örneği/Ordering Example : 1 ad./pcs. AEM90-AP10-D16-C16-L100-Z02-H
Kesme Hesabı : S 229 / Cutting Calculation : P 229



Takım Kodu Ordering Code	Stok Stock	Takım Ölçüleri (mm) Dimension (mm)						Kesici Uç Insert	Yedek Parçaları Spare Parts	
		D	Z	d	L	l	a		Sıkma Vidası Screw	Tork Anahtar Torx Key
AEM90-AP10-D30-C25-L100-Z04-H	●	30	4	25	100	30	10	 AP.. 1003.. ISO UCUNA UYGUNDUR. FOR ISO INSERT.		
AEM90-AP10-D30-C25-L120-Z04-H	●	30	4	25	120	30	10			
AEM90-AP10-D30-C25-L150-Z04	●	30	4	25	150	30	10			
AEM90-AP10-D32-C25-L100-Z04-H	●	32	4	25	100	35	10			
AEM90-AP10-D32-C25-L120-Z04-H	●	32	4	25	120	35	10			
AEM90-AP10-D32-C25-L150-Z04	●	32	4	25	150	35	10			
AEM90-AP10-D32-W25-L150-Z04	●	32	4	25	150	35	10			
AEM90-AP10-D32-W32-L150-Z04	●	32	4	32	150	50	10			
AEM90-AP10-D40-W32-L150-Z05	●	40	5	32	150	40	10			
AEM90-AP10D-D16-W16-L150-Z02	●	16	2	16	150	50	10	AP.. 1003.. DJT UCUNA UYGUNDUR. FOR DJT INSERT		
AEM90-AP10D-D20-W20-L150-Z03	●	20	3	20	150	50	10			
AEM90-AP11-D16-C16-L150-Z02	●	16	2	16	150	50	11	AP.. 11T3.. KRLY-ZCC UCUNA UYGUNDUR. FOR KRLY-ZCC INSERT.	3008-M2.5x6	80-T08
AEM90-AP11-D16-C16-L150-Z02-H	●	16	2	16	150	50	11			
AEM90-AP11-D16-W16-L150-Z02	●	16	2	16	150	50	11			
AEM90-AP11-D16-C16-L200-Z02	●	16	2	16	200	100	11			
AEM90-AP11-D17-C16-L150-Z02	●	17	2	16	150	30	11			
AEM90-AP11-D17-C16-L200-Z02	●	17	2	16	200	30	11			
AEM90-AP11-D20-C20-L150-Z03	●	20	3	20	150	50	11			
AEM90-AP11-D20-W20-L150-Z03	●	20	3	20	150	50	11			
AEM90-AP11-D20-W20-L150-Z03-H	●	20	3	20	150	50	11			
AEM90-AP11-D20-C20-L200-Z03	●	20	3	20	200	100	11			
AEM90-AP11-D21-C20-L150-Z03	●	21	3	20	150	30	11			
AEM90-AP11-D21-W20-L150-Z03	●	21	3	20	150	30	11			
AEM90-AP11-D21-W20-L150-Z03-H	●	21	3	20	150	30	11			
AEM90-AP11-D21-C20-L200-Z03	●	21	3	20	200	30	11			
AEM90-AP11-D25-C25-L150-Z03	●	25	3	25	150	50	11			
AEM90-AP11-D25-W25-L150-Z03	●	25	3	25	150	50	11			
AEM90-AP11-D25-W25-L150-Z03-H	●	25	3	25	150	50	11			
AEM90-AP11-D26-C25-L150-Z03	●	26	3	25	150	35	11			
AEM90-AP11-D26-C24-L150-Z03	●	26	3	24	150	47	11			
AEM90-AP11-D32-W25-L150-Z04	●	32	4	25	150	35	11			
AEM90-AP11-D32-W32-L150-Z03-H	●	32	3	32	150	50	11			
AEM90-AP11-D32-W32-L150-Z04	●	32	4	32	150	50	11			

R: Sağ/Right L: Sol/Left ● Stokta/In Stock ○ Stokta Yok/Non Stock Item

Sipariş Örneği/Ordering Example : 1 ad./pcs. AEM90-AP10-D30-C25-L100-Z04-H
Kesme Hesabı : S 229 / Cutting Calculation : P 229

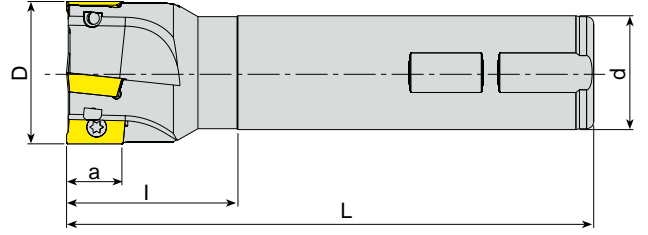

Takım Kodu Ordering Code	Stok Stock	Takım Ölçüleri (mm) Dimension (mm)						Kesici Uç Insert	Yedek Parçaları Spare Parts	
		D	Z	d	L	l	a		Sıkma Vidası Screw	Tork Anahtar Torx Key
AEM90-AP1135-D16-W16-L150-Z02	●	16	2	16	150	50	9.5	AP.. 1135.. GSC UCUNA UYGUNDUR. FOR GSC INSERT	3008-M2.5x6	80-T08
AEM90-AP1135-D20-W20-L150-Z03	●	20	3	20	150	50	9.5			
AEM90-AP1204-D20-C20-L150-Z02	●	20	2	20	150	30	12			
AEM90-AP1204-D21-C20-L150-Z02	●	21	2	20	150	30	12	AP.. 1204.. TGTC UCUNA UYGUNDUR. FOR TGTC INSERT.	1510-M3.5x7	80-T10
AEM90-AP1204-D21-C20-L200-Z02	●	21	2	20	200	30	12			
AEM90-AP1204-D25-C25-L150-Z03	●	25	3	25	150	40	12			
AEM90-AP1204-D26-C25-L250-Z02	●	26	2	25	250	35	12			
AEM90-AP1204-D32-C25-L150-Z03	●	32	3	25	150	35	12			
AEM90-AP16-D25-C20-L100-Z02	●	25	2	20	100	35	16			
AEM90-AP16-D25-W25-L100-Z02-H	●	25	2	25	100	35	16			
AEM90-AP16-D25-W25-L150-Z02	●	25	2	25	150	50	16			
AEM90-AP16-D25-C25-L250-Z02	●	25	2	25	250	100	16			
AEM90-AP16-D28-W25-L100-Z03-H	●	28	3	25	100	40	16			
AEM90-AP16-D28-W25-L150-Z03	●	28	3	25	150	40	16			
AEM90-AP16-D30-W25-L110-Z03-H	●	30	3	25	110	40	16			
AEM90-AP16-D30-W25-L150-Z03	●	30	3	25	150	40	16			
AEM90-AP16-D32-W32-L110-Z03-H	●	32	3	32	110	40	16			
AEM90-AP16-D32-C32-L150-Z03	●	32	3	32	150	50	16			
AEM90-AP16-D32-W25-L150-Z03	●	32	3	25	150	40	16			
AEM90-AP16-D32-W32-L150-Z03	●	32	3	32	150	50	16			
AEM90-AP16-D32-W32-L150-Z03-H	●	32	3	32	150	50	16			
AEM90-AP16-D32-C32-L250-Z02	●	32	2	32	250	100	16			
AEM90-AP16-D32-C32-L250-Z03	●	32	3	32	250	100	16			
AEM90-AP16-D35-W32-L150-Z03	●	35	3	32	150	40	16			
AEM90-AP16-D36-W32-L110-Z03-H	●	36	3	32	110	40	16			
AEM90-AP16-D36-W32-L150-Z03	●	36	3	32	150	40	16			
AEM90-AP16-D40-W32-L110-Z04-H	●	40	4	32	110	40	16			
AEM90-AP16-D40-C32-L150-Z04	●	40	4	32	150	40	16			
AEM90-AP16-D40-W32-L150-Z04	●	40	4	32	150	40	16			
AEM90-AP16-D40-C32-L250-Z02	●	40	2	32	250	40	16			
AEM90-AP16-D40-C32-L250-Z04	●	40	4	32	250	40	16			

R: Sağ/Right L: Sol/Left ● Stokta/In Stock ○ Stokta Yok/Non Stock Item

Sipariş Örneği/Ordering Example : 1 ad./pcs. AEM90-AP1135-D16-W16-L150-Z02

Kesme Hesabı : S 229 / Cutting Calculation : P 229

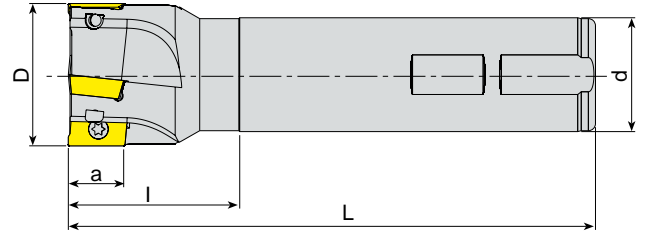

Takım Kodu Ordering Code	Stok Stock	Takım Ölçüleri (mm) Dimension (mm)						Kesici Uç Insert	Yedek Parçaları Spare Parts	
		D	Z	d	L	l	a		Sıkma Vidası Screw	Tork Anahtar Torx Key
AEM90-AP16D-D25-W25-L150-Z02	●	25	2	25	150	50	16	AP.. 1604.. DJT UCUNA UYGUNDUR. FOR DJT INSERT.		
AEM90-AP16D-D25-C25-L200-Z02	●	25	2	25	200	50	16			
AEM90-AP16D-D32-W32-L150-Z03	●	32	3	32	150	50	16			
AEM90-AP16D-D32-C32-L180-Z03	●	32	3	32	180	50	16			
AEM90-AP16D-D32-C32-L200-Z03	●	32	3	32	200	50	16	AP.. 1604.. LMN UCUNA UYGUNDUR. FOR LMN INSERT.	1515-M4x9	80-T15
AEM90-AP16L-D25-C25-L120-Z02-H	●	25	2	25	120	45	16			
AEM90-AP16L-D25-C25-L150-Z02	●	25	2	25	150	55	16			
AEM90-AP16L-D25-C25-L200-Z02	●	25	2	25	200	55	16			
AEM90-AP16L-D25-C25-L250-Z02	●	25	2	25	250	100	16			
AEM90-AP16L-D32-C32-L120-Z03-H	●	32	3	32	120	45	16			
AEM90-AP16L-D32-C32-L150-Z03	●	32	3	32	150	55	16			
AEM90-AP16L-D32-C32-L200-Z03	●	32	3	32	200	55	16			
AEM90-AP16L-D32-C32-L250-Z03	●	32	3	32	250	100	16			
AEM90-AP16L-D40-C32-L120-Z04-H	●	40	4	32	120	40	16			
AEM90-AP16L-D40-C32-L150-Z04	●	40	4	32	150	40	16			
AEM90-AP16L-D40-C32-L200-Z04	●	40	4	32	200	40	16			
AEM90-AP16L-D40-C32-L250-Z04	●	40	4	32	250	40	16			
AEM90-AP16P-D25-W25-L100-Z02-H	●	25	2	25	100	35	16	AP.. 1604.. PLBT UCUNA UYGUNDUR. FOR PLBT INSERT.		
AEM90-AP16P-D25-W25-L150-Z02	●	25	2	25	150	50	16			
AEM90-AP16P-D32-W32-L150-Z03	●	32	3	32	150	50	16			
AEM90-AP16P-D32-C32-L250-Z02	●	32	2	32	250	100	16			
AEM90-AP16P-D40-W32-L150-Z04	●	40	4	32	150	50	16			
AEM90-AP1705-D25-C25-L120-Z02	●	25	2	25	120	40	16	AP.. 1705.. TGTC-LMN UCUNA UYGUNDUR. FOR TGTC-LMN INSERT.		
AEM90-AP1705-D26-C25-L200-Z02	●	26	2	25	200	40	16			
AEM90-AP1705-D26-C25-L250-Z02	●	26	2	25	250	40	16			
AEM90-AP1705-D32-C25-L150-Z03	●	32	3	25	150	40	16			
AEM90-AP1705-D33-C32-L300-Z02	●	33	2	32	300	40	16			

R: Sağ/Right L: Sol/Left ● Stokta/In Stock ○ Stokta Yok/Non Stock Item

Sipariş Örneği/Ordering Example : 1 ad./pcs. AEM90-AP16D-D25-W25-L150-Z02
Kesme Hesabı : S 229 / Cutting Calculation : P 229

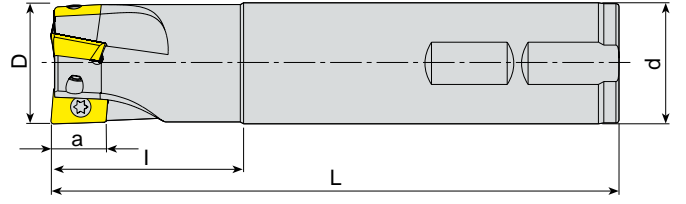

Takım Kodu Ordering Code	Stok Stock	Takım Ölçüleri (mm) Dimension (mm)						Kesici Uç Insert	Yedek Parçaları Spare Parts	
		D	Z	d	L	l	a		Sıkma Vidası Screw	Tork Anahtar Torx Key
AEM90-AX0602-D10-C10-L120-Z02	●	10	2	10	120	20	5.7	AX.. 0602	3006-M1.8x4	80-T06
AEM90-AX0602-D12-C12-L120-Z02	●	12	2	12	120	20	5.7			
AEM90-AX0602-D14-C12-L120-Z03	●	14	3	12	120	20	5.7			
AEM90-AX0602-D16-W16-L120-Z04-H	●	16	4	16	120	20	5.7			
AEM90-AX0602-D16-W16-L150-Z04-H	●	16	4	16	150	20	5.7			
AEM90-AX0602-D20-W20-L120-Z05-H	●	20	5	20	120	25	5.7			
AEM90-AX0602-D20-W20-L150-Z05-H	●	20	5	20	150	25	5.7	AX.. 0903	3008-M2.5x5	80-T08
AEM90-AX0903-D16-C16-L120-Z02	●	16	2	16	120	30	8.8			
AEM90-AX0903-D16-C16-L180-Z02	●	16	2	16	180	30	8.8			
AEM90-AX0903-D17-C16-L120-Z02	●	17	2	16	120	25	8.8			
AEM90-AX0903-D17-C16-L180-Z02	●	17	2	16	180	25	8.8			
AEM90-AX0903-D20-C20-L120-Z03	●	20	3	20	120	30	8.8			
AEM90-AX0903-D20-C20-L200-Z02	●	20	2	20	200	30	8.8			
AEM90-AX0903-D21-C20-L120-Z03	●	21	3	20	120	25	8.8			
AEM90-AX0903-D21-C20-L200-Z02	●	21	2	20	200	25	8.8			
AEM90-AX0903-D25-C25-L150-Z03	●	25	3	25	150	30	8.8			
AEM90-AX0903-D25-C25-L250-Z02	●	25	2	25	250	40	8.8			
AEM90-AX0903-D26-C25-L150-Z03	●	26	3	25	150	30	8.8			

R: Sağ/Right L: Sol/Left ● Stokta/In Stock ○ Stokta Yok/Non Stock Item
TGTC Ucuna Uygunudur. / Compatible with TGTC Insert.

Sipariş Örneği/Ordering Example : 1 ad./pcs. AEM90-AX0602-D10-C10-L120-Z02
Kesme Hesabı : S 229 / Cutting Calculation : P 229



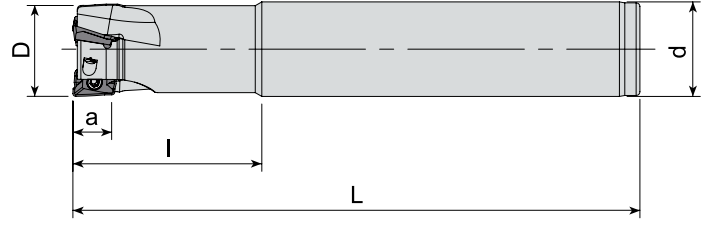

Takım Kodu Ordering Code	Stok Stock	Takım Ölçüleri (mm) Dimension (mm)						Kesici Uç Insert	Yedek Parçaları Spare Parts	
		D	Z	d	L	l	a		Sıkma Vidası Screw	Tork Anahtar Torx Key
AEM90-AX1235-D16-C14-L120-Z02-H	●	16	2	14	120	25	10			
AEM90-AX1235-D16-C16-L140-Z02-H	●	16	2	16	140	25	10			
AEM90-AX1235-D16-C16-L150-Z02	●	16	2	16	150	30	10			
AEM90-AX1235-D20-C20-L150-Z02	●	20	2	20	150	40	10			
AEM90-AX1235-D20-C20-L150-Z03	●	20	3	20	150	40	10			
AEM90-AX1235-D25-C20-L120-Z04-H	●	25	4	20	120	30	10			
AEM90-AX1235-D25-C25-L150-Z03	●	25	3	25	150	50	10			
AEM90-AX1705-D25-C25-L150-Z02	●	25	2	25	150	50	14			
AEM90-AX1705-D32-C32-L150-Z03	●	32	3	32	150	50	14			

SMTM Ucuna Uygundur. / Compatible with SMTM Insert.

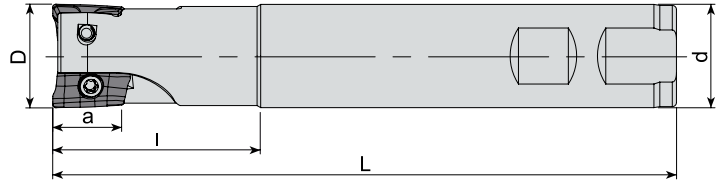

Takım Kodu Ordering Code	Stok Stock	Takım Ölçüleri (mm) Dimension (mm)						Kesici Uç Insert	Yedek Parçaları Spare Parts	
		D	Z	d	L	l	a		Sıkma Vidası Screw	Tork Anahtar Torx Key
AEM90-BD11T3-D16-W16-L100-Z02-H	●	16	2	16	100	30	10			
AEM90-BD11T3-D16-W16-L150-Z02	●	16	2	16	150	50	10			
AEM90-BD11T3-D20-W20-L100-Z03-H	●	20	3	20	100	30	10			
AEM90-BD11T3-D20-W20-L150-Z03	●	20	3	20	150	50	10			
AEM90-BD11T3-D25-W25-L100-Z03-H	●	25	3	25	100	30	10			
AEM90-BD11T3-D25-W25-L150-Z03	●	25	3	25	150	50	10			
AEM90-BD11T3-D32-W32-L110-Z04-H	●	32	4	32	110	40	10			
AEM90-BD11T3-D32-W32-L150-Z04	●	32	4	32	150	50	10			
AEM90-BD1704-D25-W25-L100-Z02-H	●	25	2	25	100	35	15.7			
AEM90-BD1704-D25-W25-L150-Z02	●	25	2	25	150	50	15.7			
AEM90-BD1704-D32-W32-L110-Z03-H	●	32	3	32	110	40	15.7			
AEM90-BD1704-D32-W32-L150-Z03	●	32	3	32	150	50	15.7			
AEM90-BD1704-D40-W32-L110-Z04-H	●	40	4	32	110	40	15.7			
AEM90-BD1704-D40-W32-L150-Z04	●	40	4	32	150	40	15.7			

R: Sağ/Right L: Sol/Left ● Stokta/In Stock ○ Stokta Yok/Non Stock Item
KYCR Ucuna Uygundur. / Compatible with KYCR Insert.

Sipariş Örneği/Ordering Example : 1 ad./pcs. AEM90-AX1235-D16-C14-L120-Z02-H
Kesme Hesabı : S 229 / Cutting Calculation : P 229

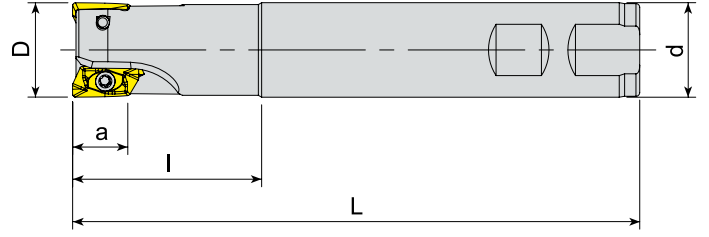

Takım Kodu Ordering Code	Stok Stock	Takım Ölçüleri (mm) Dimension (mm)						Kesici Uç Insert	Yedek Parçaları Spare Parts	
		D	Z	d	L	l	a		Sıkma Vidası Screw	Tork Anahtar Torx Key
AEM90-ED1404-D20-W20-L150-Z02	●	20	2	20	150	50	14.5	EDPT 1404..	1008-M3x6	80-T08
AEM90-ED1404-D25-W25-L150-Z02	●	25	2	25	150	50	14.5			

KNMTL Ucuna Uygunur. / Compatiple with KNMTL Insert.

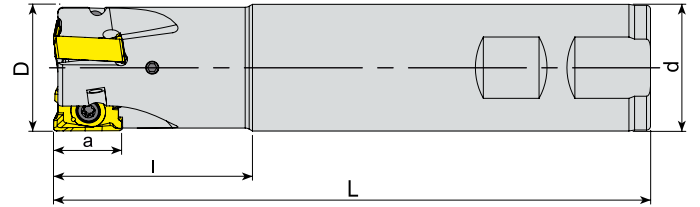



Takım Kodu Ordering Code	Stok Stock	Takım Ölçüleri (mm) Dimension (mm)						Kesici Uç Insert	Yedek Parçaları Spare Parts	
		D	Z	d	L	l	a		Sıkma Vidası Screw	Tork Anahtar Torx Key
AEM90-LN15T6-D25-W25-L150-Z02-H	●	25	2	25	150	50	15.5	LNGU 15T6..	4015-M4x12	80-T15
AEM90-LN15T6-D32-W32-L150-Z03-H	●	32	3	32	150	50	15.5			
AEM90-LN15T6-D40-W32-L150-Z03-H	●	40	3	32	150	40	15.5			

R: Sağ/Right L: Sol/Left ● Stokta/In Stock ○ Stokta Yok/Non Stock Item
KNMTL Ucuna Uygunur. / Compatiple with KNMTL Insert.

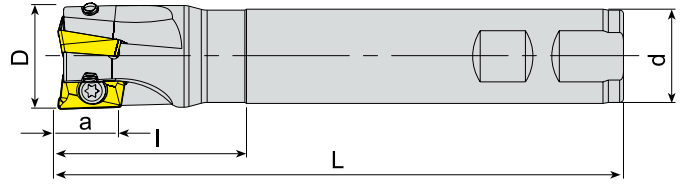
Sipariş Örneği/Ordering Example : 1 ad./pcs. AEM90-ED1404-D20-W20-L150-Z02
Kesme Hesabı : S 229 / Cutting Calculation : P 229

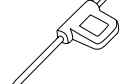

Takım Kodu Ordering Code	Stok Stock	Takım Ölçüleri (mm) Dimension (mm)						Kesici Uç Insert	Yedek Parçaları Spare Parts	
		D	Z	d	L	l	a		Sıkma Vidası Screw	Tork Anahtar Torx Key
AEM90-R390.11-D16-W16-L100-Z02-H	●	16	2	16	100	30	10			
AEM90-R390.11-D16-W16-L150-Z02	●	16	2	16	150	50	10			
AEM90-R390.11-D16-W16-L150-Z02-H	●	16	2	16	150	50	10			
AEM90-R390.11-D20-W20-L090-Z02-H	●	20	2	20	90	30	10			
AEM90-R390.11-D20-W20-L100-Z03-H	●	20	3	20	100	30	10			
AEM90-R390.11-D20-W20-L150-Z03	●	20	3	20	150	50	10			
AEM90-R390.11-D20-W20-L150-Z03-H	●	20	3	20	150	50	10			
AEM90-R390.11-D22-W20-L090-Z02-H	●	22	2	20	90	30	10			
AEM90-R390.11-D25-W25-L100-Z03-H	●	25	3	25	100	30	10			
AEM90-R390.11-D25-W25-L150-Z03	●	25	3	25	150	50	10			
AEM90-R390.11-D25-W25-L150-Z03-H	●	25	3	25	150	50	10			
AEM90-R390.11-D30-W25-L150-Z04-H	●	30	4	25	150	30	10			
AEM90-R390.11-D32-W32-L150-Z05-H	●	32	5	32	150	50	10			
AEM90-R390.17-D25-W25-L150-Z02	●	25	2	25	150	50	15.4			
AEM90-R390.17-D25-W25-L150-Z02-H	●	25	2	25	150	50	15.4			
AEM90-R390.17-D30-W25-L150-Z03	●	30	3	25	150	40	15.4			
AEM90-R390.17-D30-W25-L150-Z03-H	●	30	3	25	150	40	15.4			

R: Sağ/Right L: Sol/Left ● Stokta/In Stock ○ Stokta Yok/Non Stock Item
SNDVK Ucuna Uygunudur. / Compatible with SNDVK Insert.

Sipariş Örneği/Ordering Example : 1 ad./pcs. AEM90-R390.11-D16-W16-L100-Z02-H
Kesme Hesabı : S 229 / Cutting Calculation : P 229



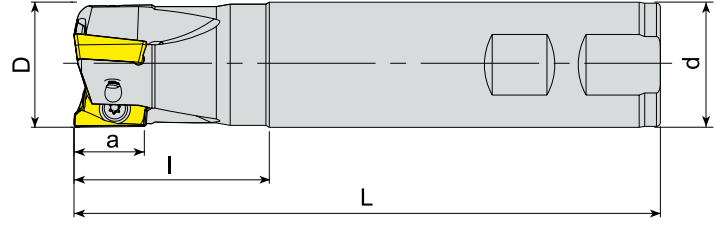

Takım Kodu Ordering Code	Stok Stock	Takım Ölçüleri (mm) Dimension (mm)						Kesici Uç Insert	Yedek Parçaları Spare Parts	
		D	Z	d	L	l	a		Sıkma Vidası Screw	Tork Anahtar Torx Key
AEM90-RT07-D10-W10-L120-Z02	●	10	2	10	120	30	7	RT 0702	3006-M2x4	80-T06
AEM90-RT07-D12-W12-L120-Z02	●	12	2	12	120	30	7			
AEM90-RT07-D12-C12-L120-Z02	●	12	2	12	120	30	7			
AEM90-RT07-D14-W12-L120-Z02	●	14	2	12	120	30	7			
AEM90-RT10-D16-W16-L120-Z02-H	●	16	2	16	120	30	10	RT 1003	3008-M2.5x6	80-T08
AEM90-RT10-D16-W16-L150-Z02	●	16	2	16	150	50	10			
AEM90-RT10-D16-C15-L160-Z02	●	16	2	15	160	30	10			
AEM90-RT10-D16-C16-L200-Z02	●	16	2	16	200	100	10			
AEM90-RT10-D17-W16-L160-Z02	●	17	2	16	160	30	10			
AEM90-RT10-D18-W16-L120-Z02-H	●	18	2	16	120	30	10			
AEM90-RT10-D20-W20-L120-Z03-H	●	20	3	20	120	30	10			
AEM90-RT10-D20-W20-L150-Z03	●	20	3	20	150	50	10			
AEM90-RT10-D20-C19-L200-Z03	●	20	3	19	200	30	10			
AEM90-RT10-D20-C20-L200-Z03	●	20	3	20	200	100	10			
AEM90-RT10-D21-W20-L200-Z03	●	21	3	20	200	30	10			
AEM90-RT10-D22-W20-L120-Z03-H	●	22	3	20	120	30	10			
AEM90-RT10-D22-C20-L150-Z03	●	22	3	20	150	30	10			
AEM90-RT10-D22-C20-L200-Z03	●	22	3	20	200	30	10			
AEM90-RT10-D25-W25-L120-Z04-H	●	25	4	25	120	40	10			
AEM90-RT10-D25-W25-L150-Z04	●	25	4	25	150	50	10			
AEM90-RT10-D25-C25-L200-Z04	●	25	4	25	200	100	10			
AEM90-RT10-D32-W32-L120-Z05-H	●	32	5	32	120	50	10			
AEM90-RT10-D32-W32-L150-Z05	●	32	5	32	150	50	10			
AEM90-RT10-D32-C32-L200-Z05	●	32	5	32	200	100	10			
AEM90-RT13-D32-C32-L250-Z04	●	32	4	32	250	50	13	RT 1304	1008-M3x8	
AEM90-RT16-D25-W25-L120-Z02-H	●	25	2	25	120	40	16	RT 1606	1515-M4x9	80-T15
AEM90-RT16-D25-W25-L150-Z02	●	25	2	25	150	50	16			
AEM90-RT16-D25-C25-L200-Z02	●	25	2	25	200	100	16			
AEM90-RT16-D32-W32-L120-Z03-H	●	32	3	32	120	50	16			
AEM90-RT16-D32-W32-L150-Z03	●	32	3	32	150	50	16			
AEM90-RT16-D32-C32-L200-Z03	●	32	3	32	200	100	16			
AEM90-RT16-D32-C32-L250-Z03	●	32	3	32	250	100	16			
AEM90-RT16-D32-C32-L270-Z03	●	32	3	32	270	100	16			
AEM90-RT16-D40-W32-L120-Z04-H	●	40	4	32	120	50	16			
AEM90-RT16-D40-W32-L150-Z04	●	40	4	32	150	50	16			
AEM90-RT16-D40-C32-L200-Z04	●	40	4	32	200	100	16			

R: Sağ/Right L: Sol/Left ● Stokta/In Stock ○ Stokta Yok/Non Stock Item
SFTY Ucuna Uygunudur. / Compatible with SFTY Insert.

Sipariş Örneği/Ordering Example : 1 ad./pcs. AEM90-RT07-D10-W10-L120-Z02
Kesme Hesabı : S 229 / Cutting Calculation : P 229

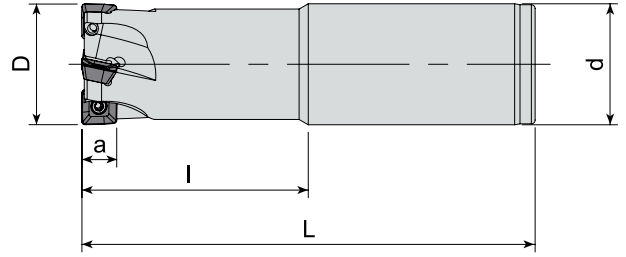

Takım Kodu Ordering Code	Stok Stock	Takım Ölçüleri (mm) Dimension (mm)						Kesici Uç Insert	Yedek Parçaları Spare Parts	
		D	Z	d	L	l	a		Sıkma Vidası Screw	Tork Anahtar Torx Key
AEM90-SE09-D25-C25-L120-Z03-H	●	25	3	25	120	60	6.7			
AEM90-SE09-D25-C25-L150-Z02	●	25	2	25	150	50	6.7			
AEM90-SE09-D32-C32-L120-Z04-H	●	32	4	32	120	60	6.7			
AEM90-SE09-D32-C32-L150-Z03	●	32	3	32	150	50	6.7			

ZCC Ucuna Uygundur. / Compatible with ZCC Insert.

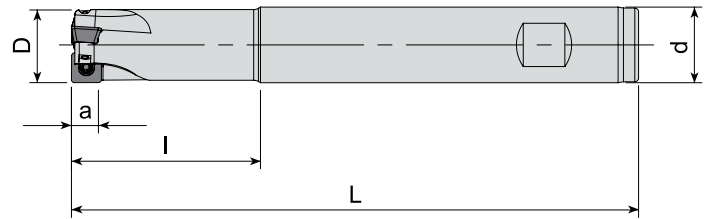

Takım Kodu Ordering Code	Stok Stock	Takım Ölçüleri (mm) Dimension (mm)						Kesici Uç Insert	Yedek Parçaları Spare Parts	
		D	Z	d	L	l	a		Sıkma Vidası Screw	Tork Anahtar Torx Key
AEM90-SPGT0602-D16-W16-L150-Z02	●	16	2	16	150	50	5.5			
AEM90-SPGT07T3-D20-W20-L150-Z03	●	20	3	20	150	50	7			
AEM90-SPGT07T3-D25-W25-L150-Z03	●	25	3	25	150	50	7			
AEM90-SPGT0904-D30-W32-L150-Z03	●	30	3	32	150	50	9			

R: Sağ/Right L: Sol/Left ●Stokta/In Stock ○Stokta Yok/Non Stock Item
ZCC Ucuna Uygundur. / Compatible with ZCC Insert.

Sipariş Örneği/Ordering Example : 1 ad./pcs. AEM90-SE09-D25-C25-L120-Z03-H
Kesme Hesabı : S 229 / Cutting Calculation : P 229

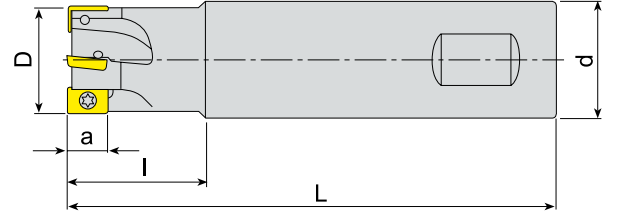

Takım Kodu Ordering Code	Stok Stock	Takım Ölçüleri (mm) Dimension (mm)						Kesici Uç Insert	Yedek Parçaları Spare Parts	
		D	Z	d	L	l	a		Sıkma Vidası Screw	Tork Anahtar Torx Key
AEM90-XC13-D20-W20-L150-Z02	●	20	2	20	150	60	13	XCKX 13T3..	1008-M3x6	80-T08
AEM90-XC13-D25-W25-L150-Z03	●	25	3	25	150	60	13		1008-M3x8	
AEM90-XC13-D32-W32-L150-Z04	●	32	4	32	150	60	13			

SC Ucuna Uygun. / Compatiple with SC Insert.

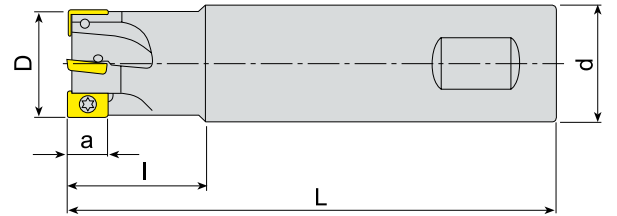

Takım Kodu Ordering Code	Stok Stock	Takım Ölçüleri (mm) Dimension (mm)						Kesici Uç Insert	Yedek Parçaları Spare Parts	
		D	Z	d	L	l	a		Sıkma Vidası Screw	Tork Anahtar Torx Key
AEM90-XD11T3-D16-W16-L150-Z02	●	16	2	16	150	30	10	XD.T 11T3..	3008-M2.5x6	80-T08
AEM90-XD11T3-D17-C16-L150-Z02	●	17	2	16	150	30	10			
AEM90-XD11T3-D20-W20-L150-Z03	●	20	3	20	150	50	10			
AEM90-XD11T3-D21-C20-L150-Z03	●	21	3	20	150	30	10			
AEM90-XD11T3-D25-W25-L150-Z04	●	25	4	25	150	50	10			
AEM90-XD11T3-D32-W32-L150-Z04	●	32	4	32	150	50	10			

R: Sağ/Right L: Sol/Left ● Stokta/In Stock ○ Stokta Yok/Non Stock Item
CRTZT Ucuna Uygun. / Compatiple with CRTZT Insert.

Sipariş Örneği/Ordering Example : 1 ad./pcs. AEM90-XC13-D20-W20-L150-Z02
Kesme Hesabı : S 229 / Cutting Calculation : P 229

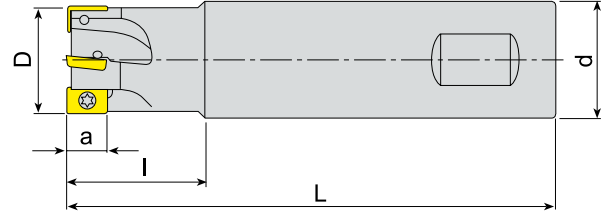

Takım Kodu Ordering Code	Stok Stock	Takım Ölçüleri (mm) Dimension (mm)						Kesici Uç Insert	Yedek Parçaları Spare Parts	
		D	Z	d	L	l	a		Sıkma Vidası Screw	Tork Anahtar Torx Key
AEM90-X006-D10-C12-L120-Z02	●	10	2	12	120	50	5		3006-M1.8x4	80-T06
AEM90-X006-D12-C12-L120-Z02	●	12	2	12	120	25	5			
AEM90-X009-D16-W16-L150-Z02	●	16	2	16	150	50	8		3008-M2.5x5	80-T08
AEM90-X009-D20-W20-L150-Z03	●	20	3	20	150	50	8			
AEM90-X012-D20-W20-L150-Z02	●	20	2	20	150	50	11		1510-M3.5x7	80-T10
AEM90-X012-D20-C20-L200-Z02	●	20	2	20	200	100	11			
AEM90-X012-D22-W20-L150-Z02	●	22	2	20	150	30	11			
AEM90-X012-D25-W25-L150-Z03	●	25	3	25	150	50	11			
AEM90-X012-D25-C25-L200-Z03	●	25	3	25	200	100	11			
AEM90-X012-D32-C25-L150-Z04	●	32	4	25	150	40	11			
AEM90-X012-D32-W32-L150-Z04	●	32	4	32	150	50	11			
AEM90-X012-D32-C32-L250-Z04	●	32	4	32	250	100	11			

SC Ucuna Uygunudur. / Compatible with SC Insert.

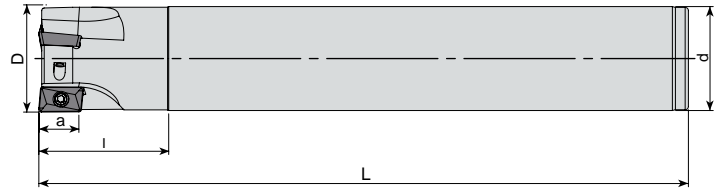



Takım Kodu Ordering Code	Stok Stock	Takım Ölçüleri (mm) Dimension (mm)						Kesici Uç Insert	Yedek Parçaları Spare Parts	
		D	Z	d	L	l	a		Sıkma Vidası Screw	Tork Anahtar Torx Key
AEM90-ZP13T3-D26-C25-L200-Z02	●	26	2	25	200	35	13		4010-M3x8	80-T10
AEM90-ZP13T3-D26-C25-L200-Z03	●	26	3	25	200	35	13			
AEM90-ZP13T3-D26-C25-L250-Z02	●	26	2	25	250	35	13			
AEM90-ZP13T3-D33-C32-L200-Z03	●	33	3	32	200	40	13			
AEM90-ZP13T3-D33-C32-L250-Z03	●	33	3	32	250	40	13			

R: Sağ/Right L: Sol/Left ● Stokta/In Stock ○ Stokta Yok/Non Stock Item
DJT Ucuna Uygunudur. / Compatible with DJT Insert.

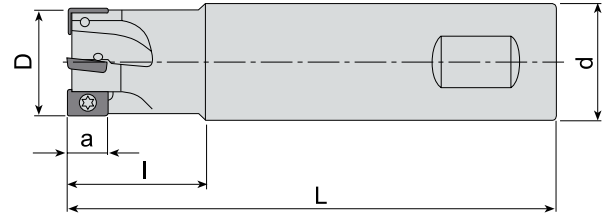



Sipariş Örneği/Ordering Example : 1 ad./pcs. AEM90-X006-D10-C12-L120-Z02
Kesme Hesabı : S 229 / Cutting Calculation : P 229

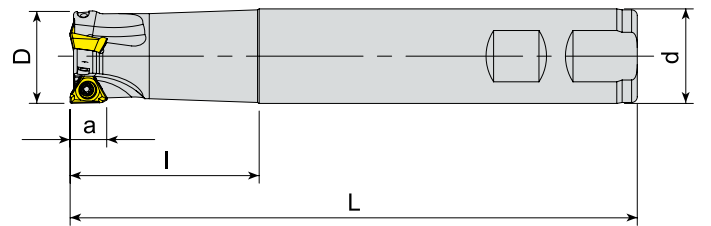

Takım Kodu Ordering Code	Stok Stock	Takım Ölçüleri (mm) Dimension (mm)						Kesici Uç Insert	Yedek Parçaları Spare Parts	
		D	Z	d	L	l	a		Sıkma Vidası Screw	Tork Anahtar Torx Key
AEM90-ZC1003-D16-C14-L150-Z02	●	16	2	14	150	25	9			
AEM90-ZC1003-D16-C15-L150-Z02	●	16	2	15	150	25	9			
AEM90-ZC1003-D16-C16-L150-Z02	●	16	2	16	150	25	9			
AEM90-ZC1003-D17-C16-L150-Z02	●	17	2	16	150	25	9			
AEM90-ZC1003-D17-C16-L200-Z02	●	17	2	16	200	25	9			
AEM90-ZC1003-D20-C18-L150-Z03	●	20	3	18	150	25	9			
AEM90-ZC1003-D20-C20-L150-Z03	●	20	3	20	150	40	9			
AEM90-ZC1003-D20-C18-L200-Z03	●	20	3	18	200	25	9			
AEM90-ZC1003-D21-C20-L150-Z03	●	21	3	20	150	30	9			
AEM90-ZC1003-D21-C20-L200-Z03	●	21	3	20	200	30	9			
AEM90-ZC1003-D25-C20-L150-Z03	●	25	3	20	150	30	9			
AEM90-ZC1003-D25-C25-L150-Z03	●	25	3	25	150	40	9			
AEM90-ZC1003-D26-C25-L170-Z03	●	26	3	25	170	25	9			
AEM90-ZC1003-D26-C25-L200-Z03	●	26	3	25	200	25	9			
AEM90-ZC1003-D32-C25-L180-Z04	●	32	4	25	180	30	9			
AEM90-ZC1003-D33-C32-L200-Z04	●	33	4	32	200	25	9			

DJT Ucuna Uygundur. / Compatible with DJT Insert.

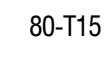

Takım Kodu Ordering Code	Stok Stock	Takım Ölçüleri (mm) Dimension (mm)						Kesici Uç Insert	Yedek Parçaları Spare Parts	
		D	Z	d	L	l	a		Sıkma Vidası Screw	Tork Anahtar Torx Key
AEM90-3P1004-D20-W20-L150-Z02	●	20	2	20	150	40	7			
AEM90-3P1004-D25-W25-L150-Z03	●	25	3	25	150	40	7			
AEM90-3P1505-D32-W32-L150-Z03	●	32	3	32	150	50	11			
AEM90-3P1505-D40-W32-L150-Z04	●	40	4	32	150	35	11			

R: Sağ/Right L: Sol/Left ● Stokta/In Stock ○ Stokta Yok/Non Stock Item
TGTC Ucuna Uygundur. / Compatible with TGTC Insert.

Sipariş Örneği/Ordering Example : 1 ad./pcs. AEM90-ZC1003-D16-C14-L150-Z02
Kesme Hesabı : S 229 / Cutting Calculation : P 229

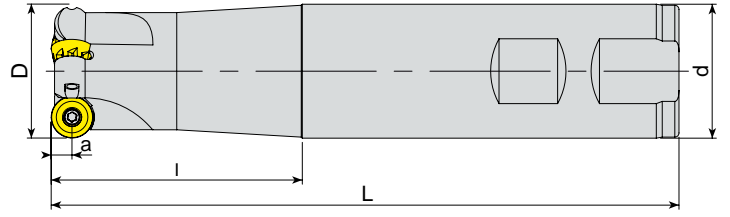

Takım Kodu Ordering Code	Stok Stock	Takım Ölçüleri (mm) Dimension (mm)					Kesici Uç Insert	Yedek Parçaları Spare Parts				
		D	Z	d	L	l		a	Sıkma Vidası Screw	Baskı Parçası Wedge Clamp	Baskı Vidası Clamp Screw	Tork Anahtar Torx Key
AEMR-RP10T3-D25-W25-L150-Z02	●	25	2	25	150	60	5	RPNX 10T3..				
AEMR-RP10T3-D32-W32-L150-Z03	●	32	3	32	150	60	5					

CRTZT Ucuna Uygundur. / Compatible with CRTZT Insert.

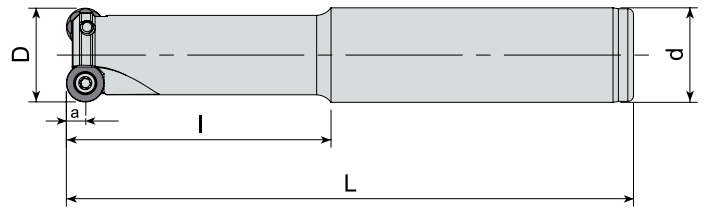

Takım Kodu Ordering Code	Stok Stock	Takım Ölçüleri (mm) Dimension (mm)					Kesici Uç Insert	Yedek Parçaları Spare Parts				
		D	Z	d	L	l		a	Sıkma Vidası Screw	Baskı Parçası Wedge Clamp	Baskı Vidası Clamp Screw	Tork Anahtar Torx Key
AEMR-QP10T3-D20-C20-L150-Z01-H	●	20	1	20	150	70	5	QP.. 10T3..				
AEMR-QP10T3-D25-C25-L150-Z02-H	●	25	2	25	150	70	5					
AEMR-QP10T3-D25-C25-L170-Z02	●	25	2	25	170	90	5					
AEMR-QP10T3-D32-C32-L150-Z03-H	●	32	3	32	150	70	5					
AEMR-QP10T3-D32-C32-L170-Z03	●	32	3	32	170	90	5					
AEMR-QP1204-D25-C25-L150-Z02-H	●	25	2	25	150	70	6	QP.. 1204..	1515-M4x9	-	-	

R: Sağ/Right L: Sol/Left ● Stokta/In Stock ○ Stokta Yok/Non Stock Item
SMTM Ucuna Uygundur. / Compatible with SMTM Insert.

Sipariş Örneği/Ordering Example : 1 ad./pcs. AEMR-RP10T3-D25-W25-L150-Z02
Kesme Hesabı : S 229 / Cutting Calculation : P 229

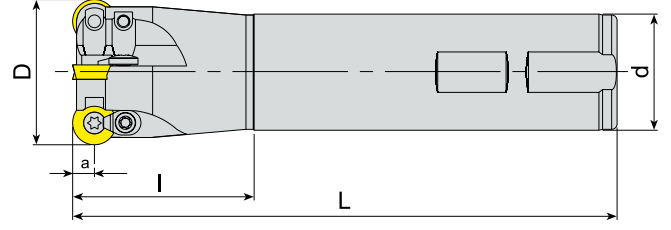

Takım Kodu Ordering Code	Stok Stock	Takım Ölçüleri (mm) Dimension (mm)						Kesici Uç Insert	Yedek Parçaları Spare Parts								
		D	Z	d	L	l	a		Sıkma Vidası Screw	Baskı Parçası Wedge Clamp	Baskı Vidası Clamp Screw	Tork Anahtar Torx Key					
AEMR-RD0501-D08-W10-L100-Z01-H	●	8	1	10	100	20	2.5	RD.. 0501	3006-M2x3.6			80-T06					
AEMR-RD0501-D10-W12-L100-Z02-H	●	10	2	12	100	20	2.5						3006-M2x4				
AEMR-RD0501-D12-W12-L120-Z02-H	●	12	2	12	120	20	2.5										
AEMR-RD0803-D16-W16-L150-Z02	●	16	2	16	150	60	4	RD.. 0803	1008-M3x6	-	-	80-T08					
AEMR-RD0803-D16-C20-L200-Z02	●	16	2	20	200	60	4										
AEMR-RD08T2-D16-W16-L150-Z02	●	16	2	16	150	60	4	RD.. 08T2	3008-M2.5x6								
AEMR-RD08T2-D20-W20-L150-Z02	●	20	2	20	150	60	4										
AEMRC-RD1003-D20-W20-L150-Z02	●	20	2	20	150	60	5	RD.. 1003									
AEMRC-RD1003-D20-C20-L160-Z02	●	20	2	20	160	70	5										
AEMRC-RD1003-D20-C20-L250-Z02	●	20	2	20	250	150	5										
AEMRC-RD1003-D21-C20-L160-Z02	●	21	2	20	160	70	5										
AEMRC-RD1003-D25-W25-L150-Z02	●	25	2	25	150	60	5										
AEMRC-RD1003-D25-C25-L160-Z02	●	25	2	25	160	70	5										
AEMRC-RD1003-D25-W25-L200-Z02	●	25	2	25	200	100	5										
AEMRC-RD1003-D25-C25-L200-Z02	●	25	2	25	200	100	5										
AEMRC-RD1003-D25-C25-L250-Z02	●	25	2	25	250	150	5										
AEMRC-RD1003-D26-C25-L160-Z02	●	26	2	25	160	70	5										
AEMRC-RD1003-D32-W32-L150-Z03	●	32	3	32	150	60	5										
AEMRC-RD1003-D32-C32-L250-Z02	●	32	2	32	250	150	5										
AEMRC-RD1003-D33-C32-L160-Z03	●	33	3	32	160	70	5										
AEMRC-RD1003-D40-W32-L150-Z04	●	40	4	32	150	35	5										
AEMRC-RD1003-D40-C32-L250-Z02	●	40	2	32	250	35	5										
AEMRC-RD10T3-D20-W20-L150-Z02	●	20	2	20	150	60	5						RD.. 10T3	4015-M3.5x9	ACK-15	1015-M3.5x11	80-T15
AEMRC-RD10T3-D25-W25-L150-Z02	●	25	2	25	150	60	5										
AEMRC-RD10T3-D32-W32-L150-Z03	●	32	3	32	150	60	5	RD.. 1204									
AEMRC-RD1204-D32-C32-L160-Z03	●	32	3	32	160	70	6										
AEMRC-RD1204-D32-W32-L160-Z03	●	32	3	32	160	50	6	RD.. 12T3									
AEMRC-RD1204-D33-C32-L160-Z03	●	33	3	32	160	70	6										
AEMRC-RD12T3-D25-W25-L150-Z02	●	25	2	25	150	60	6	RD.. 12T3									
AEMRC-RD12T3-D25-W25-L200-Z02	●	25	2	25	200	100	6										
AEMRC-RD12T3-D25-C25-L250-Z02	●	25	2	25	250	150	6										
AEMRC-RD12T3-D32-W32-L150-Z03	●	32	3	32	150	60	6										
AEMRC-RD12T3-D32-C32-L250-Z02	●	32	2	32	250	150	6										
AEMRC-RD12T3-D40-W32-L150-Z04	●	40	4	32	150	50	6										
AEMRC-RD12T3-D40-C32-L250-Z02	●	40	2	32	250	50	6	RD.. 1604	1515-M4.5x11	ACK-05	1515-M4x11						
AEMRC-RD1604-D40-W32-L150-Z02	●	40	2	32	150	35	8										

R: Sağ/Right L: Sol/Left ● Stokta/In Stock ○ Stokta Yok/Non Stock Item
ISO Ucuna Uygundur. / Compatible with ISO Insert.

Sipariş Örneği/Ordering Example : 1 ad./pcs. AEMR-RD0501-D08-W10-L100-Z01-H
Kesme Hesabı : S 229 / Cutting Calculation : P 229

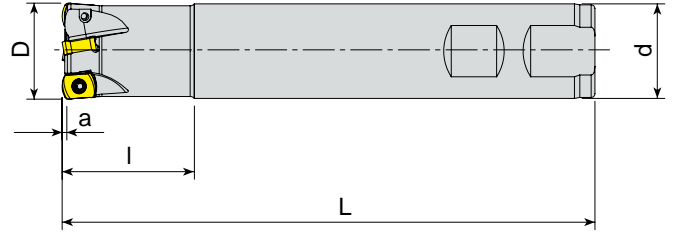

Takım Kodu Ordering Code	Stok Stock	Takım Ölçüleri (mm) Dimension (mm)						Kesici Uç Insert	Yedek Parçaları Spare Parts	
		D	Z	d	L	l	a		Sıkma Vidası Screw	Tork Anahtar Torx Key
AHFM-BL0603-D17-W16-L170-Z02	●	17	2	16	170	20	1	BLMP 0603R	3008-M2.5x6	80-T08
AHFM-BL0603-D21-W20-L200-Z03	●	21	3	20	200	25	1			
AHFM-BL0603-D26-W25-L200-Z04	●	26	4	25	200	35	1			

TGTC Ucuna Uygundur. / Compatible with TGTC Insert.

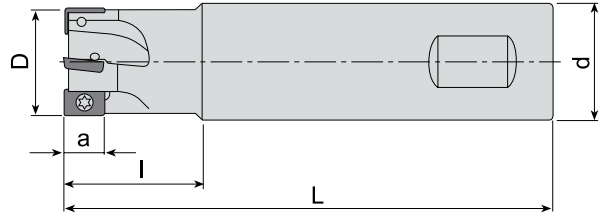

Takım Kodu Ordering Code	Stok Stock	Takım Ölçüleri (mm) Dimension (mm)						Kesici Uç Insert	Yedek Parçaları Spare Parts	
		D	Z	d	L	l	a		Sıkma Vidası Screw	Tork Anahtar Torx Key
AHFM-E00602-D10-C10-L080-Z02	●	10	2	10	80	20	-	EOMW 060210	3006-M1.8x4	80-T06
AHFM-E00602-D10-C09-L120-Z02	●	10	2	9	120	15	-			
AHFM-E00602-D10-C10-L120-Z02	●	10	2	10	120	60	-			
AHFM-E00602-D12-C12-L080-Z03	●	12	3	12	80	20	-			
AHFM-E00602-D12-C11-L120-Z02	●	12	2	11	120	15	-			
AHFM-E00602-D12-C11-L120-Z03	●	12	3	11	120	15	-			
AHFM-E00602-D12-C12-L120-Z03	●	12	3	12	120	60	-			
AHFM-E00602-D16-C16-L150-Z04	●	16	4	16	150	60	-			

R: Sağ/Right L: Sol/Left ● Stokta/In Stock ○ Stokta Yok/Non Stock Item
DJT Ucuna Uygundur. / Compatible with DJT Insert.

Sipariş Örneği/Ordering Example : 1 ad./pcs. AHFM-BL0603-D17-W16-L170-Z02
Kesme Hesabı : S 229 / Cutting Calculation : P 229

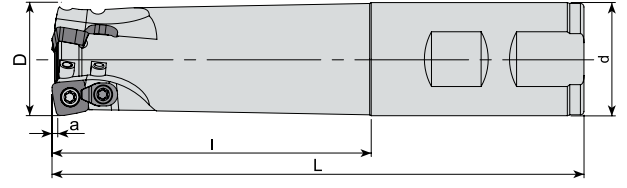

Takım Kodu Ordering Code	Stok Stock	Takım Ölçüleri (mm) Dimension (mm)						Kesici Uç Insert	Yedek Parçaları Spare Parts			
		D	Z	d	L	l	a		Sıkma Vidası Screw	Baskı Parçası Wedge Clamp	Baskı Vidası Clamp Screw	Tork Anahtar Torx Key
AHFMC-SD09T3-D25-C25-L150-Z02	●	25	2	25	150	100	1.4	SD.. 09T3..				
AHFMC-SD09T3-D25-W25-L150-Z02	●	25	2	25	150	100	1.4					
AHFMC-SD09T3-D32-C32-L150-Z03	●	32	3	32	150	100	1.4					
AHFMC-SD09T3-D32-W32-L150-Z03	●	32	3	32	150	100	1.4					

ZCC Ucuna Uygunur. / Compatible with ZCC Insert.

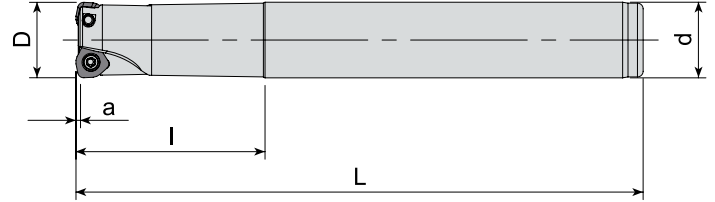

Takım Kodu Ordering Code	Stok Stock	Takım Ölçüleri (mm) Dimension (mm)						Kesici Uç Insert	Yedek Parçaları Spare Parts			
		D	Z	d	L	l	a		Sıkma Vidası Screw	Baskı Parçası Wedge Clamp	Baskı Vidası Clamp Screw	Tork Anahtar Torx Key
AHFM-WD0503D-D20-C20-L150-Z02	●	20	2	20	150	50	1.2	WDMT 0503..				
AHFM-WD0503D-D21-C20-L150-Z02	●	21	2	20	150	30	1.2					
AHFMC-WD06T3D-D26-C25-L200-Z02	●	26	2	25	200	30	1.5	WDHW 06T3..				
AHFMC-WD06T3D-D33-C32-L200-Z03	●	33	3	32	200	32	1.5					

R: Sağ/Right L: Sol/Left ● Stokta/In Stock ○ Stokta Yok/Non Stock Item
DJT Ucuna Uygunur. / Compatible with DJT Insert.

Sipariş Örneği/Ordering Example : 1 ad./pcs. AHFMC-SD09T3-D25-C25-L150-Z02
Kesme Hesabı : S 229 / Cutting Calculation : P 229

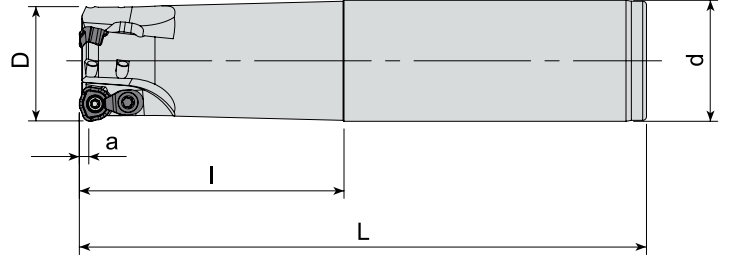

Takım Kodu Ordering Code	Stok Stock	Takım Ölçüleri (mm) Dimension (mm)						Kesici Uç Insert	Yedek Parçaları Spare Parts			
		D	Z	d	L	l	a		Sıkma Vidası Screw	Baskı Parçası Wedge Clamp	Baskı Vidası Clamp Screw	Tork Anahtar Torx Key
AHFM-WD0603-D20-C20-L150-Z03	●	20	3	20	150	70	2			-	-	
AHFMC-WD0804-D25-C25-L150-Z02	●	25	2	25	150	70	2.5			ACK-15	4010-M3x8	
AHFMC-WD0804-D32-C32-L150-Z03	●	32	3	32	150	70	2.5			ACK-05	1515-M4x11	
AHFMC-WD1205-D32-C32-L150-Z02	●	32	2	32	150	70	3			ACK-05	1515-M4x11	

SMTM Ucuna Uygun. / Compatible with SMTM Insert.

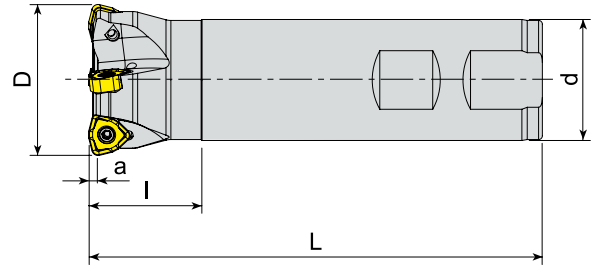

Takım Kodu Ordering Code	Stok Stock	Takım Ölçüleri (mm) Dimension (mm)						Kesici Uç Insert	Yedek Parçaları Spare Parts	
		D	Z	d	L	l	a		Sıkma Vidası Screw	Tork Anahtar Torx Key
AHFM-WN09T3-D25-W25-L120-Z02-H	●	25	2	25	120	40	1.5			
AHFML-WN09T3-D25-W25-L120-Z02-H	●	25	2	25	120	40	1.5			
AHFM-WN09T3-D25-C25-L200-Z02	●	25	2	25	200	120	1.5			
AHFM-WN09T3-D30-W25-L120-Z03-H	●	30	3	25	120	30	1.5			
AHFM-WN09T3-D40-W32-L120-Z04-H	●	40	4	32	120	30	1.5			
AHFM-WN09T3-D40-C32-L200-Z04	●	40	4	32	200	30	1.5			

R: Sağ/Right L: Sol/Left ● Stokta/In Stock ○ Stokta Yok/Non Stock Item
KRLY Ucuna Uygun. / Compatible with KRLY Insert.

Sipariş Örneği/Ordering Example : 1 ad./pcs. AHFM-WD0603-D20-C20-L150-Z03
Kesme Hesabı : S 229 / Cutting Calculation : P 229

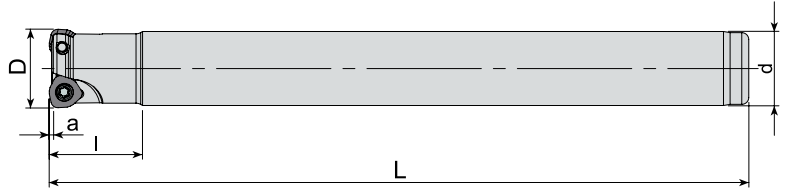

Takım Kodu Ordering Code	Stok Stock	Takım Ölçüleri (mm) Dimension (mm)						Kesici Uç Insert	Yedek Parçaları Spare Parts	
		D	Z	d	L	l	a		Sıkma Vidası Screw	Tork Anahtar Torx Key
AHFM-W004T2D-D16-C16-L150-Z02	●	16	2	16	150	20	-	WOMW 04T2..	3008-M2.5x6	80-T08
AHFM-W004T2D-D17-C16-L150-Z02	●	17	2	16	150	20	-			

R: Sağ/Right L: Sol/Left ● Stokta/In Stock ○ Stokta Yok/Non Stock Item
DJT Ucuna Uygunudur. / Compatiple with DJT Insert.

Sipariş Örneği/Ordering Example : 1 ad./pcs. AHFM-W004T2D-D16-C16-L150-Z02
Kesme Hesabı : S 229 / Cutting Calculation : P 229



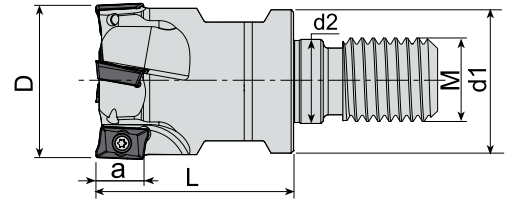

Takım Kodu Ordering Code	Stok Stock	Takım Ölçüleri (mm) Dimension (mm)							Kesici Uç Insert	Yedek Parçaları Spare Parts	
		D	Z	d1	M	L	d2	a		Sıkma Vidası Screw	Tork Anahtar Torx Key
AEM90-AD1505D-D25-M12-L43-Z02-H	●	25	2	21	M12	43	12.5	14.3	ADKT 150508	1515-M4x9	80-T15
AEM90-AD1505D-D32-M16-L43-Z03-H	●	32	3	29	M16	43	17	14.3		1515-M4x11	

DJT Ucuna Uygundur. / Compatible with DJT Insert.

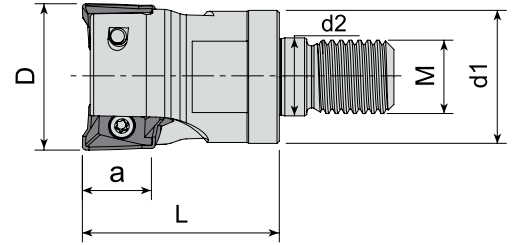

Takım Kodu Ordering Code	Stok Stock	Takım Ölçüleri (mm) Dimension (mm)							Kesici Uç Insert	Yedek Parçaları Spare Parts	
		D	Z	d1	M	L	d2	a		Sıkma Vidası Screw	Tork Anahtar Torx Key
AEM90-AX1235-D16-M08-L30-Z02-H	●	16	2	14.75	M08	30	8.5	10	AX.T 1235..	1008-M3x6	80-T08
AEM90-AX1235-D20-M10-L30-Z03-H	●	20	3	18	M10	30	10.5	10			
AEM90-AX1235-D25-M12-L35-Z04-H	●	25	4	21	M12	35	12.5	10	AX.T 1705..	1515-M4x9	80-T15
AEM90-AX1705-D25-M12-L43-Z02-H	●	25	2	21	M12	43	12.5	14			
AEM90-AX1705-D32-M16-L43-Z02-H	●	32	2	29	M16	43	17	14			

R: Sağ/Right L: Sol/Left ● Stokta/In Stock ○ Stokta Yok/Non Stock Item
SMTM Ucuna Uygundur. / Compatible with SMTM Insert.

Sipariş Örneği/Ordering Example : 1 ad./pcs. AEM90-AD1505D-D25-M12-L43-Z02-H
Kesme Hesabı : S 229 / Cutting Calculation : P 229

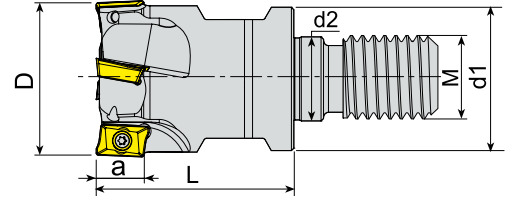



Takım Kodu Ordering Code	Stok Stock	Takım Ölçüleri (mm) Dimension (mm)							Kesici Uç Insert	Yedek Parçaları Spare Parts	
		D	Z	d1	M	L	d2	a		Sıkma Vidası Screw	Tork Anahtar Torx Key
AEM90-AP10-D16-M08-L30-Z02-H	●	16	2	14.75	M08	30	8.5	10	AP.. 1003.. ISO UCUNA UYGUNDUR. FOR ISO INSERT.	3008-M2.5x6	80-T08
AEM90-AP10-D20-M10-L30-Z03-H	●	20	3	18	M10	30	10.5	10			
AEM90-AP10-D25-M12-L35-Z03-H	●	25	3	21	M12	35	12.5	10			
AEM90-AP10-D32-M16-L35-Z04-H	●	32	4	29	M16	35	17	10			
AEM90-AP10-D40-M16-L43-Z05-H	●	40	5	29	M16	43	17	10			
AEM90-AP10-D42-M16-L43-Z05-H	●	42	5	29	M16	43	17	10			
AEM90-AP10D-D16-M08-L30-Z02-H	●	16	2	14.75	M08	30	8.5	10	AP.. 1003.. DJT UCUNA UYGUNDUR. FOR DJT INSERT.	3008-M2.5x6	80-T08
AEM90-AP10D-D20-M10-L30-Z03-H	●	20	3	18	M10	30	10.5	10			
AEM90-AP10D-D25-M12-L35-Z03-H	●	25	3	21	M12	35	12.5	10			
AEM90-AP11-D16-M08-L30-Z02-H	●	16	2	14.75	M08	30	8.5	11	AP.. 11T3.. KRLY-ZCC UCUNA UYGUNDUR. FOR KRLY-ZCC INSERT.	1515-M4x9	80-T15
AEM90-AP11-D20-M10-L30-Z03-H	●	20	3	18	M10	30	10.5	11			
AEM90-AP11-D25-M12-L35-Z03-H	●	25	3	21	M12	35	12.5	11			
AEM90-AP11-D32-M16-L35-Z04-H	●	32	4	29	M16	35	17	11			
AEM90-AP16-D25-M12-L43-Z02-H	●	25	2	21	M12	43	12.5	16	AP.. 1604.. ISO UCUNA UYGUNDUR. FOR ISO INSERT.	1515-M4x9	80-T15
AEM90-AP16-D32-M16-L43-Z03-H	●	32	3	29	M16	43	17	16			
AEM90-AP16-D40-M16-L43-Z04-H	●	40	4	29	M16	43	17	16	AP.. 1604.. DJT UCUNA UYGUNDUR. FOR DJT INSERT.	1515-M4x9	80-T15
AEM90-AP16D-D25-M12-L43-Z02-H	●	25	2	21	M12	43	12.5	16			
AEM90-AP16D-D32-M16-L43-Z03-H	●	32	3	29	M16	43	17	16			
AEM90-AP16D-D40-M16-L43-Z04-H	●	40	4	29	M16	43	17	16	AP.. 1604.. LMN UCUNA UYGUNDUR. FOR LMN INSERT.	1515-M4x9	80-T15
AEM90-AP16L-D25-M12-L43-Z02-H	●	25	2	21	M12	43	12.5	16			
AEM90-AP16L-D32-M16-L43-Z03-H	●	32	3	29	M16	43	17	16			
AEM90-AP16L-D40-M16-L43-Z04-H	●	40	4	29	M16	43	17	16			

R: Sağ/Right L: Sol/Left ● Stokta/In Stock ○ Stokta Yok/Non Stock Item

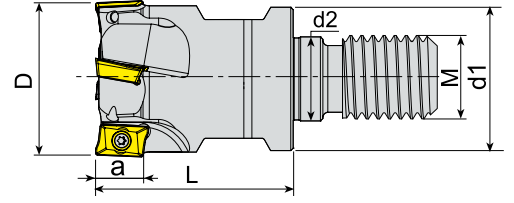

Sipariş Örneği/Ordering Example : 1 ad./pcs. AEM90-AP10-D16-M08-L30-Z02-H
Kesme Hesabı : S 229 / Cutting Calculation : P 229

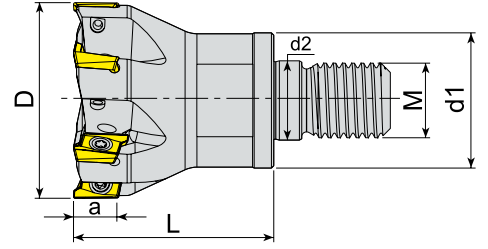

Takım Kodu Ordering Code	Stok Stock	Takım Ölçüleri (mm) Dimension (mm)							Kesici Uç Insert	Yedek Parçaları Spare Parts	
		D	Z	d1	M	L	d2	a		Sıkma Vidası Screw	Tork Anahtar Torx Key
AEM90-R390.11-D16-M08-L30-Z02-H	●	16	2	14.75	M08	30	8.5	10			
AEM90-R390.11-D20-M10-L30-Z03-H	●	20	3	18	M10	30	10.5	10			
AEM90-R390.11-D25-M12-L35-Z03-H	●	25	3	21	M12	35	12.5	10			
AEM90-R390.11-D32-M16-L43-Z04-H	●	32	4	29	M16	43	17	10			

SNDVK Ucuna Uygunur. / Compatiple with SNDVK Insert.

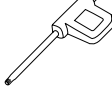

Takım Kodu Ordering Code	Stok Stock	Takım Ölçüleri (mm) Dimension (mm)							Kesici Uç Insert	Yedek Parçaları Spare Parts	
		D	Z	d1	M	L	d2	a		Sıkma Vidası Screw	Tork Anahtar Torx Key
AEM90-RT10-D16-M08-L20-Z02-H	●	16	2	14.75	M08	20	8.5	10			
AEM90-RT10-D20-M10-L25-Z03-H	●	20	3	18	M10	25	10.5	10			
AEM90-RT10-D25-M12-L30-Z04-H	●	25	4	21	M12	30	12.5	10			
AEM90-RT10-D32-M16-L43-Z05-H		32	5	29	M16	43	17	10			
AEM90-RT10-D42-M16-L43-Z06-H		42	6	29	M16	43	17	10			

R: Sağ/Right L: Sol/Left ● Stokta/In Stock ○ Stokta Yok/Non Stock Item
SFTY Ucuna Uygunur. / Compatiple with SFTY Insert.

Sipariş Örneği/Ordering Example : 1 ad./pcs. AEM90-R390.11-D16-M08-L30-Z02-H
Kesme Hesabı : S 229 / Cutting Calculation : P 229

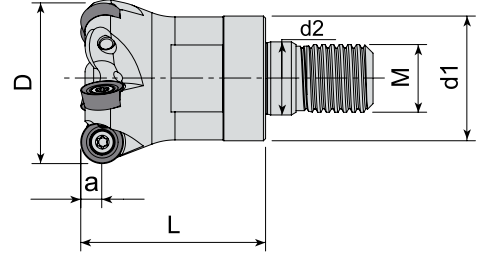

Takım Kodu Ordering Code	Stok Stock	Takım Ölçüleri (mm) Dimension (mm)							Kesici Uç Insert	Yedek Parçaları Spare Parts	
		D	Z	d1	M	L	d2	a		Sıkma Vidası Screw	Tork Anahtar Torx Key
AEMR-RC10T3-D25-M12-L35-Z03-H	●	25	3	21	M12	35	12.5	5	RC.. 10T3..	1515-M4x9	80-T15
AEMR-RC10T3-D32-M16-L43-Z04-H	●	32	4	29	M16	43	17	5			
AEMR-RC10T3-D40-M16-L43-Z05-H	●	40	5	29	M16	43	17	5			

ZCC Ucuna Uygun. / Compatible with ZCC Insert.

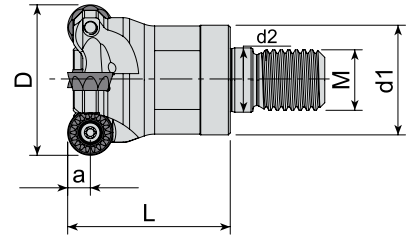

Takım Kodu Ordering Code	Stok Stock	Takım Ölçüleri (mm) Dimension (mm)							Kesici Uç Insert	Yedek Parçaları Spare Parts	
		D	Z	d1	M	L	d2	a		Sıkma Vidası Screw	Tork Anahtar Torx Key
AEMR-RP08T2M-D20-M10-L30-Z02-H	●	20	2	18	M10	30	10.5	4	RPMT 08T2..	3008-M2.5x6	80-T08
AEMR-RP10T3M-D25-M12-L35-Z02-H	●	25	2	21	M12	35	12.5	5	RPMT 10T3..	4015-M3.5x9	80-T15
AEMR-RP1204M-D32-M16-L43-Z03-H	●	32	3	29	M16	43	17	6	RPMT 1204..	1515-M4x9	
AEMR-RP1204M-D40-M16-L43-Z04-H	●	40	4	29	M16	43	17	6			

R: Sağ/Right L: Sol/Left ● Stokta/In Stock ○ Stokta Yok/Non Stock Item
MTSBH Ucuna Uygun. / Compatible with MTSBH Insert.

Sipariş Örneği/Ordering Example : 1 ad./pcs. AEMR-RC10T3-D25-M12-L35-Z03-H
Kesme Hesabı : S 229 / Cutting Calculation : P 229

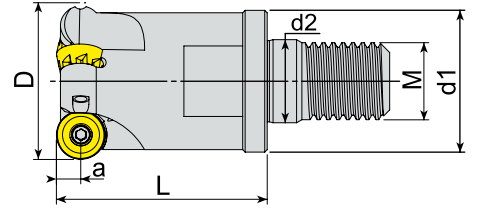

Takım Kodu Ordering Code	Stok Stock	Takım Ölçüleri (mm) Dimension (mm)							Kesici Uç Insert	Yedek Parçaları Spare Parts	
		D	Z	d1	M	L	d2	a		Sıkma Vidası Screw	Tork Anahtar Torx Key
AEMR-RP10T3-D25-M12-L35-Z02-H	●	25	2	21	12	35	12.5	5			
AEMR-RP10T3-D32-M16-L43-Z03-H	●	32	3	29	16	43	17	5			

CRTZT Ucuna Uygundur. / Compatible with CRTZT Insert.

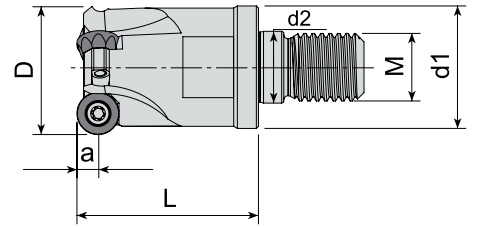

Takım Kodu Ordering Code	Stok Stock	Takım Ölçüleri (mm) Dimension (mm)							Kesici Uç Insert	Yedek Parçaları Spare Parts	
		D	Z	d1	M	L	d2	a		Sıkma Vidası Screw	Tork Anahtar Torx Key
AEMR-QP10T3-D25-M12-L35-Z02-H	●	25	2	21	M12	35	12.5	5			
AEMR-QP10T3-D32-M16-L43-Z03-H	●	32	3	29	M16	43	17	5			

R: Sağ/Right L: Sol/Left ● Stokta/In Stock ○ Stokta Yok/Non Stock Item
SMTM Ucuna Uygundur. / Compatible with SMTM Insert.

Sipariş Örneği/Ordering Example : 1 ad./pcs. AEMR-RP10T3-D25-M12-L35-Z02-H
Kesme Hesabı : S 229 / Cutting Calculation : P 229

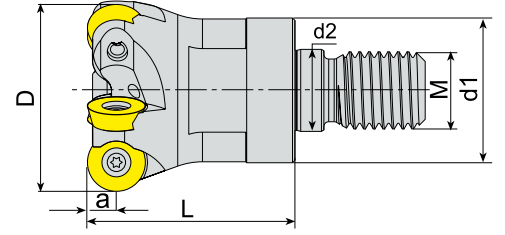

Takım Kodu Ordering Code	Stok Stock	Takım Ölçüleri (mm) Dimension (mm)							Kesici Uç Insert	Yedek Parçaları Spare Parts	
		D	Z	d1	M	L	d2	a		Sıkma Vidası Screw	Tork Anahtar Torx Key
AEMR-RD0702-D15-M08-L23-Z02-H	●	15	2	13	M08	23	8.5	3.5	RD.. 0702	3008-M2.5x6	80-T08
AEMR-RD0702-D16-M08-L23-Z02-H	●	16	2	13	M08	23	8.5	3.5			
AEMR-RD0702-D20-M10-L30-Z04-H	●	20	4	18	M10	30	10.5	3.5			
AEMR-RD0702-D25-M12-L35-Z05-H	●	25	5	21	M12	35	12.5	3.5			
AEMR-RD0702-D30-M16-L42-Z05-H	●	30	5	29	M16	42	17	3.5			
AEMR-RD0702-D32-M16-L43-Z05-H	●	32	5	29	M16	43	17	3.5			
AEMR-RD0702-D35-M16-L42-Z06-H	●	35	6	29	M16	42	17	3.5			
AEMR-RD0702-D42-M16-L43-Z05-H	●	42	5	29	M16	43	17	3.5			
AEMR-RD0702-D42-M16-L43-Z07-H	●	42	7	29	M16	43	17	3.5			
AEMR-RD08T2-D16-M08-L23-Z02-H	●	16	2	13	M08	23	8.5	4	RD.. 08T2	3008-M2.5x6	80-T08
AEMR-RD08T2-D20-M10-L30-Z03-H	●	20	3	18	M10	30	10.5	4			
AEMR-RD08T2-D25-M12-L35-Z04-H	●	25	4	21	M12	35	12.5	4			
AEMR-RD0803-D16-M08-L23-Z02-H	●	16	2	13	M08	23	8.5	4	RD.. 0803	1008-M3x6	80-T15
AEMR-RD0803-D20-M10-L30-Z03-H	●	20	3	18	M10	30	10.5	4		1008-M3x8	
AEMR-RD0803-D25-M12-L35-Z04-H	●	25	4	21	M12	35	12.5	4			
AEMR-RD1003-D20-M10-L30-Z02-H	●	20	2	18	M10	30	10.5	5	RD.. 1003	4015-M3.5x9	80-T15
AEMR-RD1003-D25-M12-L35-Z02-H	●	25	2	21	M12	35	12.5	5			
AEMR-RD1003-D25-M12-L35-Z03-H	●	25	3	21	M12	35	12.5	5			
AEMR-RD1003-D30-M16-L43-Z04-H	●	30	4	29	M16	43	17	5			
AEMR-RD1003-D32-M16-L43-Z04-H	●	32	4	29	M16	43	17	5			
AEMR-RD1003-D35-M16-L43-Z04-H	●	35	4	29	M16	43	17	5			
AEMR-RD1003-D40-M16-L43-Z05-H	●	40	5	29	M16	43	17	5			
AEMR-RD1003-D42-M16-L43-Z05-H	●	42	5	29	M16	43	17	5			
AEMR-RD12T3-D24-M12-L35-Z02-H	●	24	2	21	M12	35	12.5	6	RD.. 12T3	4015-M3.5x9	80-T15
AEMR-RD12T3-D25-M12-L35-Z02-H	●	25	2	21	M12	35	12.5	6			
AEMR-RD12T3-D32-M16-L43-Z03-H	●	32	3	29	M16	43	17	6			
AEMR-RD12T3-D35-M16-L43-Z03-H	●	35	3	29	M16	43	17	6			
AEMR-RD12T3-D35-M16-L43-Z04-H	●	35	4	29	M16	43	17	6			
AEMR-RD12T3-D40-M16-L43-Z04-H	●	40	4	29	M16	43	17	6			
AEMR-RD12T3-D42-M16-L43-Z05-H	●	42	5	29	M16	43	17	6			
AEMR-RD1204-D32-M16-L43-Z03-H	●	32	3	29	M16	43	17	6	RD.. 1204	4015-M3.5x9	80-T15
AEMR-RD1204-D42-M16-L43-Z04-H	●	42	4	29	M16	43	17	6			
AEMR-RD1604-D32-M16-L43-Z02-H	●	32	2	29	M16	43	17	8	RD.. 1604	1515-M4.5X11	80-T15
AEMR-RD1604-D40-M16-L43-Z02-H	●	40	2	29	M16	43	17	8			
AEMR-RD1604-D42-M16-L43-Z03-H	●	42	3	29	M16	43	17	8			

R: Sağ/Right L: Sol/Left ● Stokta/In Stock ○ Stokta Yok/Non Stock Item
ISO Ucuna Uygundur. / Compatible with ISO Insert.

Sipariş Örneği/Ordering Example : 1 ad./pcs. AEMR-RD0702-D15-M08-L23-Z02-H
Kesme Hesabı : S 229 / Cutting Calculation : P 229

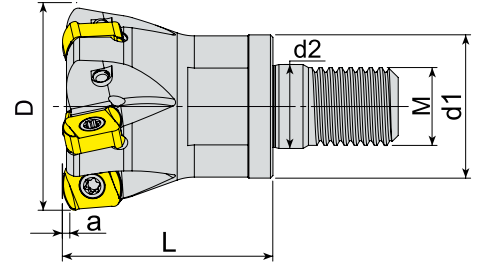

Takım Kodu Ordering Code	Stok Stock	Takım Ölçüleri (mm) Dimension (mm)							Kesici Uç Insert	Yedek Parçaları Spare Parts	
		D	Z	d1	M	L	d2	a		Sıkma Vidası Screw	Tork Anahtar Torx Key
AHFM-BL0603-D32-M16-L40-Z05-H	●	32	5	21	M16	40	17	1			80-T08
AHFM-BL0904-D42-M16-L43-Z05-H	●	42	5	29	M16	43	17	2			80-T10

TGTC Ucuna Uygunudur. / Compatiple with TGTC Insert.

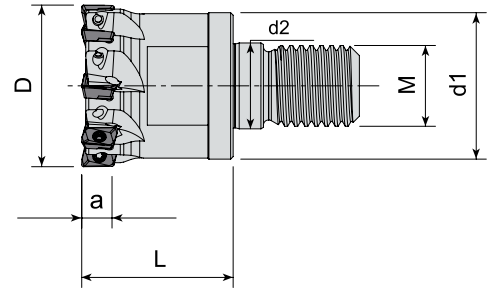

Takım Kodu Ordering Code	Stok Stock	Takım Ölçüleri (mm) Dimension (mm)							Kesici Uç Insert	Yedek Parçaları Spare Parts	
		D	Z	d1	M	L	d2	a		Sıkma Vidası Screw	Tork Anahtar Torx Key
AHFM-ED0702-D12-M06-L20-Z03	●	12	3	10	M06	20	6.5	6			80-T06
AHFM-ED0702-D16-M08-L25-Z04-H	●	16	4	14.75	M08	25	8.5	6			
AHFM-ED0702-D20-M10-L30-Z05-H	●	20	5	18	M10	30	10.5	6			
AHFM-ED0702-D25-M12-L30-Z06-H	●	25	6	21	M12	30	12.5	6			
AHFM-ED0702-D32-M16-L30-Z08-H	●	32	8	29	M16	30	17	6			

R: Sağ/Right L: Sol/Left ● Stokta/In Stock ○ Stokta Yok/Non Stock Item
HTCH Ucuna Uygunudur. / Compatiple with HTCH Insert.

Sipariş Örneği/Ordering Example : 1 ad./pcs. AHFM-BL0603-D32-M16-L40-Z05-H
Kesme Hesabı : S 229 / Cutting Calculation : P 229

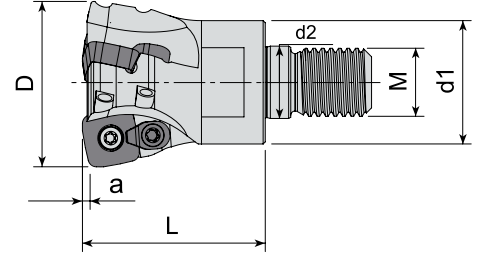

Takım Kodu Ordering Code	Stok Stock	Takım Ölçüleri (mm) Dimension (mm)							Kesici Uç Insert	Yedek Parçaları Spare Parts			
		D	Z	d1	M	L	d2	a		Sıkma Vidası Screw	Baskı Parçası Wedge Clamp	Baskı Vidası Clamp Screw	Tork Anahtar Torx Key
AHFMC-SD09T3-D22-M12-L30-Z02-H	○	22	2	22	M12	30	12.5	1.4	SD.. 09T3..				
AHFMC-SD09T3-D25-M12-L30-Z02-H	●	25	2	22	M12	30	12.5	1.4					
AHFMC-SD09T3-D32-M16-L43-Z03-H	●	32	3	29	M16	43	17	1.4					
AHFMC-SD09T3-D35-M16-L43-Z03-H	●	35	3	29	M16	43	17	1.4					
AHFMC-SD09T3-D40-M16-L43-Z04-H	●	40	4	29	M16	43	17	1.4					
AHFMC-SD1204-D32-M16-L43-Z02-H	●	32	2	29	M16	43	17	1.8	SD.. 1204..				
AHFMC-SD1204-D40-M16-L43-Z03-H	●	40	3	29	M16	43	17	1.8					

ZCC Ucuna Uygunudur. / Compatible with ZCC Insert.

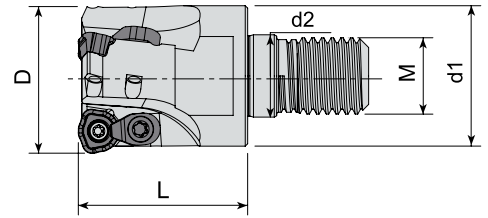

Takım Kodu Ordering Code	Stok Stock	Takım Ölçüleri (mm) Dimension (mm)							Kesici Uç Insert	Yedek Parçaları Spare Parts			
		D	Z	d1	M	L	d2	a		Sıkma Vidası Screw	Baskı Parçası Wedge Clamp	Baskı Vidası Clamp Screw	Tork Anahtar Torx Key
AHFMC-WD0804-D25-M12-L35-Z02-H	●	25	2	21	M12	35	12.5	-	WDMT 0804..				
AHFMC-WD0804-D32-M16-L35-Z03-H	●	32	3	29	M16	35	17	-					

R: Sağ/Right L: Sol/Left ● Stokta/In Stock ○ Stokta Yok/Non Stock Item
SMTM Ucuna Uygunudur. / Compatible with SMTM Insert.

Sipariş Örneği/Ordering Example : 1 ad./pcs. AHFMC-SD09T3-D22-M12-L30-Z02-H
Kesme Hesabı : S 229 / Cutting Calculation : P 229

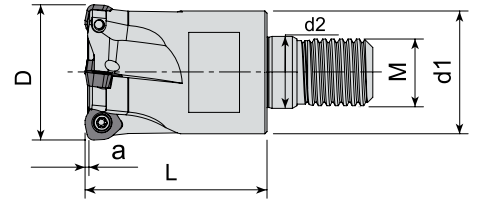

Takım Kodu Ordering Code	Stok Stock	Takım Ölçüleri (mm) Dimension (mm)							Kesici Uç Insert	Yedek Parçaları Spare Parts			
		D	Z	d1	M	L	d2	a		Sıkma Vidası Screw	Baskı Parçası Wedge Clamp	Baskı Vidası Clamp Screw	Tork Anahtar Torx Key
AHFM-WD0503D-D20-M10-L30-Z02-H	●	20	2	18	M10	30	10.5	-	WDMT 0503..	4010-M3x6			80-T10
AHFM-WD0503D-D25-M12-L35-Z03-H	●	25	3	21	M12	35	12.5	-		4010-M3x8	-	-	
AHFM-WD0503D-D32-M16-L43-Z04-H	●	32	4	29	M16	43	17	-					
AHFM-WD0503D-D40-M16-L43-Z05-H	●	40	5	29	M16	43	17	-					
AHFMC-WD06T3D-D35-M16-L43-Z03-H	●	35	3	29	M16	43	17	1.5	WDHW 06T3..	3015-M3.5x9	ACK-15	1015-M3.5x11	80-T15

DJT Ucuna Uygunudur. / Compatible with DJT Insert.

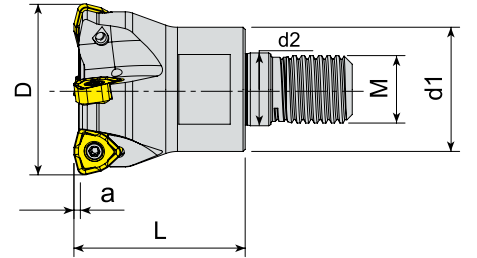



Takım Kodu Ordering Code	Stok Stock	Takım Ölçüleri (mm) Dimension (mm)							Kesici Uç Insert	Yedek Parçaları Spare Parts	
		D	Z	d1	M	L	d2	a		Sıkma Vidası Screw	Tork Anahtar Torx Key
AHFM-WN09T3-D32-M16-L40-Z03-H	●	32	3	29	M16	40	17	1.5	WNMX 09T3..	4010-M3x8	80-T10
AHFM-WN09T3-D40-M16-L40-Z04-H	●	40	4	29	M16	40	17	1.5			

R: Sağ/Right L: Sol/Left ● Stokta/In Stock ○ Stokta Yok/Non Stock Item
KRLY Ucuna Uygunudur. / Compatible with KRLY Insert.

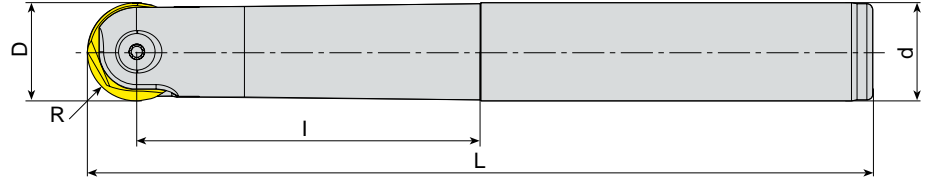

Sipariş Örneği/Ordering Example : 1 ad./pcs. AHFM-WD0503D-D20-M10-L30-Z02-H
Kesme Hesabı : S 229 / Cutting Calculation : P 229

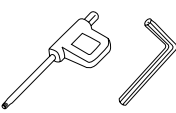

Takım Kodu Ordering Code	Stok Stock	Takım Ölçüleri (mm) Dimension (mm)					Kesici Uç Insert	Yedek Parçaları Spare Parts	
		D	R	d	L	l		Sıkma Vidası Screw	Anahtar Key
APMR-P3208-D08-C10-L110	●	8	4	10	110	25			
APMR-P3210-D10-C10-L130	●	10	5	10	130	30	P3210	1215-M4x0.5x9	80-T15
APMR-P3210-D10-C12-L130	●	10	5	12	130	30			
APMR-P3212-D12-C12-L130	●	12	6	12	130	32	P3212	1220-M5x0.5x9	80-T20
APMR-P3216-D16-C16-L175	●	16	8	16	175	60	P3216	1220-M5x0.5x12	
APMR-P3220-D20-C20-L200	●	20	10	20	200	100	P3220	1220-M5x0.5x15	
APMR-P3225-D25-C25-L200	●	25	12.5	25	200	100	P3225	1220-M6x0.75x20	AAL-05-4
APMR-P3232-D32-C32-L200	●	32	16	32	200	100	P3232	1204-M8x0.75x26	

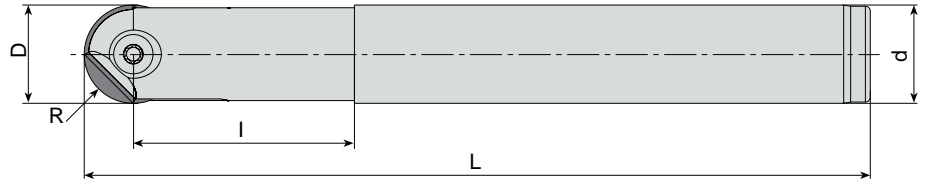
WLTR Ucuna Uygunur. / Compatible with WLTR Insert.



Takım Kodu Ordering Code	Stok Stock	Takım Ölçüleri (mm) Dimension (mm)					Kesici Uç Insert	Yedek Parçaları Spare Parts	
		D	R	d	L	l		Sıkma Vidası Screw	Tork Anahtar Torx Key
APMR-R012-D12-C12-L120	●	12	6	12	120	35	ROHX 1203		
APMR-R012-D12-C16-L160	●	12	6	16	160	50			
APMR-R016-D16-C16-L160	●	16	8	16	160	45	ROHX 1604	1220-M5x0.5x12	80-T20
APMR-R016-D16-C16-L200	●	16	8	16	200	45			
APMR-R016-D16-C20-L200	●	16	8	20	200	65	ROHX 2005	1220-M5x0.5x15	
APMR-R020-D20-C20-L160	●	20	10	20	160	55			
APMR-R020-D20-C20-L200	●	20	10	20	200	55			
APMR-R020-D20-C25-L220	●	20	10	25	220	80			

R: Sağ/Right L: Sol/Left ● Stokta/In Stock ○ Stokta Yok/Non Stock Item
ZCC Ucuna Uygunur. / Compatible with ZCC Insert.

Sipariş Örneği/Ordering Example : 1 ad./pcs. APMR-P3208-D08-C10-L110
Kesme Hesabı : S 229 / Cutting Calculation : P 229

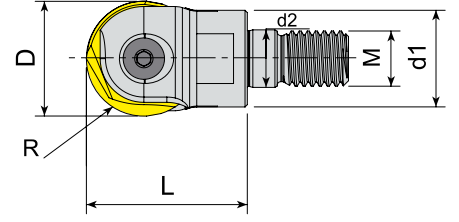

Takım Kodu Ordering Code	Stok Stock	Takım Ölçüleri (mm) Dimension (mm)						Kesici Uç Insert	Yedek Parçaları Spare Parts	
		D	R	d1	M	L	d2		Sıkma Vidası Screw	Tork Anahtar Torx Key
APMR-P3216-D16-M08-L25	●	16	8	14	M08	25	8.5		1220-M5x0.5x12	80-T20
APMR-P3220-D20-M10-L30	●	20	10	18	M10	30	10.5		1220-M5x0.5x15	
APMR-P3225-D25-M12-L35	●	25	12.5	21	M12	35	12.5		1220-M6x0.75x20	AAL-05-4
APMR-P3232-D32-M16-L43	●	32	16	30	M16	43	17		1204-M8x0.75x26	

WLTR Ucuna Uygunudur. / Compatible with WLTR Insert.

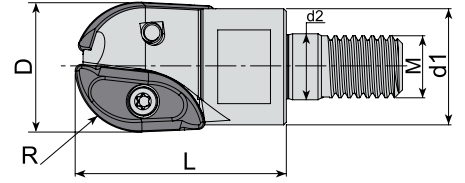

Takım Kodu Ordering Code	Stok Stock	Takım Ölçüleri (mm) Dimension (mm)						Kesici Uç Insert	Yedek Parçaları Spare Parts	
		D	R	d1	M	L	d2		Sıkma Vidası Screw	Tork Anahtar Torx Key
APMR-SWB225-D25-M12-L35	●	25	12.5	23.5	M12	35	12.5		1020-M5x11	80-T20
APMR-SWB232-D32-M16-L43	●	32	16	30	M16	43	17			

R: Sağ/Right L: Sol/Left ● Stokta/In Stock ○ Stokta Yok/Non Stock Item
DJT Ucuna Uygunudur. / Compatible with DJT Insert.

Sipariş Örneği/Ordering Example : 1 ad./pcs. APMR-P3216-D16-M08-L25
Kesme Hesabı : S 229 / Cutting Calculation : P 229

➤ KÜRE UÇLU MODÜLER PARMAK FREZELER
BALL NOSE MODULAR (SCREW TYPE) END MILLS

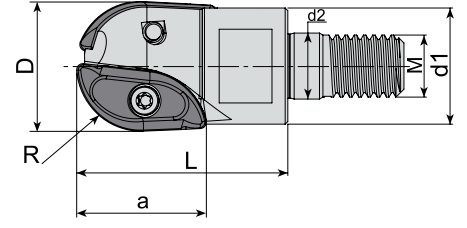

Takım Kodu Ordering Code	Stok Stock	Takım Ölçüleri (mm) Dimension (mm)							Kesici Uç Insert	Yedek Parçaları Spare Parts	
		D	R	d1	M	L	a	d2		Sıkma Vidası Screw	Tork Anahtar Torx Key
APMR-XP16-D16-M08-L25	●	16	8	14.75	M08	25	16	8.5		3008-M2.5x6	80-T08
APMR-XP20-D20-M10-L30	●	20	10	18	M10	30	20	10.5		1510-M3.5x9	80-T10
APMR-XP25-D25-M12-L35	●	25	12.5	22	M12	40	25	12.5		1515-M4x9	80-T15

ZCC Ucuna Uygunur. / Compatiple with ZCC Insert.

➤ VİDALI TAKIM TUTUCULARI
SCREWED TOOL HOLDERS

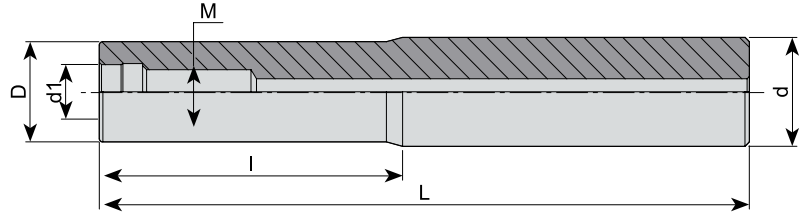







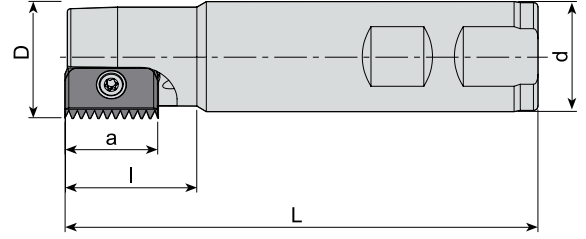

Takım Kodu Ordering Code	Stok Stock	Takım Ölçüleri (mm) Dimension (mm)					
		d	M	d1	D	L	l
AVTT-D13-C16-M08-L100-H	●	16	M08	8.5	13	100	40
AVTT-D15-C16-M08-L130-H	●	16	M08	8.5	15	130	70
AVTT-D18-C20-M10-L130-H	●	20	M10	10.5	18	130	70
AVTT-D18-C20-M10-L160-H	●	20	M10	10.5	18	160	80
AVTT-D23-C25-M12-L150-H	●	25	M12	12.5	23	150	70
AVTT-D23-C25-M12-L200-H	●	25	M12	12.5	23	200	100
AVTT-D23-C25-M12-L250-H	●	25	M12	12.5	23	250	150
AVTT-D30-C32-M16-L150-H	●	32	M16	17	30	150	70
AVTT-D30-C32-M16-L200-H	●	32	M16	17	30	200	100
AVTT-D30-C32-M16-L250-H	●	32	M16	17	30	250	150
AVTT-D30-C32-M16-L300-H	●	32	M16	17	30	300	200

R: Sağ/Right L: Sol/Left ● Stokta/In Stock ○ Stokta Yok/Non Stock Item

Sipariş Örneği/Ordering Example : 1 ad./pcs. APMR-XP16-N16-M08-L25

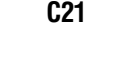

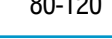

Kesme Hesabı : S 229 / Cutting Calculation : P 229

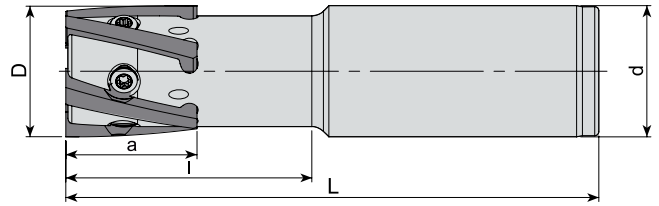

Takım Kodu Ordering Code	Stok Stock	Takım Ölçüleri (mm) Dimension (mm)						Kesici Uç Insert	Yedek Parçaları Spare Parts	
		D	Z	d	L	l	a		Sıkma Vidası Screw	Tork Anahtar Torx Key
ATM-C14-D14-W20-L100-Z01-H	●	14	1	20	100	25	14			
ATM-C21-D18-W20-L100-Z01-H	●	18	1	20	100	30	21			
ATM-C21-D25-W20-L125-Z01-H	●	25	1	20	125	30	21			
ATM-C21-D28-W25-L90-Z01-H	●	28	1	25	90	30	21			
ATM-C21-D38-W32-L120-Z03-H	●	38	3	32	120	30	21			
ATM-C21-D43-W32-L90-Z03-H	●	43	3	32	90	30	21			
ATM-C30-D29-W25-L150-Z01-H	●	29	1	25	150	50	30			

CPT Ucuna Uygun. / Compatible with CPT Insert.

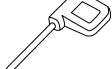

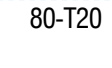

Takım Kodu Ordering Code	Stok Stock	Takım Ölçüleri (mm) Dimension (mm)						Kesici Uç Insert	Yedek Parçaları Spare Parts	
		D	Z	d	L	l	a		Sıkma Vidası Screw	Tork Anahtar Torx Key
ATM-H23-D23-C25-L100-Z02-H	●	23	2	25	100	30	27			
ATM-H32-D32-C32-L130-Z05-H	●	32	5	32	130	35	32			

R: Sağ/Right L: Sol/Left ● Stokta/In Stock ○ Stokta Yok/Non Stock Item
CPT Ucuna Uygun. / Compatible with CPT Insert.

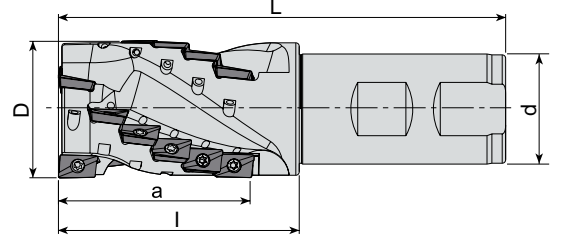
Sipariş Örneği/Ordering Example : 1 ad./pcs. ATM-C14-D14-W20-L100-Z01-H
Kesme Hesabı : S 229 / Cutting Calculation : P 229

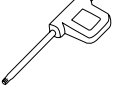

Takım Kodu Ordering Code	Stok Stock	Takım Ölçüleri (mm) Dimension (mm)							Kesici Uç Insert	Yedek Parçaları Spare Parts	
		Z		D	d	a	l	L		Sıkma Vidası Screw	Tork Anahtar Torx Key
		Toplam Total	Etkili Effective								
AHM90-AP10-D20-W20-L087-Z04	●	4	2	20	20	28	37	87			
AHM90-AP10-D20-W20-L087-Z0206-H	●	6	2	20	20	28	37	87			
AHM90-AP10-D25-W25-L105-Z0208-H	●	8	2	25	25	37	47	105			
AHM90-AP10-D32-W32-L115-Z0315-H	●	15	3	32	32	46	55	115			
AHM90-AP10-D40-W32-L130-Z0318-H	●	18	3	40	32	55	64	130			

R: Sağ/Right L: Sol/Left ● Stokta/In Stock ○ Stokta Yok/Non Stock Item
ISO Ucuna Uygundur. / Compatible with ISO Insert.

Sipariş Örneği/Ordering Example : 1 ad./pcs. AHM90-AP10-D20-W20-L087-Z04
Kesme Hesabı : S 229 / Cutting Calculation : P 229



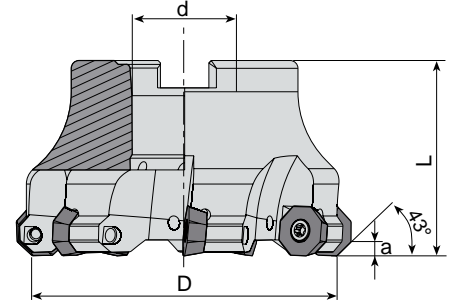

Takım Kodu Ordering Code	Stok Stock	Takım Ölçüleri (mm) Dimension (mm)					Kesici Uç Insert	Yedek Parçaları Spare Parts		
		D	Z	d	L	a		Sıkma Vidası Screw	Tork Anahtar Torx Key	Montaj Vidası Mounting Screw
AFM43-OD0504-D040-A16-Z04-H	●	40	4	16	40	3.5	OD.. 0504..			2506-M8x30
AFM43-OD0504-D050-A22-Z05-H	●	50	5	22	40	3.5				2407-M10x30
AFM43-OD0504-D063-A22-Z06-H	●	63	6	22	40	3.5				2510-M12x35
AFM43-OD0504-D080-A27-Z07-H	●	80	7	27	50	3.5				2514-M16x35
AFM43-OD0504-D100-A32-Z08-H	●	100	8	32	50	3.5				

WLTR Ucuna Uygunur. / Compatiple with WLTR Insert.

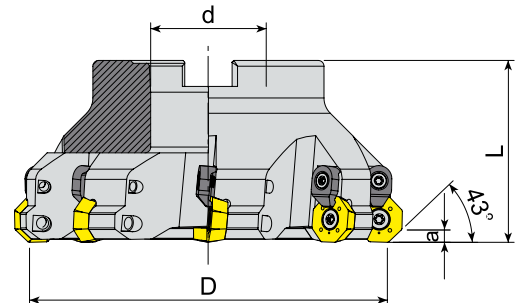

Takım Kodu Ordering Code	Stok Stock	Takım Ölçüleri (mm) Dimension (mm)					Kesici Uç Insert	Yedek Parçaları Spare Parts								
		D	Z	d	L	a		Sıkma Vidası Screw	Baskı Parçası Wedge Clamp	Baskı Vidası Clamp Screw	Tork Anahtar Torx Key	Montaj Vidası Mounting Screw				
AFM43C-OD0605-D080-A27-Z06-H	●	80	6	27	50	4	OD.. 0605..					2510-M12x35				
AFM43C-OD0605-D100-A32-Z07-H	●	100	7	32	50	4						1020-M5x11	ACK-05	1515-M4x11	80-T20	2514-M16x35
AFM43C-OD0605-D125-B40-Z08	●	125	8	40	63	4										-

R: Sağ/Right L: Sol/Left ● Stokta/In Stock ○ Stokta Yok/Non Stock Item
WLTR-LMN Ucuna Uygunur. / Compatiple with WLTR-LMN Insert.

Sipariş Örneği/Ordering Example : 1 ad./pcs. AFM43-OD0504-D040-A16-Z04-H
Kesme Hesabı : S 229 / Cutting Calculation : P 229
Montaj Ölçüleri : S 227 / Mounting Reference : P 227

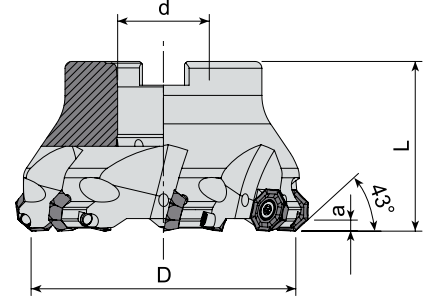

Takım Kodu Ordering Code	Stok Stock	Takım Ölçüleri (mm) Dimension (mm)					Kesici Uç Insert	Yedek Parçaları Spare Parts		
		D	Z	d	L	a		Sıkma Vidası Screw	Tork Anahtar Torx Key	Montaj Vidası Mounting Screw
AFM43-OF05T3-D050-A22-Z05-H	●	50	5	22	40	3	OF.. 05T3..	1515-M4x9	80-T15	2407-M10x30
AFM43-OF05T3-D063-A22-Z06-H	●	63	6	22	40	3				2510-M12x35
AFM43-OF05T3-D080-A27-Z07-H	●	80	7	27	50	3				-
AFM43-OF05T3-D125-B40-Z09	●	125	9	40	63	3				-

ISO Ucuna Uygundur. / Compatible with ISO Insert.

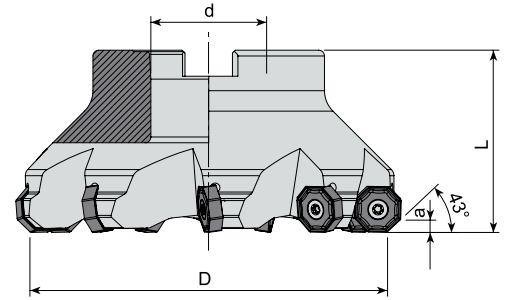

Takım Kodu Ordering Code	Stok Stock	Takım Ölçüleri (mm) Dimension (mm)					Kesici Uç Insert	Yedek Parçaları Spare Parts		
		D	Z	d	L	a		Sıkma Vidası Screw	Tork Anahtar Torx Key	Montaj Vidası Mounting Screw
AFM43-ON0604-D050-A22-Z05-H	●	50	5	22	40	4	ON.. 0604..	1515-M4x11	80-T15	2508-M10x30
AFM43-ON0604-D063-A22-Z06-H	●	63	6	22	40	4				2510-M12x35
AFM43-ON0604-D080-A27-Z07-H	●	80	7	27	50	4				2514-M16x35
AFM43-ON0604-D100-A32-Z08-H	●	100	8	32	50	4				-
AFM43-ON0604-D125-B40-Z09	●	125	9	40	63	4				-

R: Sağ/Right L: Sol/Left ● Stokta/In Stock ○ Stokta Yok/Non Stock Item
ZCC Ucuna Uygundur. / Compatible with ZCC Insert.

Sipariş Örneği/Ordering Example : 1 ad./pcs. AFM43-OF05T3-D050-A22-Z05-H
Kesme Hesabı : S 229 / Cutting Calculation : P 229
Montaj Ölçüleri : S 227 / Mounting Reference : P 227

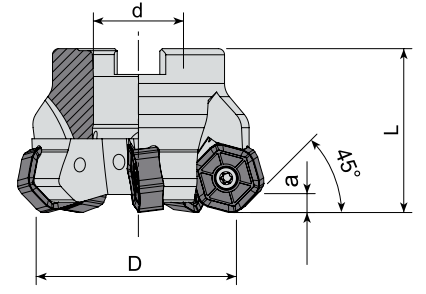

Takım Kodu Ordering Code	Stok Stock	Takım Ölçüleri (mm) Dimension (mm)					Kesici Uç Insert	Yedek Parçaları Spare Parts		
		D	Z	d	L	a		Sıkma Vidası Screw	Tork Anahtar Torx Key	Montaj Vidası Mounting Screw
AFM45-HN0905-D050-A22-Z05-H	●	50	5	22	40	4.5	HN.. 0905..	1515-M4x11	80-T15	2407-M10x30
AFM45-HN0905-D063-A22-Z06-H	●	63	6	22	40	4.5				
AFM45-HN0905-D080-A27-Z07-H	●	80	7	27	50	4.5				

WDA Ucuna Uygundur. / Compatiple with WDA Insert.

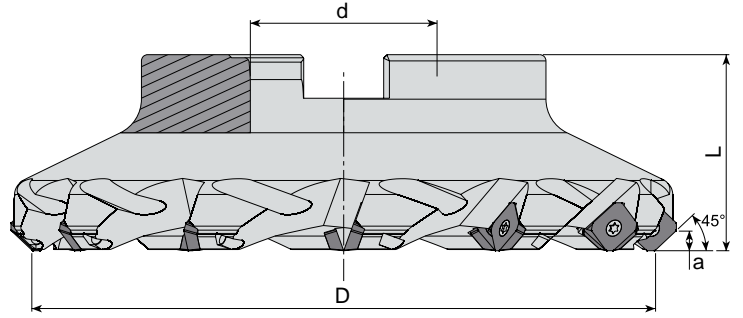

Takım Kodu Ordering Code	Stok Stock	Takım Ölçüleri (mm) Dimension (mm)					Kesici Uç Insert	Yedek Parçaları Spare Parts		
		D	Z	d	L	a		Sıkma Vidası Screw	Tork Anahtar Torx Key	Montaj Vidası Mounting Screw
AFM45-SE12-D050-A22-Z04-H	●	50	4	22	40	6	SE.. 12T3.. R245-12T3..	4015-M3.5x11	80-T15	2407-M10x30
AFM45L-SE12-D050-A22-Z04-H	●	50	4	22	40	6				
AFM45-SE12-D063-A22-Z05-H	●	63	5	22	40	6				2510-M12x35
AFM45L-SE12-D063-A22-Z05-H	●	63	5	22	40	6				
AFM45-SE12-D080-A27-Z06-H	●	80	6	27	50	6				2514-M16x35
AFM45L-SE12-D080-A27-Z06-H	●	80	6	27	50	6				
AFM45-SE12-D100-A32-Z07-H	●	100	7	32	50	6				-
AFM45-SE12-D125-B40-Z08	●	125	8	40	63	6				-
AFM45-SE12-D160-C40-Z10	●	160	10	40	63	6				-
AFM45-SE12-D200-C60-Z12	●	200	12	60	63	6				-

R: Sağ/Right L: Sol/Left ● Stokta/In Stock ○ Stokta Yok/Non Stock Item
ZCC-SNDVK Ucuna Uygundur. / Compatiple with ZCC-SNDVK Insert.

Sipariş Örneği/Ordering Example : 1 ad./pcs. AFM45-HN0905-D050-A22-Z05-H
Kesme Hesabı : S 229 / Cutting Calculation : P 229
Montaj Ölçüleri : S 227 / Mounting Reference : P 227

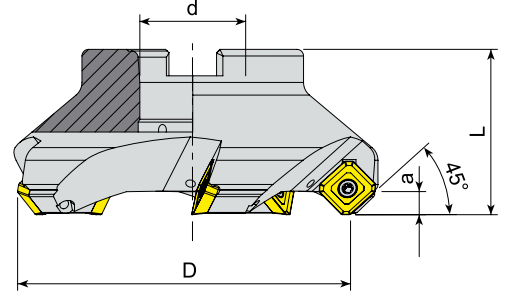

Takım Kodu Ordering Code	Stok Stock	Takım Ölçüleri (mm) Dimension (mm)					Kesici Uç Insert	Yedek Parçaları Spare Parts		
		D	Z	d	L	a		Sıkma Vidası Screw	Tork Anahtar Torx Key	Montaj Vidası Mounting Screw
AFM45-SE14M4-D063-A22-Z04-H	●	63	4	22	40	7	SE.. 14M4..	4015-M3.5x11	80-T15	2407-M10x30
AFM45-SE14M4-D080-A27-Z05-H	●	80	5	27	50	7				2510-M12x35
AFM45-SE14M4-D100-A32-Z05-H	●	100	5	32	50	7				2514-M16x35
AFM45-SE14M4-D125-B40-Z06	●	125	6	40	63	7				-
AFM45-SE14M4-D160-C40-Z07	●	160	7	40	63	7				-

KRLY Ucuna Uygunur. / Compatiple with KRLY Insert.

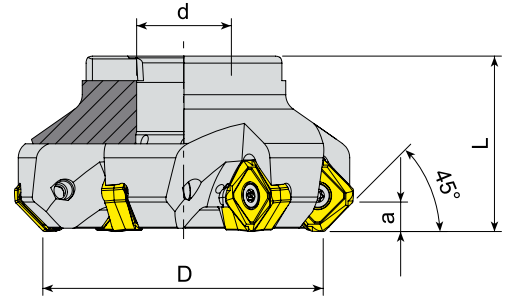

Takım Kodu Ordering Code	Stok Stock	Takım Ölçüleri (mm) Dimension (mm)					Kesici Uç Insert	Yedek Parçaları Spare Parts		
		D	Z	d	L	a		Sıkma Vidası Screw	Tork Anahtar Torx Key	Montaj Vidası Mounting Screw
AFM45-SA1706-D080-A27-Z06-H	●	80	6	27	50	8.4	SAKU 1706..	1020-M5x14	80-T20	2510-M12x35
AFM45-SA1706-D100-A32-Z07-H	●	100	7	32	50	8.4				2514-M16x35
AFM45-SA1706-D125-B40-Z09	●	125	9	40	63	8.4				-

R: Sağ/Right L: Sol/Left ● Stokta/In Stock ○ Stokta Yok/Non Stock Item
CRTZT Ucuna Uygunur. / Compatiple with CRTZT Insert.

Sipariş Örneği/Ordering Example : 1 ad./pcs. AFM45-SE14M4-D063-A22-Z04-H
Kesme Hesabı : S 229 / Cutting Calculation : P 229
Montaj Ölçüleri : S 227 / Mounting Reference : P 227

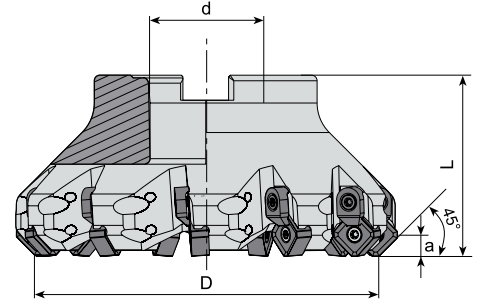

Takım Kodu Ordering Code	Stok Stock	Takım Ölçüleri (mm) Dimension (mm)					Kesici Uç Insert	Yedek Parçaları Spare Parts				
		D	Z	d	L	a		Sıkma Vidası Screw	Baskı Parçası Wedge Clamp	Baskı Vidası Clamp Screw	Tork Anahtar Torx Key	Montaj Vidası Mounting Screw
AFM45C-SN1206-D050-A22-Z05-H	●	50	5	22	42	6	SN.. 1206..	1515-M4x11	ACK-05	1515-M4x11	80-T15	2407-M10x30
AFM45C-SN1206-D063-A22-Z07-H	●	63	7	22	42	6						
AFM45CL-SN1206-D063-A22-Z07-H	●	63	7	22	42	6						
AFM45C-SN1206-D080-A27-Z08-H	●	80	8	27	52	6						
AFM45C-SN1206-D100-A32-Z10-H	●	100	10	32	52	6						
AFM45CL-SN1206-D100-A32-Z10-H	●	100	10	32	52	6						
AFM45C-SN1206-D125-B40-Z11	●	125	11	40	65	6						
AFM45CL-SN1206-D125-B40-Z11	●	125	11	40	65	6						
AFM45C-SN1206-D160-C40-Z12	●	160	12	40	65	6						
AFM45C-SN1206-D200-C60-Z14	●	200	14	60	65	6						
AFM45CL-SN1206-D200-C60-Z14	●	200	14	60	65	6						

ISO Ucuna Uygunur. / Compatiple with ISO Insert.

WLTR ucu ile kullanılacaksa, sipariş verirken belirtilmelidir.
If will be used with WLTR insert, should be mentioned on order.

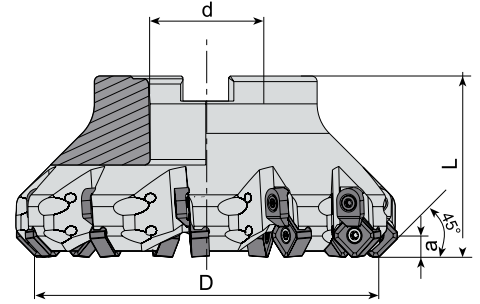

Takım Kodu Ordering Code	Stok Stock	Takım Ölçüleri (mm) Dimension (mm)					Kesici Uç Insert	Yedek Parçaları Spare Parts				
		D	Z	d	L	a		Sıkma Vidası Screw	Baskı Parçası Wedge Clamp	Baskı Vidası Clamp Screw	Tork Anahtar Torx Key	Montaj Vidası Mounting Screw
AFM45C-SN12Z-D050-A22-Z05-H	●	50	5	22	42	6	SNEG 1205..	1515-M4x11	ACK-05	1515-M4x11	80-T15	2407-M10x30
AFM45C-SN12Z-D063-A22-Z06-H	●	63	6	22	42	6						
AFM45C-SN12Z-D080-A27-Z07-H	●	80	7	27	52	6						
AFM45C-SN12Z-D100-A32-Z09-H	●	100	9	32	52	6						
AFM45C-SN12Z-D125-B40-Z11	●	125	11	40	65	6						
AFM45C-SN12Z-D160-C40-Z12	○	160	12	40	65	6						
AFM45C-SN12Z-D200-C60-Z14	●	200	14	60	65	6						

R: Sağ/Right L: Sol/Left ● Stokta/In Stock ○ Stokta Yok/Non Stock Item
ZCC Ucuna Uygunur. / Compatiple with ZCC Insert.

Sipariş Örneği/Ordering Example : 1 ad./pcs. AFM45C-SN1206-D050-A22-Z04-H
Kesme Hesabı : S 229 / Cutting Calculation : P 229
Montaj Ölçüleri : S 227 / Mounting Reference : P 227

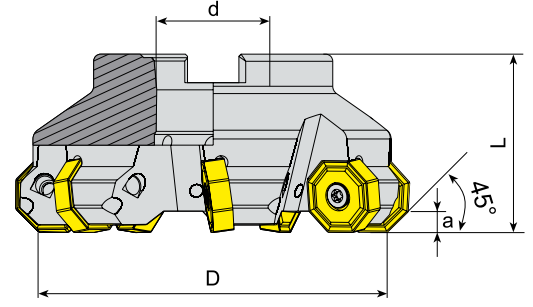

Takım Kodu Ordering Code	Stok Stock	Takım Ölçüleri (mm) Dimension (mm)					Kesici Uç Insert	Yedek Parçaları Spare Parts		
		D	Z	d	L	a		Sıkma Vidası Screw	Tork Anahtar Torx Key	Montaj Vidası Mounting Screw
AFM45-ON0806-D063-A22-Z05-H	●	63	5	22	40	4	ON.. 0806..	1020-M5x11	80-T20	2508-M10x30
AFM45-ON0806-D080-A27-Z06-H	●	80	6	27	50	4				2510-M12x35
AFM45-ON0806-D100-A32-Z07-H	●	100	7	32	50	4				2514-M16x35
AFM45-ON0806-D125-A40-Z08-H	●	125	8	40	63	4				-
AFM45-ON0806-D160-C40-Z10	●	160	10	40	63	4				-
AFM45-ON0806-D200-C60-Z12	●	200	12	60	63	4				-

ISO Ucuna Uygundur. / Compatible with ISO Insert.

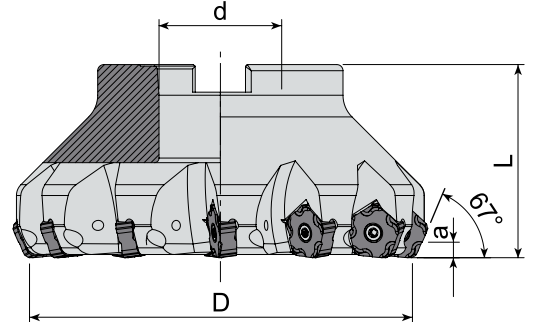

Takım Kodu Ordering Code	Stok Stock	Takım Ölçüleri (mm) Dimension (mm)					Kesici Uç Insert	Yedek Parçaları Spare Parts		
		D	Z	d	L	a		Sıkma Vidası Screw	Tork Anahtar Torx Key	Montaj Vidası Mounting Screw
AFM67-PN1105-D050-A22-Z05	●	50	5	22	50	5	PNEG 1105..	1515-M4x11	80-T15	2508-M10x30
AFM67-PN1105-D063-A22-Z06	●	63	6	22	50	5				2510-M12x35
AFM67-PN1105-D080-A27-Z08	●	80	8	27	50	5				-
AFM67-PN1105-D100-B32-Z10	●	100	10	32	50	5				-
AFM67-PN1105-D125-B40-Z12	●	125	12	40	63	5				-
AFM67-PN1105-D160-C40-Z14	●	160	14	40	63	5				-

R: Sağ/Right L: Sol/Left ● Stokta/In Stock ○ Stokta Yok/Non Stock Item
ZCC Ucuna Uygundur. / Compatible with ZCC Insert.

Sipariş Örneği/Ordering Example : 1 ad./pcs. AFM45-ON0806-D063-A22-Z05-H
Kesme Hesabı : S 229 / Cutting Calculation : P 229
Montaj Ölçüleri : S 227 / Mounting Reference : P 227

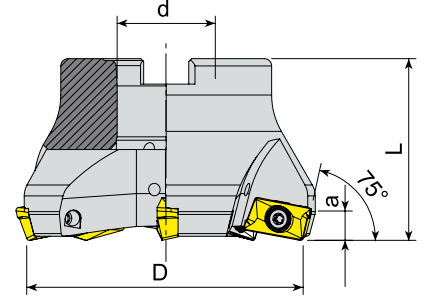

Takım Kodu Ordering Code	Stok Stock	Takım Ölçüleri (mm) Dimension (mm)					Kesici Uç Insert	Yedek Parçaları Spare Parts		
		D	Z	d	L	a		Sıkma Vidası Screw	Tork Anahtar Torx Key	Montaj Vidası Mounting Screw
AFM75-AP16-D063-A22-Z04-H	●	63	4	22	40	6	AP.. 1604..	1515-M4x11	80-T15	2508-M10x30
AFM75-AP16-D080-A27-Z05-H	●	80	5	27	50	6				2510-M12x35
AFM75-AP16-D100-A32-Z06-H	●	100	6	32	50	6				2514-M16x35
AFM75-AP16-D125-B40-Z07	●	125	7	40	63	6				-

ISO Ucuna Uygundur. / Compatible with ISO Insert.

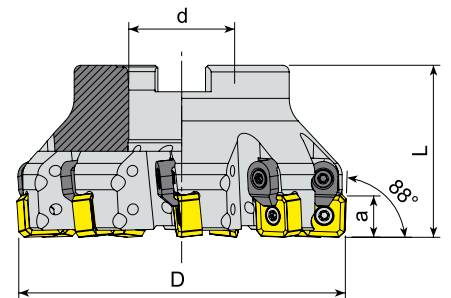

Takım Kodu Ordering Code	Stok Stock	Takım Ölçüleri (mm) Dimension (mm)					Kesici Uç Insert	Yedek Parçaları Spare Parts				
		D	Z	d	L	a		Sıkma Vidası Screw	Baskı Parçası Wedge Clamp	Baskı Vidası Clamp Screw	Tork Anahtar Torx Key	Montaj Vidası Mounting Screw
AFM88C-SN1206-D063-A22-Z06-H	●	63	6	22	40	11.5	SN.. 1206..	1615-M4x11	ACK-05	1515-M4x11	80-T15	2508-M10x30
AFM88C-SN1206-D080-A27-Z07-H	●	80	7	27	50	11.5						2510-M12x35
AFM88C-SN1206-D100-A32-Z09-H	●	100	9	32	52	11.5						2514-M16x35

R: Sağ/Right L: Sol/Left ● Stokta/In Stock ○ Stokta Yok/Non Stock Item
ISO Ucuna Uygundur. / Compatible with ISO Insert.

Sipariş Örneği/Ordering Example : 1 ad./pcs. AFM75-AP16-D063-A22-Z04-H
Kesme Hesabı : S 229 / Cutting Calculation : P 229
Montaj Ölçüleri : S 227 / Mounting Reference : P 227

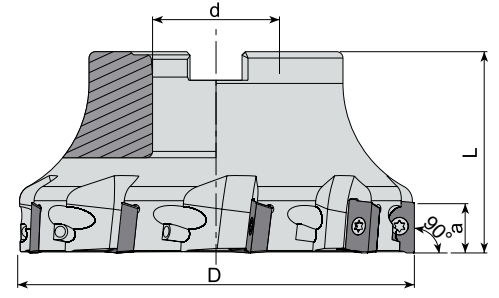

Takım Kodu Ordering Code	Stok Stock	Takım Ölçüleri (mm) Dimension (mm)					Kesici Uç Insert	Yedek Parçaları Spare Parts		
		D	Z	d	L	a		Sıkma Vidası Screw	Tork Anahtar Torx Key	Montaj Vidası Mounting Screw
AFM90-AD1505-D040-A16-Z04-H	●	40	4	16	40	15	AD.. 1505..	1515-M4x11	80-T15	2506-M8x30
AFM90-AD1505-D050-A22-Z05-H	●	50	5	22	40	15				2508-M10x30
AFM90-AD1505-D063-A22-Z06-H	●	63	6	22	40	15				2510-M12x35
AFM90-AD1505-D080-A27-Z07-H	●	80	7	27	50	15				2514-M16x35
AFM90-AD1505-D100-A32-Z08-H	●	100	8	32	50	15				-
AFM90-AD1505-D125-B40-Z09	●	125	9	40	63	15				-

ISCR Ucuna Uygun. / Compatible with ISCR Insert.

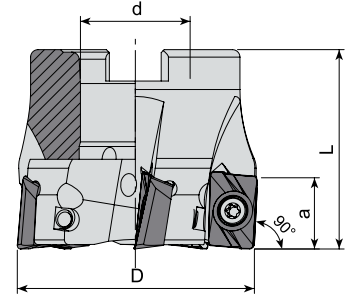

Takım Kodu Ordering Code	Stok Stock	Takım Ölçüleri (mm) Dimension (mm)					Kesici Uç Insert	Yedek Parçaları Spare Parts		
		D	Z	d	L	a		Sıkma Vidası Screw	Tork Anahtar Torx Key	Montaj Vidası Mounting Screw
AFM90-AD1505D-D050-A22-Z05-H	●	50	5	22	40	14.3	ADKT 150508	1515-M4x11	80-T15	2508-M10x30
AFM90-AD1505D-D063-A27-Z06-H	●	63	6	27	50	14.3				2510-M12x35
AFM90-AD1505D-D080-A27-Z08-H	●	80	8	27	50	14.3				-

R: Sağ/Right L: Sol/Left ● Stokta/In Stock ○ Stokta Yok/Non Stock Item
DJT Ucuna Uygun. / Compatible with DJT Insert.

Sipariş Örneği/Ordering Example : 1 ad./pcs. AFM90-AD1505-D040-A16-Z04-H
Kesme Hesabı : S 229 / Cutting Calculation : P 229
Montaj Ölçüleri : S 227 / Mounting Reference : P 227

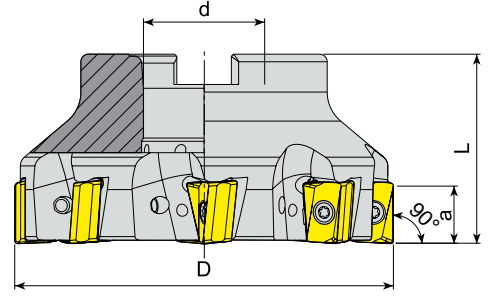

Takım Kodu Ordering Code	Stok Stock	Takım Ölçüleri (mm) Dimension (mm)					Kesici Uç Insert	Yedek Parçaları Spare Parts		
		D	Z	d	L	a		Sıkma Vidası Screw	Tork Anahtar Torx Key	Montaj Vidası Mounting Screw
AFM90-AN1607-D050-A22-Z04-H	●	50	4	22	40	15	AN.X 1607..	1515-M4x11	80-T15	2508-M10x30
AFM90-AN1607-D063-A22-Z06-H	●	63	6	22	40	15				
AFM90-AN1607-D080-A27-Z07-H	●	80	7	27	50	15				
AFM90-AN1607-D100-A32-Z08-H	●	100	8	32	50	15				

TGTC Ucuna Uygundur. / Compatiple with TGTC Insert.

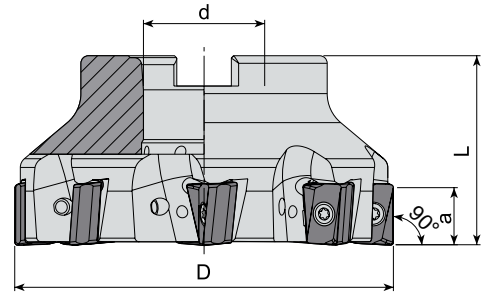

Takım Kodu Ordering Code	Stok Stock	Takım Ölçüleri (mm) Dimension (mm)					Kesici Uç Insert	Yedek Parçaları Spare Parts		
		D	Z	d	L	a		Sıkma Vidası Screw	Tork Anahtar Torx Key	Montaj Vidası Mounting Screw
AFM90-AN1506-D050-A22-Z04-H	●	50	4	22	40	14.5	ANGX 150608	4015-M4x12	80-T15	2508-M10x30
AFM90-AN1506-D063-A22-Z05-H	●	63	5	22	40	14.5				
AFM90-AN1506-D080-A27-Z06-H	●	80	6	27	50	14.5				
AFM90-AN1506-D100-A32-Z08-H	●	100	8	32	50	14.5				

R: Sağ/Right L: Sol/Left ● Stokta/In Stock ○ Stokta Yok/Non Stock Item
ZCC Ucuna Uygundur. / Compatiple with ZCC Insert.

Sipariş Örneği/Ordering Example : 1 ad./pcs. AFM90-AN1607-D050-A22-Z04-H
Kesme Hesabı : S-144 / Cutting Calculation : P-144
Montaj Ölçüleri : S 227 / Mounting Reference : P 227

90°

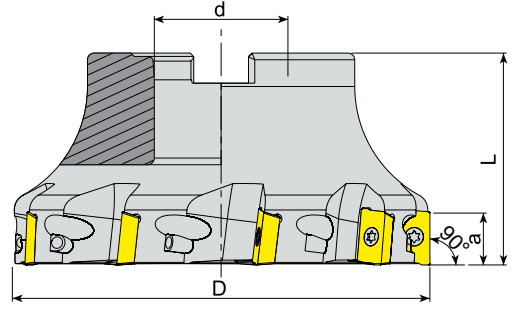

Takım Kodu Ordering Code	Stok Stock	Takım Ölçüleri (mm) Dimension (mm)					Kesici Uç Insert	Yedek Parçaları Spare Parts					
		D	Z	d	L	a		Sıkma Vidası Screw	Tork Anahtar Torx Key	Montaj Vidası Mounting Screw			
AFM90-AP10-D040-A16-Z05-H	●	40	5	16	40	10	AP.. 1003.. ISO UCUNA UYGUNDUR. FOR ISO INSERT.	3008-M2.5x6	80-T08	2506-M8x30			
AFM90-AP10-D050-A22-Z06-H	●	50	6	22	40	10				2508-M10x30			
AFM90-AP10-D063-A22-Z07-H	●	63	7	22	40	10				2510-M12x35			
AFM90-AP10-D080-A27-Z08-H	●	80	8	27	50	10				2514-M16x35			
AFM90-AP10-D100-A32-Z09-H	●	100	9	32	50	10	AP.. 1604.. ISO UCUNA UYGUNDUR. FOR ISO INSERT.	1515-M4x11	80-T15	2506-M8x30			
AFM90-AP16-D040-A16-Z04-H	●	40	4	16	40	16				2508-M10x30			
AFM90-AP16-D050-A22-Z05-H	●	50	5	22	40	16				2510-M12x35			
AFM90-AP16-D052-A22-Z05-H	●	52	5	22	40	16				2514-M16x35			
AFM90-AP16-D063-A22-Z06-H	●	63	6	22	40	16				-			
AFM90-AP16-D080-A27-Z07-H	●	80	7	27	50	16				2506-M8x30			
AFM90-AP16-D100-A32-Z08-H	●	100	8	32	50	16				2508-M10x30			
AFM90-AP16-D125-B40-Z09	●	125	9	40	63	16				2510-M12x35			
AFM90-AP16-D160-C40-Z10	●	160	10	40	63	16				2514-M16x35			
AFM90-AP16-D200-C60-Z12	●	200	12	60	63	16				-			
AFM90-AP16D-D050-A22-Z05-H	●	50	5	22	40	16				AP.. 1604.. - DJT	1515-M4x11	80-T15	2508-M10x30
AFM90-AP16L-D050-A22-Z05-H	●	50	5	22	40	16				AP.. 1604.. LMN UCUNA UYGUNDUR. FOR LMN INSERT.	1515-M4x11	80-T15	2510-M12x35
AFM90-AP16L-D063-A22-Z06-H	●	63	6	22	40	16	2506-M8x30						
AFM90-AP16L-D080-A27-Z07-H	●	80	7	27	50	16	2508-M10x30						
AFM90-AP16P-D040-A16-Z04-H	●	40	4	16	40	16	AP.. 1604.. PLBT UCUNA UYGUNDUR. FOR PLBT INSERT.	2510-M12x35					
AFM90-AP16P-D050-A22-Z05-H	●	50	5	22	40	16	AP.. 1604.. PLBT UCUNA UYGUNDUR. FOR PLBT INSERT.	1515-M4x11	80-T15	2514-M16x35			
AFM90-AP16P-D063-A22-Z06-H	●	63	6	22	40	16				2506-M8x30			
AFM90-AP16P-D080-A27-Z07-H	●	80	7	27	50	16				2508-M10x30			
AFM90-AP16P-D100-A32-Z08-H	●	100	8	32	50	16				2510-M12x35			
AFM90-AP1705-D050-A22-Z05-H	●	50	5	22	40	16	AP.. 1705.. TGTC-LMN UCUNA UYGUNDUR. FOR TGTC-LMN INSERT.	1515-M4x11	80-T15	2514-M16x35			
AFM90-AP1705-D063-A22-Z06-H	●	63	6	22	40	16	2508-M10x30						
AFM90-AP1705-D080-A27-Z07-H	●	80	7	27	50	16	2510-M12x35						
AFM90-AP1705-D100-A32-Z08-H	●	100	8	32	50	16	2514-M16x35						



R: Sağ/Right L: Sol/Left ● Stokta/In Stock ○ Stokta Yok/Non Stock Item

Sipariş Örneği/Ordering Example : 1 ad./pcs. AFM90-AP10-D040-A16-Z05-H

Kesme Hesabı : S 229 / Cutting Calculation : P 229

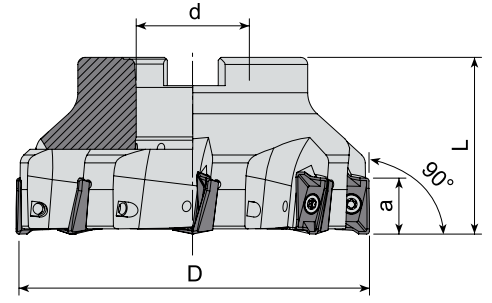

Montaj Ölçüleri : S 227 / Mounting Reference : P 227

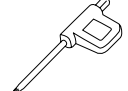

Takım Kodu Ordering Code	Stok Stock	Takım Ölçüleri (mm) Dimension (mm)					Kesici Uç Insert	Yedek Parçaları Spare Parts		
		D	Z	d	L	a		Sıkma Vidası Screw	Tork Anahtar Torx Key	Montaj Vidası Mounting Screw
AFM90-AX1705-D040-A16-Z04-H	●	40	4	16	40	14				2506-M8x30
AFM90-AX1705-D050-A22-Z05-H	●	50	5	22	40	14				2508-M10x30
AFM90-AX1705-D063-A22-Z06-H	●	63	6	22	40	14				2510-M12x35
AFM90-AX1705-D080-A27-Z07-H	●	80	7	27	50	14				2514-M16x35
AFM90-AX1705-D100-A32-Z08-H	●	100	8	32	50	14				

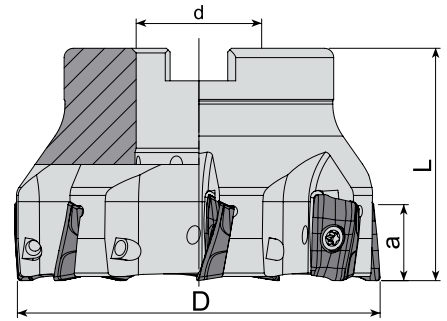
SMTM Ucuna Uygundur. / Compatible with SMTM Insert.



Takım Kodu Ordering Code	Stok Stock	Takım Ölçüleri (mm) Dimension (mm)					Kesici Uç Insert	Yedek Parçaları Spare Parts		
		D	Z	d	L	a		Sıkma Vidası Screw	Tork Anahtar Torx Key	Montaj Vidası Mounting Screw
AFM90-BD1704-D050-A22-Z05-H	●	50	5	22	40	15.7				2508-M10x30
AFM90-BD1704-D063-A22-Z06-H	●	63	6	22	40	15.7				2510-M12x35
AFM90-BD1704-D080-A27-Z07-H	●	80	7	27	50	15.7				

R: Sağ/Right L: Sol/Left ● Stokta/In Stock ○ Stokta Yok/Non Stock Item
KYCR Ucuna Uygundur. / Compatible with KYCR Insert.

Sipariş Örneği/Ordering Example : 1 ad./pcs. AFM90-AX1705-D040-A16-Z04-H
Kesme Hesabı : S 229 / Cutting Calculation : P 229
Montaj Ölçüleri : S 227 / Mounting Reference : P 227

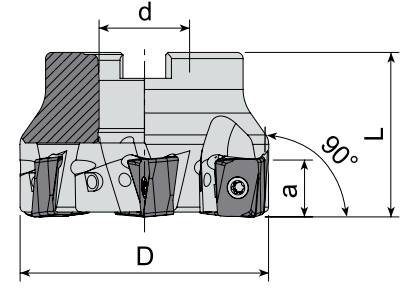

Takım Kodu Ordering Code	Stok Stock	Takım Ölçüleri (mm) Dimension (mm)					Kesici Uç Insert	Yedek Parçaları Spare Parts		
		D	Z	d	L	a		Sıkma Vidası Screw	Tork Anahtar Torx Key	Montaj Vidası Mounting Screw
AFM90-LN1307-D050-A22-Z04-H	●	50	4	22	40	13	LNKX 1307..	1315-M4x11	80-T15	2508-M10x30
AFM90-LN1307-D063-A22-Z06-H	●	63	6	22	40	13				2510-M12x35
AFM90-LN1307-D080-A27-Z07-H	●	80	7	27	50	13				2514-M16x35
AFM90-LN1307-D100-A32-Z08-H	●	100	8	32	50	13				-

WLTR Ucuna Uygundur. / Compatiple with WLTR Insert.

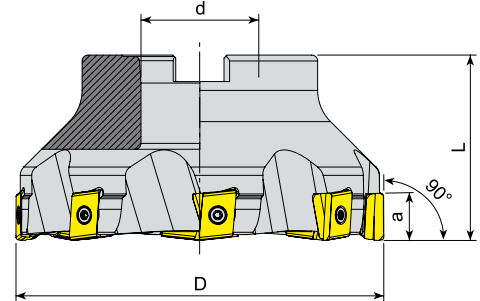

Takım Kodu Ordering Code	Stok Stock	Takım Ölçüleri (mm) Dimension (mm)					Kesici Uç Insert	Yedek Parçaları Spare Parts		
		D	Z	d	L	a		Sıkma Vidası Screw	Tork Anahtar Torx Key	Montaj Vidası Mounting Screw
AFM90-LN15Z-D050-A22-Z04	●	50	4	22	40	15	LNKT 1506..	1515-M4x11	80-T15	2508-M10x30
AFM90-LN15Z-D063-A22-Z05	●	63	5	22	40	15				2510-M12x35
AFM90-LN15Z-D080-A27-Z06	●	80	6	27	50	15				2514-M16x35
AFM90-LN15Z-D100-A32-Z07	●	100	7	32	50	15				-
AFM90-LN15Z-D125-B40-Z08	●	125	8	40	63	15				-

R: Sağ/Right L: Sol/Left ● Stokta/In Stock ○ Stokta Yok/Non Stock Item
ZCC Ucuna Uygundur. / Compatiple with ZCC Insert.

Sipariş Örneği/Ordering Example : 1 ad./pcs. AFM90-LN15Z-D050-A22-Z04
Kesme Hesabı : S 229 / Cutting Calculation : P 229
Montaj Ölçüleri : S 227 / Mounting Reference : P 227



90°

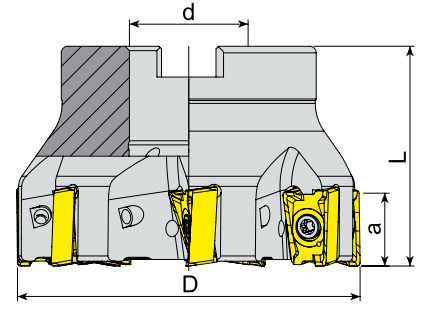

Takım Kodu Ordering Code	Stok Stock	Takım Ölçüleri (mm) Dimension (mm)					Kesici Uç Insert	Yedek Parçaları Spare Parts		
		D	Z	d	L	a		Sıkma Vidası Screw	Tork Anahtar Torx Key	Montaj Vidası Mounting Screw
AFM90-LN15T6-D050-A22-Z05-H	●	50	5	22	40	15.5	LNGU 15T6..	4015-M4x12	80-T15	2508-M10x30
AFM90-LN15T6-D063-A22-Z06-H	●	63	6	22	40	15.5				2510-M12x35
AFM90-LN15T6-D080-A27-Z07-H	●	80	7	27	50	15.5				

KNMTL Ucuna Uygundur. / Compatible with KNMTL Insert.

90°

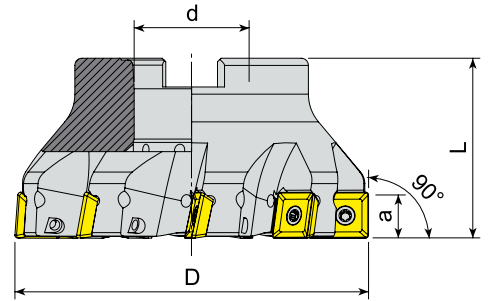

Takım Kodu Ordering Code	Stok Stock	Takım Ölçüleri (mm) Dimension (mm)					Kesici Uç Insert	Yedek Parçaları Spare Parts		
		D	Z	d	L	a		Sıkma Vidası Screw	Tork Anahtar Torx Key	Montaj Vidası Mounting Screw
AFM90-R290.12-D050-A22-Z04-H	●	50	4	22	40	10.7	R290-12T3..	4015-M3.5x11	80-T15	2508-M10x30
AFM90-R290.12-D063-A22-Z05-H	●	63	5	22	40	10.7				2510-M12x35
AFM90-R290.12-D080-A27-Z07-H	●	80	7	27	50	10.7				2514-M16x35
AFM90-R290.12-D100-A32-Z09-H	●	100	9	32	50	10.7				-
AFM90-R290.12-D125-B40-Z11	●	125	11	40	63	10.7				

R: Sağ/Right L: Sol/Left ● Stokta/In Stock ○ Stokta Yok/Non Stock Item
SNDVK Ucuna Uygundur. / Compatible with SNDVK Insert.

Sipariş Örneği/Ordering Example : 1 ad./pcs. AFM90-LN15T6-D050-A22-Z05-H
Kesme Hesabı : S 229 / Cutting Calculation : P 229
Montaj Ölçüleri : S 227 / Mounting Reference : P 227

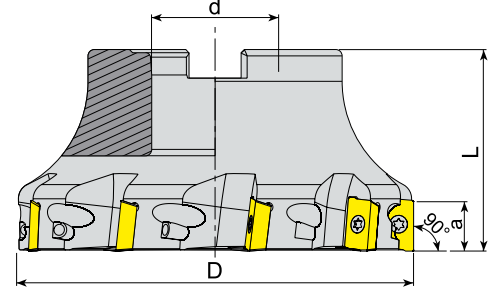

Takım Kodu Ordering Code	Stok Stock	Takım Ölçüleri (mm) Dimension (mm)					Kesici Uç Insert	Yedek Parçaları Spare Parts		
		D	Z	d	L	a		Sıkma Vidası Screw	Tork Anahtar Torx Key	Montaj Vidası Mounting Screw
AFM90-R390.11-D040-A16-Z05-H	●	40	5	16	40	10	R390-11T3..	3008-M2.5x6	80-T08	2506-M8x30
AFM90-R390.11-D050-A22-Z06-H	●	50	6	22	40	10				2508-M10x30
AFM90-R390.11-D063-A22-Z07-H	●	63	7	22	40	10				2510-M12x35
AFM90-R390.11-D080-A27-Z09-H	●	80	9	27	50	10				-
AFM90-R390.17-D040-A16-Z04-H	●	40	4	16	40	15.4	R390-1704..	4015-M3.5x11	80-T15	2506-M8x30
AFM90-R390.17-D050-A22-Z05-H	●	50	5	22	40	15.4				2508-M10x30
AFM90-R390.17-D063-A22-Z06-H	●	63	6	22	40	15.4				2510-M12x35
AFM90-R390.17-D080-A27-Z07-H	●	80	7	27	50	15.4				2514-M16x35
AFM90-R390.17-D100-A32-Z08-H	●	100	8	32	50	15.4				-
AFM90-R390.17-D125-B40-Z09	●	125	9	40	63	15.4	-	-	-	
AFM90-R390.18-D050-A22-Z04-H	●	50	4	22	40	15.4	R390-1806..	1515-M4x11	-	2508-M10x30
AFM90-R390.18-D063-A22-Z05-H	●	63	5	22	40	15.4				2510-M12x35
AFM90-R390.18-D080-A27-Z06-H	●	80	6	27	50	15.4				2514-M16x35
AFM90-R390.18-D100-A32-Z07-H	●	100	7	32	50	15.4				-
AFM90-R390.18-D125-B40-Z08	●	125	8	40	63	15.4				-

SNDVK Ucuna Uygunudur. / Compatible with SNDVK Insert.

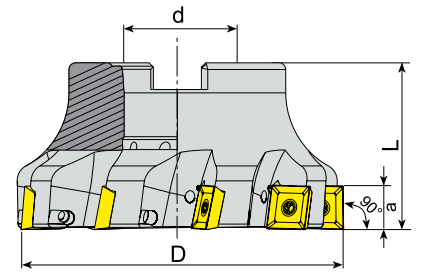

Takım Kodu Ordering Code	Stok Stock	Takım Ölçüleri (mm) Dimension (mm)					Kesici Uç Insert	Yedek Parçaları Spare Parts		
		D	Z	d	L	a		Sıkma Vidası Screw	Tork Anahtar Torx Key	Montaj Vidası Mounting Screw
AFM90-490R14-D050-A22-Z04-H	●	50	4	22	40	10	490R-1404..	4015-M3.5x11	80-T15	2508-M10x30
AFM90-490R14-D063-A22-Z05-H	●	63	5	22	40	10				2510-M12x35
AFM90-490R14-D080-A27-Z07-H	●	80	7	27	50	10				-

R: Sağ/Right L: Sol/Left ● Stokta/In Stock ○ Stokta Yok/Non Stock Item
SNDVK Ucuna Uygunudur. / Compatible with SNDVK Insert.

Sipariş Örneği/Ordering Example : 1 ad./pcs. AFM90-R390.11-D040-A16-Z05-H
Kesme Hesabı : S 229 / Cutting Calculation : P 229
Montaj Ölçüleri : S 227 / Mounting Reference : P 227

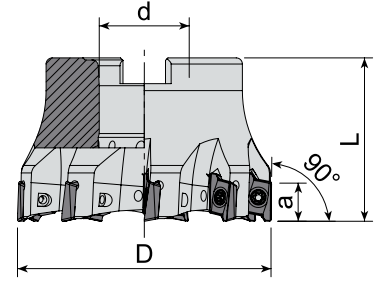

Takım Kodu Ordering Code	Stok Stock	Takım Ölçüleri (mm) Dimension (mm)					Kesici Uç Insert	Yedek Parçaları Spare Parts		
		D	Z	d	L	a		Sıkma Vidası Screw	Tork Anahtar Torx Key	Montaj Vidası Mounting Screw
AFM90-RT10-D040-A16-Z06-H	●	40	6	16	40	10	RT 1003..	3008-M2.5x6	80-T08	2506-M8x30
AFM90-RT10-D050-A22-Z07-H	●	50	7	22	40	10				2508-M10x30
AFM90-RT10-D063-A22-Z09-H	●	63	9	22	40	10				2508-M10x30

SFTY Ucuna Uygundur. / Compatiple with SFTY Insert.

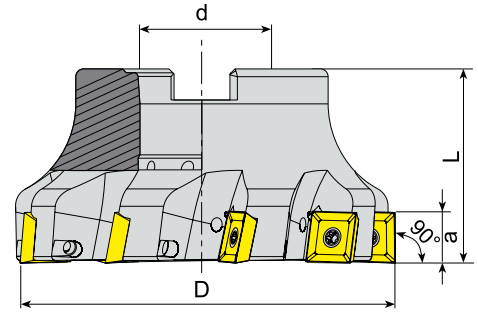

Takım Kodu Ordering Code	Stok Stock	Takım Ölçüleri (mm) Dimension (mm)					Kesici Uç Insert	Yedek Parçaları Spare Parts		
		D	Z	d	L	a		Sıkma Vidası Screw	Tork Anahtar Torx Key	Montaj Vidası Mounting Screw
AFM90-SD09M4-D040-A16-Z04-H	●	40	4	16	40	9	SD.. 09M4..	4015-M3.5x11	80-T15	2406-M8x30
AFM90-SD09M4-D050-A22-Z05-H	●	50	5	22	40	9				2508-M10x30
AFM90-SD09M4-D063-A22-Z06-H	●	63	6	22	40	9				2408-M10x30
AFM90-SD1305-D050-A22-Z04-H	●	50	4	22	40	13	SD.. 1305..	1020-M5x11	80-T20	2508-M10x30
AFM90-SD1305-D063-A22-Z05-H	●	63	5	22	40	13				2510-M12x35
AFM90-SD1305-D080-A27-Z06-H	●	80	6	27	50	13				2514-M16x35
AFM90-SD1305-D100-A32-Z07-H	●	100	7	32	50	13				-
AFM90-SD1305-D125-B40-Z08	●	125	8	40	63	13				-
AFM90-SD1305-D160-C40-Z10	●	160	10	40	63	13	-	-	-	

R: Sağ/Right L: Sol/Left ● Stokta/In Stock ○ Stokta Yok/Non Stock Item
KRLY Ucuna Uygundur. / Compatiple with KRLY Insert.

Sipariş Örneği/Ordering Example : 1 ad./pcs. AFM90-RT10-D040-A16-Z06-H
Kesme Hesabı : S 229 / Cutting Calculation : P 229
Montaj Ölçüleri : S 227 / Mounting Reference : P 227

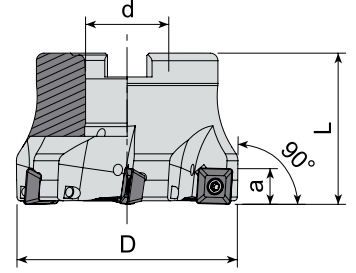

Takım Kodu Ordering Code	Stok Stock	Takım Ölçüleri (mm) Dimension (mm)					Kesici Uç Insert	Yedek Parçaları Spare Parts		
		D	Z	d	L	a		Sıkma Vidası Screw	Tork Anahtar Torx Key	Montaj Vidası Mounting Screw
AFM90-SE09-D040-A16-Z04-H	●	40	4	16	40	6.7	SEET 09T3..	1008-M3x8	80-T08	2506-M8x30
AFM90-SE09-D050-A22-Z05-H	●	50	5	22	40	6.7				2508-M10x30
AFM90-SE09-D063-A22-Z06-H	●	63	6	22	40	6.7				

ZCC Ucuna Uygundur. / Compatible with ZCC Insert.

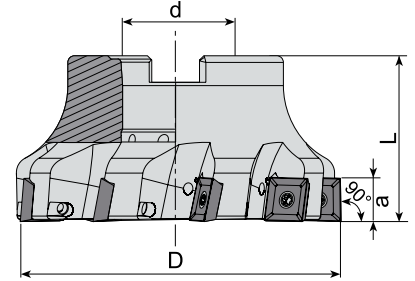

Takım Kodu Ordering Code	Stok Stock	Takım Ölçüleri (mm) Dimension (mm)					Kesici Uç Insert	Yedek Parçaları Spare Parts		
		D	Z	d	L	a		Sıkma Vidası Screw	Tork Anahtar Torx Key	Montaj Vidası Mounting Screw
AFM90-SE12-D050-A22-Z04-H	●	50	4	22	40	12	SEET 1203..	4015-M3.5x11	80-T15	2508-M10x30
AFM90-SE12-D063-A22-Z05-H	●	63	5	22	40	12				2510-M12x35
AFM90-SE12-D080-A27-Z07-H	●	80	7	27	50	12				2514-M16x35
AFM90-SE12-D100-A32-Z09-H	●	100	9	32	50	12				-
AFM90-SE12-D125-B40-Z11	●	125	11	40	63	12				

R: Sağ/Right L: Sol/Left ● Stokta/In Stock ○ Stokta Yok/Non Stock Item
ZCC Ucuna Uygundur. / Compatible with ZCC Insert.

Sipariş Örneği/Ordering Example : 1 ad./pcs. AFM90-SE09-D040-A16-Z04-H
Kesme Hesabı : S 229 / Cutting Calculation : P 229
Montaj Ölçüleri : S 227 / Mounting Reference : P 227

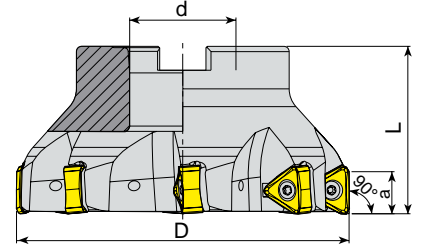

Takım Kodu Ordering Code	Stok Stock	Takım Ölçüleri (mm) Dimension (mm)					Kesici Uç Insert	Yedek Parçaları Spare Parts				
		D	Z	d	L	a		Sıkma Vidası Screw	Tork Anahtar Torx Key	Montaj Vidası Mounting Screw		
AFM90-TN2207-D063-A22-Z04-H	●	63	4	22	40	15	TN.X 2207..			2508-M10x30		
AFM90-TN2207-D080-A27-Z05-H	●	80	5	27	50	15				1120-M4.5x12	80-T20	2510-M12x35
AFM90-TN2207-D100-B32-Z06	●	100	6	32	50	15						
AFM90-TN2207-D125-B40-Z08	●	125	8	40	63	15						-

TGTC Ucuna Uygundur. / Compatible with TGTC Insert.

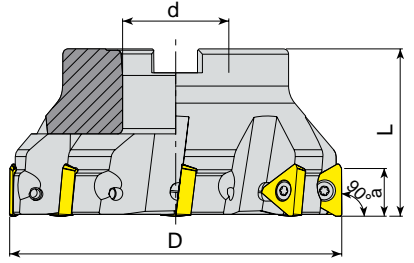

Takım Kodu Ordering Code	Stok Stock	Takım Ölçüleri (mm) Dimension (mm)					Kesici Uç Insert	Yedek Parçaları Spare Parts				
		D	Z	d	L	a		Sıkma Vidası Screw	Tork Anahtar Torx Key	Montaj Vidası Mounting Screw		
AFM90-TP2205-D063-A22-Z04	●	63	4	22	40	18	TPKT 2205..			2508-M10x30		
AFM90-TP2205-D080-A27-Z06	●	80	6	27	50	18				1120-M4.5x12	80-T20	2510-M12x35
AFM90-TP2205-D100-A32-Z07	●	100	7	32	50	18						2514-M16x35
AFM90-TP2205-D125-B40-Z08	●	125	8	40	63	18						
AFM90-TP2205-D160-C40-Z09	●	160	9	40	63	18						-
AFM90-TP2205-D200-C60-Z12	●	200	12	60	63	18						

R: Sağ/Right L: Sol/Left ● Stokta/In Stock ○ Stokta Yok/Non Stock Item
TGTC Ucuna Uygundur. / Compatible with TGTC Insert.

Sipariş Örneği/Ordering Example : 1 ad./pcs. AFM90-TN2207-D063-A22-Z04-H
Kesme Hesabı : S 229 / Cutting Calculation : P 229
Montaj Ölçüleri : S 227 / Mounting Reference : P 227

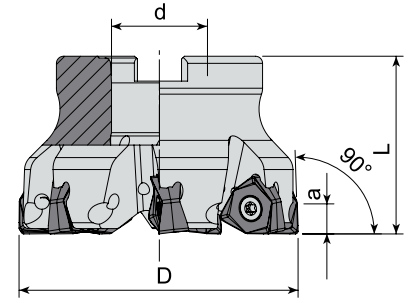

Takım Kodu Ordering Code	Stok Stock	Takım Ölçüleri (mm) Dimension (mm)					Kesici Uç Insert	Yedek Parçaları Spare Parts		
		D	Z	d	L	a		Sıkma Vidası Screw	Tork Anahtar Torx Key	Montaj Vidası Mounting Screw
AFM90-WN0806-D050-A16-Z04-H	●	50	4	16	40	8	WNMX 080608			2506-M8x30
AFM90-WN0806-D063-A22-Z05-H	●	63	5	22	40	8				2508-M10x30
AFM90-WN0806-D080-A27-Z07-H	●	80	7	27	50	8				2510-M12x35

KYCR-JD Ucuna Uygun. / Compatible with KYCR-JD Insert.

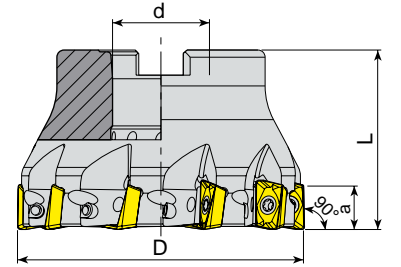

Takım Kodu Ordering Code	Stok Stock	Takım Ölçüleri (mm) Dimension (mm)					Kesici Uç Insert	Yedek Parçaları Spare Parts		
		D	Z	d	L	a		Sıkma Vidası Screw	Tork Anahtar Torx Key	Montaj Vidası Mounting Screw
AFM90-X012-D040-A16-Z05-H	●	40	5	16	40	11	XO.. 1204..			2506-M8x30
AFM90-X012-D050-A22-Z07-H	●	50	7	22	40	11				2508-M10x30
AFM90-X012-D063-A22-Z08-H	●	63	8	22	40	11				2510-M12x35
AFM90-X012-D080-A27-Z10-H	●	80	10	27	50	11				

R: Sağ/Right L: Sol/Left ● Stokta/In Stock ○ Stokta Yok/Non Stock Item
SC Ucuna Uygun. / Compatible with SC Insert.

Sipariş Örneği/Ordering Example : 1 ad./pcs. AFM90-WN0806-D050-A16-Z04-H
Kesme Hesabı : S 229 / Cutting Calculation : P 229
Montaj Ölçüleri : S 227 / Mounting Reference : P 227

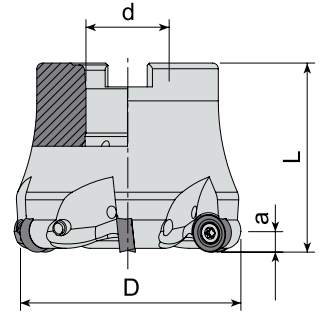

Takım Kodu Ordering Code	Stok Stock	Takım Ölçüleri (mm) Dimension (mm)					Kesici Uç Insert	Yedek Parçaları Spare Parts		
		D	Z	d	L	a		Sıkma Vidası Screw	Tork Anahtar Torx Key	Montaj Vidası Mounting Screw
AFMR-RC10T3-D040-A16-Z04-H	●	40	4	16	40	5	RC.. 10T3..	1515-M4x11	80-T15	2406-M8x30
AFMR-RC10T3-D050-A22-Z05-H	●	50	5	22	50	5				2508-M10x30
AFMR-RC10T3-D063-A22-Z06-H	●	63	6	22	50	5				

ZCC Ucuna Uygundur. / Compatiple with ZCC Insert.

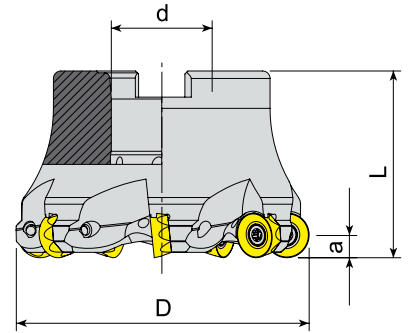

Takım Kodu Ordering Code	Stok Stock	Takım Ölçüleri (mm) Dimension (mm)					Kesici Uç Insert	Yedek Parçaları Spare Parts		
		D	Z	d	L	a		Sıkma Vidası Screw	Tork Anahtar Torx Key	Montaj Vidası Mounting Screw
AFMR-RC1204-D050-A22-Z05-H	●	50	5	22	50	6	RC.. 1204..	4015-M3.5x11	80-T15	2508-M10x30
AFMR-RC1204-D063-A22-Z06-H	●	63	6	22	50	6				2510-M12x35
AFMR-RC1204-D080-A27-Z07-H	●	80	7	27	50	6				

R: Sağ/Right L: Sol/Left ● Stokta/In Stock ○ Stokta Yok/Non Stock Item
SNDVK Ucuna Uygundur. / Compatiple with SNDVK Insert.

Sipariş Örneği/Ordering Example : 1 ad./pcs. AFMR-RC10T3-D040-A16-Z04-H
Kesme Hesabı : S 229 / Cutting Calculation : P 229
Montaj Ölçüleri : S 227 / Mounting Reference : P 227

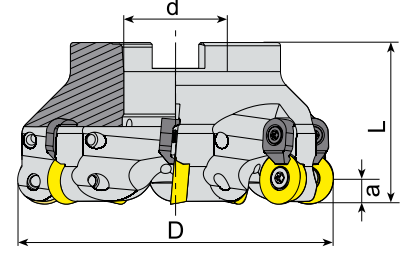

Takım Kodu Ordering Code	Stok Stock	Takım Ölçüleri (mm) Dimension (mm)					Kesici Uç Insert	Yedek Parçaları Spare Parts				
		D	Z	d	L	a		Sıkma Vidası Screw	Baskı Parçası Wedge Clamp	Baskı Vidası Clamp Screw	Tork Anahtar Torx Key	Montaj Vidası Mounting Screw
AFMR-RD0702-D050-A22-Z06-H	●	50	6	22	40	3.5	RD.. 0702..	3008-M2.5x6	-	-	80-T08	2407-M10x30
AFMR-RD0803-D050-A22-Z05-H	●	50	5	22	40	4	RD.. 0803..	1008-M3x8	-	-	80-T08	2406-M8x30
AFMRC-RD1003-D040-A16-Z04-H	●	40	4	16	40	5	RD.. 1003..					2406-M8x30
AFMRC-RD1003-D050-A22-Z05-H	●	50	5	22	40	5						2508-M10x30
AFMRC-RD1003-D063-A22-Z06-H	●	63	6	22	40	5						2510-M12x35
AFMRC-RD1003-D080-A27-Z07-H	●	80	7	27	50	5						2514-M16x35
AFMRC-RD1003-D100-A32-Z08-H	●	100	8	32	50	5						-
AFMRC-RD10T3-D050-A22-Z05-H	●	50	5	22	40	5						RD.. 10T3..
AFMRC-RD10T3-D063-A22-Z06-H	●	63	6	22	40	5	RD.. 12T3..	4015-M3.5x11	ACK-15	1015-M3.5x11	80-T15	2406-M8x30
AFMRC-RD12T3-D040-A16-Z04-H	●	40	4	16	40	6						2508-M10x30
AFMRC-RD12T3-D050-A22-Z05-H	●	50	5	22	40	6						2510-M12x35
AFMRC-RD12T3-D052-A22-Z05-H	●	52	5	22	40	6						2514-M16x35
AFMRC-RD12T3-D063-A22-Z06-H	●	63	6	22	40	6						-
AFMRC-RD12T3-D080-A27-Z07-H	●	80	7	27	50	6						2406-M8x30
AFMRC-RD12T3-D100-A32-Z08-H	●	100	8	32	50	6	RD.. 1204..					2508-M10x30
AFMRC-RD12T3-D125-B40-Z09	●	125	9	40	63	6						2510-M12x35
AFMRC-RD1204-D040-A16-Z04-H	●	40	4	16	40	6						2514-M16x35
AFMRC-RD1204-D050-A22-Z05-H	●	50	5	22	40	6						-
AFMRC-RD1204-D052-A22-Z05-H	●	52	5	22	40	6						2406-M8x30
AFMRC-RD1204-D063-A22-Z06-H	●	63	6	22	40	6						2508-M10x30
AFMRC-RD1204-D080-A27-Z07-H	●	80	7	27	50	6	2510-M12x35					
AFMRC-RD1204-D100-A32-Z07-H	●	100	7	32	50	6	RD.. 1604..	1515-M4.5x11	ACK-05	1515-M4x11		2514-M16x35
AFMRC-RD1204-D100-A32-Z08-H	●	100	8	32	50	6						2408-M10x30
AFMRC-RD1604-D050-A22-Z04-H	●	50	4	22	50	8						2508-M10x30
AFMRC-RD1604-D052-A22-Z04-H	●	52	4	22	50	8						2510-M12x35
AFMRC-RD1604-D063-A22-Z05-H	●	63	5	22	50	8						2514-M16x35
AFMRC-RD1604-D066-A22-Z05-H	●	66	5	22	50	8						-
AFMRC-RD1604-D066-A27-Z05-H	●	66	5	27	50	8	RD.. 1604..	1515-M4.5x11	ACK-05	1515-M4x11		2510-M12x35
AFMRC-RD1604-D080-A27-Z06-H	●	80	6	27	50	8						2408-M10x30
AFMRC-RD1604-D100-A32-Z07-H	●	100	7	32	50	8						2508-M10x30
AFMRC-RD1604-D100-A32-Z08-H	●	100	8	32	50	8						2510-M12x35
AFMRC-RD1604-D125-B40-Z07	●	125	7	40	63	8						2514-M16x35
AFMRC-RD1604-D125-B40-Z07	●	125	7	40	63	8						-

R: Sağ/Right L: Sol/Left ● Stokta/In Stock ○ Stokta Yok/Non Stock Item
ISO Ucuna Uygundur. / Compatible with ISO Insert.

Sipariş Örneği/Ordering Example : 1 ad./pcs. AFMR-RD0702-D050-A22-Z06-H

Kesme Hesabı : S 229 / Cutting Calculation : P 229

Montaj Ölçüleri : S 227 / Mounting Reference : P 227

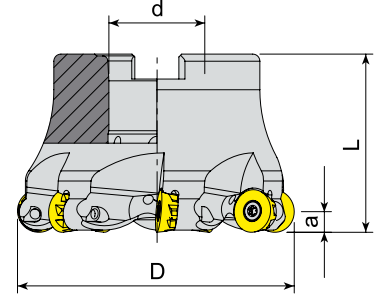

Takım Kodu Ordering Code	Stok Stock	Takım Ölçüleri (mm) Dimension (mm)					Kesici Uç Insert	Yedek Parçaları Spare Parts		
		D	Z	d	L	a		Sıkma Vidası Screw	Tork Anahtar Torx Key	Montaj Vidası Mounting Screw
AFMR-RP10T3-D063-A22-Z06-H	●	63	6	22	40	5	RPNX 10T3..	4010-M3x8	80-T10	2508-M10x30
AFMR-RP10T3-D080-A27-Z07-H	●	80	7	27	50	5				2510-M12x35
AFMR-RP1204-D040-A16-Z04-H	●	40	4	16	40	6	RPNX 1204..	4015-M3.5x11	80-T15	2406-M8x30
AFMR-RP1204-D080-A27-Z07-H	●	80	7	27	50	6				2510-M12x35

CRTZT Ucuna Uygunudur. / Compatiple with CRTZT Insert.

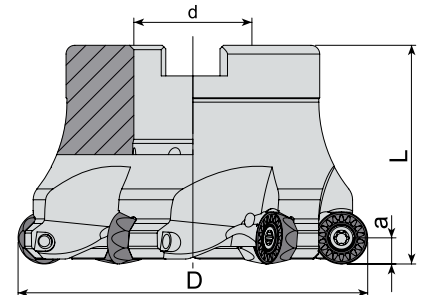

Takım Kodu Ordering Code	Stok Stock	Takım Ölçüleri (mm) Dimension (mm)					Kesici Uç Insert	Yedek Parçaları Spare Parts		
		D	Z	d	L	a		Sıkma Vidası Screw	Tork Anahtar Torx Key	Montaj Vidası Mounting Screw
AFMR-RP1204M-D063-A22-Z05-H	●	63	5	22	50	6	RPMT 1204..	1515-M4x11	80-T15	2508-M10x30
AFMR-RP1204M-D080-A27-Z06-H	●	80	6	27	50	6				2510-M12x35

R: Sağ/Right L: Sol/Left ● Stokta/In Stock ○ Stokta Yok/Non Stock Item
MTSBH Ucuna Uygunudur. / Compatiple with MTSBH Insert.

Sipariş Örneği/Ordering Example : 1 ad./pcs. AFMR-RP10T3-D063-A22-Z06-H

Kesme Hesabı : S 229 / Cutting Calculation : P 229

Montaj Ölçüleri : S 227 / Mounting Reference : P 227

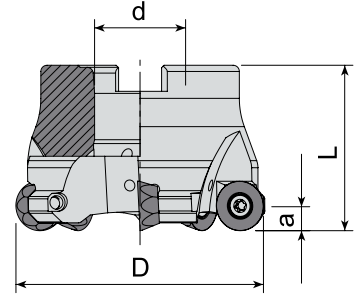

Takım Kodu Ordering Code	Stok Stock	Takım Ölçüleri (mm) Dimension (mm)					Kesici Uç Insert	Yedek Parçaları Spare Parts		
		D	Z	d	L	a		Sıkma Vidası Screw	Tork Anahtar Torx Key	Montaj Vidası Mounting Screw
AFMR-QP10T3-D040-A16-Z04-H	●	40	4	16	40	5	QP.. 10T3..	4015-M3.5x11	80-T15	2506-M8x30
AFMR-QP10T3-D050-A22-Z05-H	●	50	5	22	40	5				2407-M10x30
AFMR-QP10T3-D063-A22-Z06-H	●	63	6	22	40	5	QP.. 1204..	1515-M4x11	80-T15	2407-M10x30
AFMR-QP1204-D050-A22-Z04-H	●	50	4	22	40	6				2506-M8x30
AFMR-QP1204-D063-A22-Z05-H	●	63	5	22	40	6				2407-M10x30

R: Sağ/Right L: Sol/Left ● Stokta/In Stock ○ Stokta Yok/Non Stock Item
SMTM Ucuna Uyundur. / Compatible with SMTM Insert.

Sipariş Örneği/Ordering Example : 1 ad./pcs. AFMR-QP10T3-D040-A16-Z04-H
Kesme Hesabı : S 229 / Cutting Calculation : P 229
Montaj Ölçüleri : S 227 / Mounting Reference : P 227



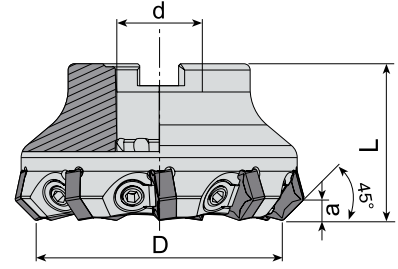

Takım Kodu Ordering Code	Stok Stock	Takım Ölçüleri (mm) Dimension (mm)					Kesici Uç Insert	Yedek Parçaları Spare Parts			
		D	Z	d	L	a		Baskı Pabucu Wedge Clamp	Baskı Vidası Clamp Screw	Anahtar Allen Key	Montaj Vidası Mounting Screw
AFM45C-HN0905-D063-A22-Z07	●	63	7	22	40	4.5	HN.. 0905..	ACK-11	AKV-15-M8x1x20	AAL-05-4	2508-M10x30
AFM45C-HN0905-D080-A27-Z09	●	80	9	27	50	4.5					2510-M12x35
AFM45C-HN0905-D100-A32-Z11	●	100	11	32	50	4.5					2514-M16x35
AFM45C-HN0905-D125-B40-Z13	●	125	13	40	63	4.5					-
AFM45C-HN0905-D160-C40-Z15	●	160	15	40	63	4.5					-

WDA-KNMTL Ucuna Uygunudur. / Compatiple with WDA-KNMTL Insert.

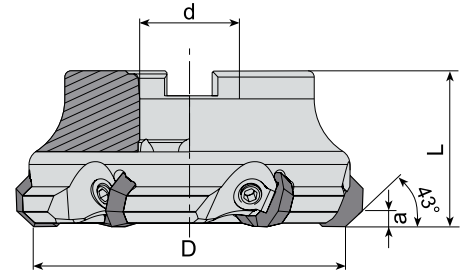

Takım Kodu Ordering Code	Stok Stock	Takım Ölçüleri (mm) Dimension (mm)					Kesici Uç Insert	Yedek Parçaları Spare Parts			
		D	Z	d	L	a		Baskı Pabucu Wedge Clamp	Baskı Vidası Clamp Screw	Anahtar Allen Key	Montaj Vidası Mounting Screw
AFM43C-OF07-D063-A22-Z04	●	63	4	22	45	5	OF.. 0704..	ACK-11	AKV-15-M8x1x20	AAL-05-4	2508-M10x30
AFM43C-OF07-D080-A27-Z05	●	80	5	27	50	5					2510-M12x35
AFM43C-OF07-D100-A32-Z06	●	100	6	32	50	5					2514-M16x35
AFM43C-OF07-D125-B40-Z08	●	125	8	40	63	5					-
AFM43C-OF07-D160-C40-Z09	●	160	9	40	63	5					-

R: Sağ/Right L: Sol/Left ● Stokta/In Stock ○ Stokta Yok/Non Stock Item
ISO Ucuna Uygunudur. / Compatiple with ISO Insert.

Sipariş Örneği/Ordering Example : 1 ad./pcs. AFM45C-HN0905-D063-A22-Z07
Kesme Hesabı : S 229 / Cutting Calculation : P 229
Montaj Ölçüleri : S 227 / Mounting Reference : P 227

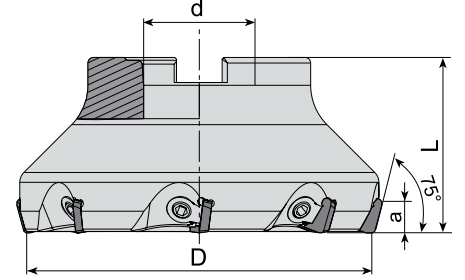

Takım Kodu Ordering Code	Stok Stock	Takım Ölçüleri (mm) Dimension (mm)					Kesici Uç Insert	Yedek Parçaları Spare Parts				
		D	Z	d	L	a		Baskı Pabucu Wedge Clamp	Baskı Vidası Clamp Screw	Anahtar Allen Key	Montaj Vidası Mounting Screw	
AFM75C-SP12-D050-A22-Z04	●	50	4	22	42	8	SPKN 1203..	ACK-10	AKV-13-M8x1x16	AAL-05-4	2508-M10x30	
AFM75C-SP12-D063-A22-Z05	●	63	5	22	40	8						2510-M12x35
AFM75C-SP12-D080-A27-Z06	●	80	6	27	50	8						2514-M16x35
AFM75C-SP12-D100-A32-Z07	●	100	7	32	50	8						-
AFM75C-SP12-D125-B40-Z08	●	125	8	40	63	8						-
AFM75C-SP12-D160-C40-Z09	●	160	9	40	63	8						-
AFM75C-SP12-D200-C60-Z12	●	200	12	60	63	8						-

ISO Ucuna Uygundur. / Compatible with ISO Insert.

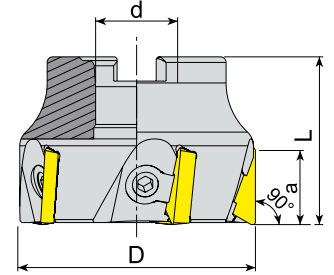

Takım Kodu Ordering Code	Stok Stock	Takım Ölçüleri (mm) Dimension (mm)					Kesici Uç Insert	Yedek Parçaları Spare Parts			
		D	Z	d	L	a		Baskı Pabucu Wedge Clamp	Baskı Vidası Clamp Screw	Anahtar Allen Key	Montaj Vidası Mounting Screw
AFM90C-TP16-D050-A22-Z04	●	50	4	22	40	12	TP.. 1603..	ACK-10	AKV-22-M8x1x14 AKV-13-M8x1x16	AAL-05-4	2408-M10x30
AFM90C-TP16-D063-A22-Z06	●	63	6	22	45	12					2508-M10x30
AFM90C-TP16-D080-A27-Z07	●	80	7	27	50	12					2510-M12x35
AFM90C-TP16-D100-A32-Z08	●	100	8	32	50	12					2514-M16x35
AFM90C-TP22-D063-A22-Z05	●	63	5	22	45	18	TP.. 2204..	ACK-11	AKV-14-M8x1x18	AAL-05-4	2508-M10x30
AFM90C-TP22-D080-A27-Z06	●	80	6	27	50	18					2510-M12x35
AFM90C-TP22-D100-A32-Z07	●	100	7	32	50	18					2514-M16x35
AFM90C-TP22-D125-B40-Z08	●	125	8	40	63	18					-
AFM90C-TP22-D160-C40-Z09	●	160	9	40	63	18					-
AFM90C-TP22-D200-C60-Z12	●	200	12	60	63	18					-
AFM90C-TP22-D250-C60-Z15	●	250	15	60	63	18					-
AFM90C-TP22-D315-D60-Z18	●	315	18	60	63	18					-

R: Sağ/Right L: Sol/Left ● Stokta/In Stock ○ Stokta Yok/Non Stock Item
ISO Ucuna Uygundur. / Compatible with ISO Insert.

Sipariş Örneği/Ordering Example : 1 ad./pcs. AFM75C-SP12-D050-A22-Z04

Kesme Hesabı : S 229 / Cutting Calculation : P 229

Montaj Ölçüleri : S 227 / Mounting Reference : P 227

new

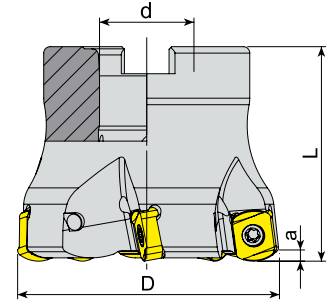

Takım Kodu Ordering Code	Stok Stock	Takım Ölçüleri (mm) Dimension (mm)					Kesici Uç Insert	Yedek Parçaları Spare Parts		
		D	Z	d	L	a		Sıkma Vidası Screw	Tork Anahtar Torx Key	Montaj Vidası Mounting Screw
AHFM-BL0904-D050-A22-Z06-H	●	50	6	22	50	2	BLMP 0904..			2508-M10x30
AHFM-BL0904-D063-A22-Z05-H	●	63	5	22	50	2				
AHFM-BL0904-D063-A22-Z07-H	●	63	7	22	50	2				

TGTC Ucuna Uygunudur. / Compatible with TGTC Insert.

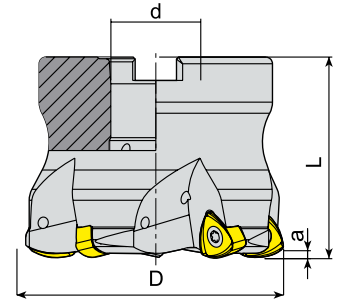

Takım Kodu Ordering Code	Stok Stock	Takım Ölçüleri (mm) Dimension (mm)					Kesici Uç Insert	Yedek Parçaları Spare Parts		
		D	Z	d	L	a		Sıkma Vidası Screw	Tork Anahtar Torx Key	Montaj Vidası Mounting Screw
AHFM-BL1205-D050-A22-Z03-H	●	50	3	22	40	2	BLMP 1205..			2508-M10x30
AHFM-BL1205-D063-A22-Z04-H	●	63	4	22	40	2				
AHFM-BL1205-D080-A27-Z05-H	●	80	5	27	50	2				2510-M12x35

R: Sağ/Right L: Sol/Left ● Stokta/In Stock ○ Stokta Yok/Non Stock Item
TGTC Ucuna Uygunudur. / Compatible with TGTC Insert.

Sipariş Örneği/Ordering Example : 1 ad./pcs. AHFM-BL0904-D050-A22-Z06-H
Kesme Hesabı : S 229 / Cutting Calculation : P 229
Montaj Ölçüleri : S 227 / Mounting Reference : P 227

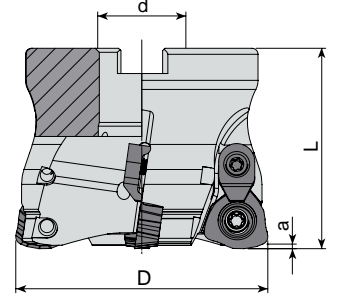

Takım Kodu Ordering Code	Stok Stock	Takım Ölçüleri (mm) Dimension (mm)					Kesici Uç Insert	Yedek Parçaları Spare Parts				
		D	Z	d	L	a		Sıkma Vidası Screw	Baskı Parçası Wedge Clamp	Baskı Vidası Clamp Screw	Tork Anahtar Torx Key	Montaj Vidası Mounting Screw
AHFMC-JD1204-D052-A22-Z03-H	●	52	3	22	50	1.5	JDMW 1204..	1615-M4x11	ACK-05	1515-M4x11	80-T15	2508-M10x30
AHFMC-JD1204-D052-A22-Z04-H	●	52	4	22	50	1.5						
AHFMC-JD1405-D052-A22-Z03-H	●	52	3	22	40	2	JDMW 1405..	1020-M5x11	ACK-05	1515-M4x11	80-T20	2408-M10x30
AHFMC-JD1405-D063-A22-Z04-H	●	63	4	22	40	2						2508-M10x30

MTSBH Ucuna Uygunudur. / Compatible with MTSBH Insert.

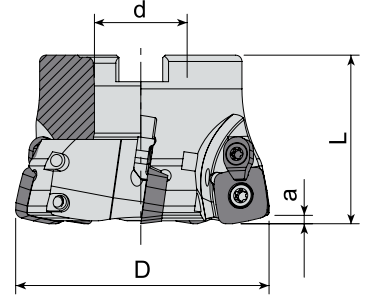

Takım Kodu Ordering Code	Stok Stock	Takım Ölçüleri (mm) Dimension (mm)					Kesici Uç Insert	Yedek Parçaları Spare Parts				
		D	Z	d	L	a		Sıkma Vidası Screw	Baskı Parçası Wedge Clamp	Baskı Vidası Clamp Screw	Tork Anahtar Torx Key	Montaj Vidası Mounting Screw
AHFMC-SD1204-D050-A22-Z04-H	●	50	4	22	40	1.8	SD.. 1204..	1515-M4x11	ACK-15	1015-M3.5x11	80-T15	2508-M10x30
AHFMC-SD1204-D063-A22-Z05-H	●	63	5	22	40	1.8						
AHFMC-SD1204-D080-A27-Z06-H	●	80	6	27	50	1.8						2510-M12x35
AHFMC-SD1204-D100-A32-Z08-H	●	100	8	32	50	1.8						2514-M16x35

R: Sağ/Right L: Sol/Left ● Stokta/In Stock ○ Stokta Yok/Non Stock Item
ZCC Ucuna Uygunudur. / Compatible with ZCC Insert.

Sipariş Örneği/Ordering Example : 1 ad./pcs. AHFMC-JD1204-D052-A22-Z03-H
Kesme Hesabı : S 229 / Cutting Calculation : P 229
Montaj Ölçüleri : S 227 / Mounting Reference : P 227

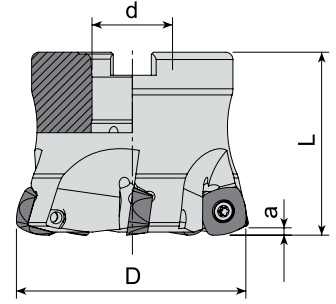

Takım Kodu Ordering Code	Stok Stock	Takım Ölçüleri (mm) Dimension (mm)					Kesici Uç Insert	Yedek Parçaları Spare Parts		
		D	Z	d	L	a		Sıkma Vidası Screw	Tork Anahtar Torx Key	Montaj Vidası Mounting Screw
AHFM-SD1205-D052-A22-Z04-H	●	52	4	22	50	2	SD.. 1205..	1515-M4x11	80-T15	2508-M10x30
AHFM-SD1205-D052-A22-Z05-H	●	52	5	22	50	2				
AHFM-SD1205-D066-A22-Z05-H	●	66	5	22	50	2				
AHFM-SD1205-D066-A22-Z06-H	●	66	6	22	50	2				
AHFM-SD1205-D080-A27-Z06-H	●	80	6	27	70	2				

HTCH Ucuna Uygunudur. / Compatible with HTCH Insert.

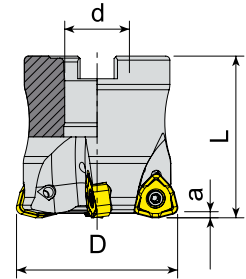

Takım Kodu Ordering Code	Stok Stock	Takım Ölçüleri (mm) Dimension (mm)					Kesici Uç Insert	Yedek Parçaları Spare Parts		
		D	Z	d	L	a		Sıkma Vidası Screw	Tork Anahtar Torx Key	Montaj Vidası Mounting Screw
AHFM-WN09T3-D040-A16-Z04-H	●	40	4	16	40	1.5	WNMX 09T3..	4010-M3x8	80-T10	2506-M8x30
AHFML-WN09T3-D040-A16-Z04-H	●	40	4	16	40	1.5				
AHFM-WN09T3-D050-A22-Z05-H	●	50	5	22	40	1.5				
AHFML-WN09T3-D050-A22-Z05-H	●	50	5	22	40	1.5				
AHFM-WN09T3-D063-A22-Z06-H	●	63	6	22	40	1.5				2508-M10x30

R: Sağ/Right L: Sol/Left ● Stokta/In Stock ○ Stokta Yok/Non Stock Item
KRLY Ucuna Uygunudur. / Compatible with KRLY Insert.

Sipariş Örneği/Ordering Example : 1 ad./pcs. AHFM-SD1205-D052-A22-Z04-H
Kesme Hesabı : S 229 / Cutting Calculation : P 229
Montaj Ölçüleri : S 227 / Mounting Reference : P 227

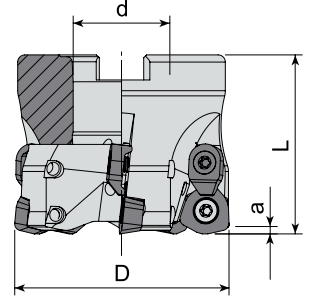

Takım Kodu Ordering Code	Stok Stock	Takım Ölçüleri (mm) Dimension (mm)					Kesici Uç Insert	Yedek Parçaları Spare Parts				
		D	Z	d	L	a		Sıkma Vidası Screw	Baskı Parçası Wedge Clamp	Baskı Vidası Clamp Screw	Tork Anahtar Torx Key	Montaj Vidası Mounting Screw
AHFMC-WD0804-D040-A16-Z04-H	●	40	4	16	40	-	WDMT 0804..	4010-M3x8	ACK-15	4010-M3x8	80-T10	2506-M8x30
AHFMC-WD1205-D050-A22-Z04-H	●	50	4	22	50	-	WDMT 1205..	1415-M4x11	ACK-05	1515-M4x11	80-T15	2508-M10x30
AHFMC-WD1205-D063-A22-Z05-H	●	63	5	22	50	-						2510-M12x35
AHFMC-WD1205-D080-A27-Z06-H	●	80	6	27	63	-						2510-M12x35

SMTM Ucuna Uygun. / Compatiple with SMTM Insert.

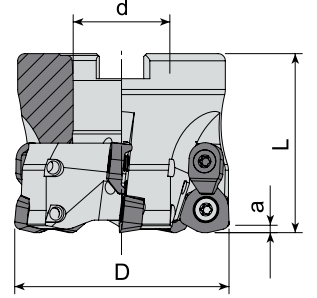

Takım Kodu Ordering Code	Stok Stock	Takım Ölçüleri (mm) Dimension (mm)					Kesici Uç Insert	Yedek Parçaları Spare Parts				
		D	Z	d	L	a		Sıkma Vidası Screw	Baskı Parçası Wedge Clamp	Baskı Vidası Clamp Screw	Tork Anahtar Torx Key	Montaj Vidası Mounting Screw
AHFMC-WD06T3D-D042-A16-Z04-H	●	42	4	16	45	1.5	WDMT 06T3..	3015-M3.5x9	ACK-15	1015-M3.5x11	80-T15	2506-M8x30
AHFMC-WD06T3D-D050-A22-Z05-H	●	50	5	22	50	1.5						2508-M10x30
AHFMC-WD06T3D-D052-A22-Z05-H	●	52	5	22	50	1.5						2510-M12x35
AHFMC-WD0805D-D052-A22-Z04-H	●	52	4	22	50	2	WDMT 0805..	4020-M4.5x12	ACK-19	4020-M4.5x12	80-T20	2510-M12x35
AHFMC-WD0805D-D063-A27-Z05-H	●	63	5	27	50	2						2510-M12x35

R: Sağ/Right L: Sol/Left ● Stokta/In Stock ○ Stokta Yok/Non Stock Item
DJT Ucuna Uygun. / Compatiple with DJT Insert.

Sipariş Örneği/Ordering Example : 1 ad./pcs. AHFMC-WD0804-D040-A16-Z04-H
Kesme Hesabı : S 229 / Cutting Calculation : P 229
Montaj Ölçüleri : S 227 / Mounting Reference : P 227

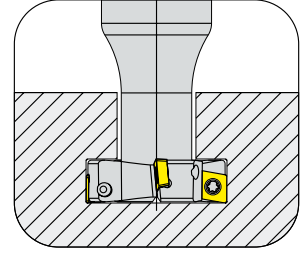
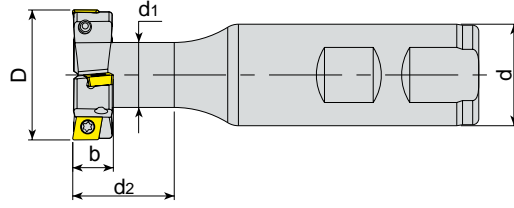

Takım Kodu
Ordering Code

Takım Kodu Ordering Code	Stok Stock	Takım Ölçüleri (mm) Dimension (mm)							Yedek Parçaları Spare Parts			
		Z		D	b	d	L	d ₁	d ₂	Kesici Uç Insert	Sıkma Vidası Screw	Tork Anahtar Torx Key
		Toplam Total	Etkili Effective									
ATSM90-CC06-D17X8-W16-L85-Z02	●	2	1	17	8	16	85	10	16	CC.. 0602..	3008-M2.5x6	80-T08
ATSM90-CC06-D32X8-W25-L100-Z04	●	4	2	32	8	25	100	16	23			
ATSM90-CC06-D63X8-W32-L125-Z08	●	8	4	63	8	32	125	31.5	30			
ATSM90-CC06-D18X9-W16-L90-Z02	●	2	1	18	9	16	90	10	16			
ATSM90-CC06-D20X9-W16-L85-Z04	●	4	2	20	9	16	85	10	16			
ATSM90-CC06-D23X10-W20-L90-Z04	●	4	2	23	10	20	90	12	25			
ATSM90-CC06-D32X10-W25-L100-Z04	●	4	2	32	10	25	100	16	25			
ATSM90-CC06-D45X10-W32-L120-Z06	●	6	3	45	10	32	120	20	25			
ATSM90-CC06-D25X11-W25-L100-Z04	●	4	2	25	11	25	100	13	20			
ATSM90-CC09-D30X12-W25-L100-Z04	●	4	2	30	12	25	100	16	25	CC.. 09T3..	4015-M3.5x9	80-T15
ATSM90-CC09-D32X12-W25-L100-Z02	●	2	1	32	12	25	100	16	25			
ATSM90-CC09-D32X12-W25-L100-Z04	●	4	2	32	12	25	100	16	25			
ATSM90-CC09-D32X14-W25-L100-Z04	●	4	2	32	14	25	100	16	25			
ATSM90-CC09-D37X16-W32-L120-Z04	●	4	2	37	16	32	120	17	30			
ATSM90-CC09-D42X17-W32-L120-Z04	●	4	2	42	17	32	120	19	30			
ATSM90-CC09-D40X17-W32-L120-Z04-H	●	4	2	40	17	32	120	19	30			
ATSM90-CC12-D47X20-W32-L120-Z04	●	4	2	47	20	32	120	25	45	CC.. 1204..	1020-M5x11	80-T20
ATSM90-CC12-D52X21-W32-L120-Z04	●	4	2	52	21	32	120	25	45			
ATSM90-CC12-D50X22-W32-L120-Z04	●	4	2	50	22	32	120	25	45			
ATSM90-CC12-D55X22-W32-L120-Z04	●	4	2	55	22	32	120	25	45			

R: Sağ/Right L: Sol/Left ● Stokta/In Stock ○ Stokta Yok/Non Stock Item

Sipariş Örneği/Ordering Example : 1 ad./pcs. ATSM90-CC06-D17X8-W16-L85-Z02
Kesme Hesabı : S 229 / Cutting Calculation : P 229



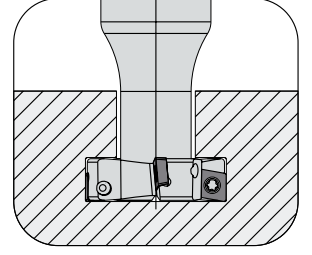
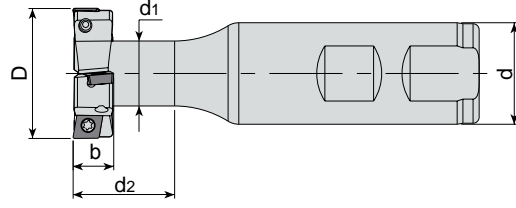

Takım Kodu Ordering Code	Stok Stock	Takım Ölçüleri (mm) Dimension (mm)								Yedek Parçaları Spare Parts		
		Z		D	b	d	L	d ₁	d ₂	Kesici Uç Insert	Sıkma Vidası Screw	Tork Anahtar Torx Key
		Toplam Total	Etkili Effective									
ATSM90-SPGT0904-D37X16-W32-L120-Z04-H	●	4	2	37	16	32	120	21	40	SPGT 090408 ZCC UCUNA UYGUNDUR. FOR ZCC INSERT.	4015-M3.5x9	80-T15
ATSM90-SPGT0904-D42X17-W32-L120-Z04-H	●	4	2	42	17	32	120	21	40			
ATSM90-SPGT1104-D47X20-W32-L120-Z04-H	●	4	2	47	20	32	120	24	45	SPGT 110408	1515-M4x11	
ATSM90-SP..06-D80X7-W32-L120-Z10	●	10	5	80	7	32	120	32	30	SPMG 060204 TGTC UCUNA UYGUNDUR. FOR TGTC INSERT.	3007-M2.2x5	80-T07

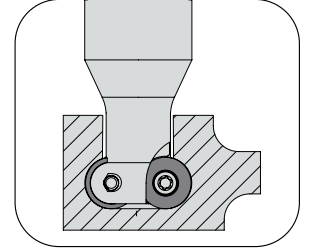
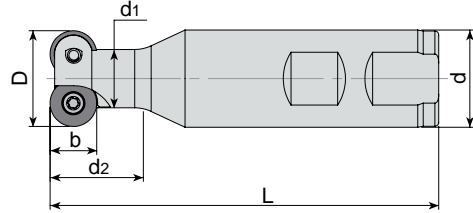

Takım Kodu Ordering Code	Stok Stock	Takım Ölçüleri (mm) Dimension (mm)								Yedek Parçaları Spare Parts		
		Z	D	b	d	L	d ₁	d ₂	Kesici Uç Insert	Sıkma Vidası Screw	Tork Anahtar Torx Key	
ATSMR-RD0702-D17-W16-L90-Z02	●	2	17	7	16	90	10	12	RD.. 0702	3008-M2.5x6	80-T08	
ATSMR-RD0702-D25-W16-L90-Z03	●	3	25	7	16	90	15	12				
ATSMR-RD0702-D35-W25-L100-Z05	●	5	35	7	25	100	20	20	RD.. 1003	4015-M3.5x9	80-T15	
ATSMR-RD1003-D21-W25-L100-Z02	●	2	21	10	25	100	12	20				
ATSMR-RD12T3-D25-W25-L100-Z02	●	2	25	12	25	100	15	24	RD.. 12T3			
ATSMR-RD1604-D34-W32-L110-Z02	●	2	34	16	32	110	20	30	RD.. 1604	1515-M4.5x11		

R: Sağ/Right L: Sol/Left ● Stokta/In Stock ○ Stokta Yok/Non Stock Item

Sipariş Örneği/Ordering Example : 1 ad./pcs. ATSM90-SPGT0904-D37X16-W32-L120-Z04-H
Kesme Hesabı : S 229 / Cutting Calculation : P 229

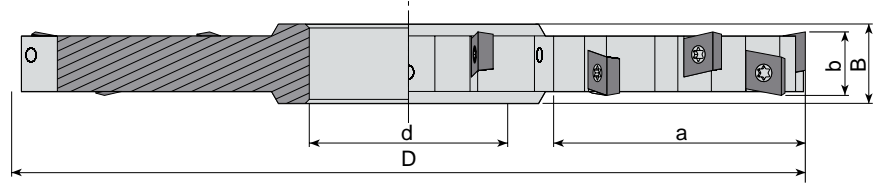

Takım Kodu Ordering Code	Stok Stock	Takım Ölçüleri (mm) Dimension (mm)							Yedek Parçaları Spare Parts		
		Z		D	b	a	d	B	Kesici Uç Insert	Sıkma Vidası Screw	Tork Anahtar Torx Key
		Toplam Total	Etkili Effective								
ASDM-SPGT05-D80x6-d27-Z10	●	10	5	80	6	17	27	10	SPGT 050204 ZCC UCUNA UYGUNDUR. FOR ZCC INSERT.	3006-M2x4	80-T06
ASDM-SPGT05-D100x6-d32-Z12	●	12	6	100	6	25	32	10			
ASDM-SPGT05-D125x6-d40-Z14	●	14	7	125	6	35	40	10			
ASDM-SPGT05-D160x6-d40-Z18	●	18	9	160	6	52	40	10			
ASDM-SPGT06-D80x7-d27-Z10	●	10	5	80	7	17	27	11	SPGT 060204 ZCC UCUNA UYGUNDUR. FOR ZCC INSERT.	3007-M2.2x5	80-T07
ASDM-SPGT06-D100x7-d32-Z12	●	12	6	100	7	25	32	11			
ASDM-SPGT06-D125x7-d40-Z14	●	14	7	125	7	35	40	11			
ASDM-SPGT06-D160x7-d40-Z16	●	16	8	160	7	52	40	11			
ASDM-SPGT06-D200x7-d40-Z18	●	18	9	200	7	70	40	11			

R: Sağ/Right L: Sol/Left ● Stokta/In Stock ○ Stokta Yok/Non Stock Item

Sipariş Örneği/Ordering Example : 1 ad./pcs. ASDM-SPGT05-D80x6-d27-Z10
Kesme Hesabı : S 229 / Cutting Calculation : P 229



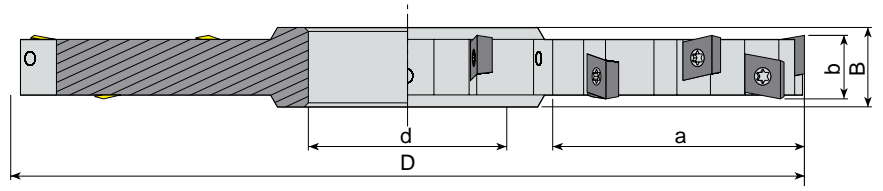

Takım Kodu
Ordering Code

Takım Kodu Ordering Code	Stok Stock	Takım Ölçüleri (mm) Dimension (mm)						Yedek Parçaları Spare Parts			
		Z		D	b	a	d	B	Kesici Uç Insert	Sıkma Vidası Screw	Tork Anahtar Torx Key
		Toplam Total	Etkili Effective								
ASDM-CC06-D80x8-d27-Z10	●	10	5	80	8	17	27	12	CC.. 0602.. ISO UCUNA UYGUNDUR. FOR ISO INSERT.	3008-M2.5x6	80-T08
ASDM-CC06-D100x8-d32-Z12	●	12	6	100	8	25	32	12			
ASDM-CC06-D125x8-d40-Z14	●	14	7	125	8	35	40	12			
ASDM-CC06-D160x8-d40-Z16	●	16	8	160	8	52	40	12			
ASDM-CC06-D200x8-d40-Z18	●	18	9	200	8	70	40	12			
ASDM-CC06-D80x10-d27-Z10	●	10	5	80	10	17	27	14			
ASDM-CC06-D100x10-d32-Z12	●	12	6	100	10	25	32	14			
ASDM-CC06-D125x10-d40-Z14	●	14	7	125	10	35	40	14			
ASDM-CC06-D160x10-d40-Z16	●	16	8	160	10	52	40	14			
ASDM-CC06-D200x10-d40-Z18	●	18	9	200	10	70	40	14			
ASDM-CC09-D80x12-d27-Z08	●	8	4	80	12	17	27	16	CC.. 09T3.. ISO UCUNA UYGUNDUR. FOR ISO INSERT.	4015-M3.5x11	80-T15
ASDM-CC09-D100x12-d32-Z10	●	10	5	100	12	25	32	16			
ASDM-CC09-D125x12-d40-Z12	●	12	6	125	12	35	40	16			
ASDM-CC09-D160x12-d40-Z14	●	14	7	160	12	52	40	16			
ASDM-CC09-D200x12-d40-Z16	●	16	8	200	12	70	40	16			
ASDM-CC09-D80x14-d27-Z08	●	8	4	80	14	17	27	18			
ASDM-CC09-D100x14-d32-Z10	●	10	5	100	14	25	32	18			
ASDM-CC09-D125x14-d40-Z12	●	12	6	125	14	35	40	18			
ASDM-CC09-D160x14-d40-Z14	●	14	7	160	14	52	40	18			
ASDM-CC09-D200x14-d40-Z16	●	16	8	200	14	70	40	18			
ASDM-CC12-D80x16-d27-Z06	●	6	3	80	16	17	27	20	CC.. 1204.. ISO UCUNA UYGUNDUR. FOR ISO INSERT.	1020-M5x11	80-T20
ASDM-CC12-D100x16-d32-Z08	●	8	4	100	16	25	32	20			
ASDM-CC12-D125x16-d40-Z10	●	10	5	125	16	35	40	20			
ASDM-CC12-D160x16-d40-Z12	●	12	6	160	16	52	40	20			
ASDM-CC12-D200x16-d40-Z14	●	14	7	200	16	70	40	20			
ASDM-CC12-D80x18-d27-Z06	●	6	3	80	18	17	27	22			
ASDM-CC12-D100x18-d32-Z08	●	8	4	100	18	25	32	22			
ASDM-CC12-D125x18-d40-Z10	●	10	5	125	18	35	40	22			
ASDM-CC12-D160x18-d40-Z12	●	12	6	160	18	52	40	22			
ASDM-CC12-D200x18-d40-Z14	●	14	7	200	18	70	40	22			
ASDM-CC12-D250x18-d40-Z16	●	16	8	250	18	90	40	22			
ASDM-CC12-D80x20-d27-Z06	●	6	3	80	20	17	27	24			
ASDM-CC12-D100x20-d32-Z08	●	8	4	100	20	25	32	24			
ASDM-CC12-D125x20-d40-Z10	●	10	5	125	20	35	40	24			
ASDM-CC12-D160x20-d40-Z12	●	12	6	160	20	52	40	24			
ASDM-CC12-D200x20-d40-Z14	●	14	7	200	20	70	40	24			
ASDM-CC12-D250x20-d40-Z16	●	16	8	250	20	90	40	24			

R: Sağ/Right L: Sol/Left ● Stokta/In Stock ○ Stokta Yok/Non Stock Item

Sipariş Örneği/Ordering Example : 1 ad./pcs. ASDM-CC06-D80x8-d27-Z10
Kesme Hesabı : S 229 / Cutting Calculation : P 229



A TIP
A TYPE

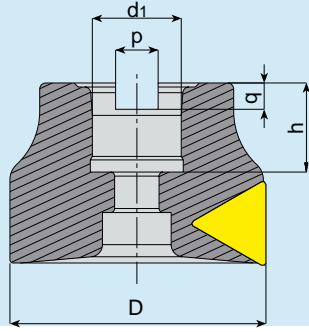

D	d1	d2	p	q	h
40	16	-	8.4	5.6	20
50	22	-	10.4	6.3	22
63	22	-	10.4	6.3	22
80	27	-	12.4	7	25
100	32	-	14.4	8	26

B TIP
B TYPE

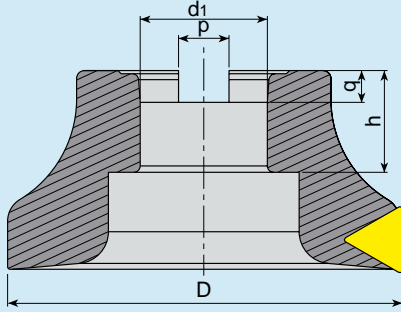

D	d1	d2	p	q	h
125	40	-	16.4	9	32

C TIP
C TYPE

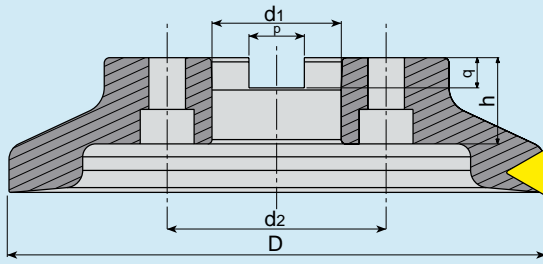

D	d1	d2	p	q	h
160	40	66.7	16.4	9	32
200	60	101.6	25.7	14	40
250	60	101.6	25.7	14	40

D TIP
D TYPE

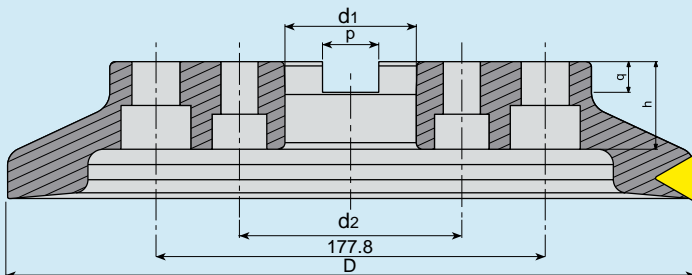

D	d1	d2	p	q	h
315	60	101.6	25.7	14	40

TAKMA UÇLU MATKAP (U-DRILL) KULLANMA KILAVUZU

Matkabınızı CNC torna tezgahına bağlamadan önce taretin merkezden kaçık olup olmadığını kontrol etmeniz gerekir. Şayet taretinizde kaçıklık varsa, takma uçlu matkabınızı kesinlikle kullanmayınız. Taretin düzeltilmesi için yapılması gereken işlemler ;

1. Taretin tutucusuna kullanacağınız takma uçlu matkabın çapında ve boyunda üzeri hassas olan silindirik bir parça bağlanır ve tezgahın X değeri sıfıra getirilir.
2. Tezgahın aynasına mıknatıslı komprotör saati yerleştirilir. Saatin uç kısmı tarete bağlanmış olduğumuz parçanın üstüne temas ettirilir.
3. Aynanın üzerine bağlanmış olduğumuz mıknatıslı komprotör ayna ile beraber 360 derece döndürülerek saatteki değişim oranına göre taretin sıfırlanması sağlanır.

TAKMA UÇLU MATKABINIZI CNC TORNANIZDA DAHA VERİMLİ KULLANMANIZ İÇİN GEREKLİ OLAN KESME HIZLARI ve DEVİRLERİ :

Grup No.	Malzemenin Cinsi	Malzemenin Öz.	Kesme Hızı Vc (m/dk)
1	Çok Yumuşak İş Çelikleri	C1010, Otomat vb.	220
2	İmalat Çelik ve Döküm Malz.	C1030 - 106 vb.	200
3	Takım ve İmalat Çeşitleri	CK-45, 4140, 7131 vb.	170
4	Sıcak İş ve Paslanmaz Çelikler	İmpaks vb.	150

Devir hesabı yapabilmek için önce malzemeyi seçiniz. Seçtiğiniz malzemenin kesme hızını (Vc) 1000 ile çarpıp 3.14'e bölmeliyiz. Çıkan değeri matkap çapına bölmeliyiz. **ÖRNEK** : Malzememiz takım ve imalat çeliği (3. grup), matkap çapı 25 mm kesme hızı 170 ise $170 \times 1000 = 170000 / 3.14 = 54140$, $54140 / 25 = 2166$ devir çıkar (Tezgahın İş Mili Devri). Tezgahın ilerlemesi kullanacağınız uç ile de alakalı olup 0.05 ile 0.10 arasında değişim gösterir. Kullanıcı kesici ucun kesişine göre bunu ayarlar.

İŞLEME MERKEZLERİ İÇİN İLERLEME HESABI :

Yukarıdaki hesaplamalarla bulmuş olduğunuz 2166 iş mili devrini, kesici uç ilerlemesi (mm/devir) 0.05 ile 0.10 arasındaki ilerleme seçenekleri ile çarpılır. **ÖRNEK 1** : $2166 \times 0.05 = 108$ **ÖRNEK 2** : $2166 \times 0.10 = 217$ çıkan sonuçlar 108 ve 217 işleme merkezleri için ilerleme mm/dakika hesabıdır.

USER'S GUIDE FOR AKKO U-DRILLS

Before connecting your U-Drill to CNC lathe, you have to check if the turret is eccentric from the center or not. If there is any eccentricity in your turret, never use your U-Drill;

Processes that should be done to fix the turret :

1. A cylindrical part whose surface is precision and whose length and diameter is the same with the U-Drill that you will use, should be mounted to the holder of turret and X value of the lathe should be brought to zero (0).
2. Comparator should be mounted to chuck. The end of the comparator should be contacted (touched) to the surface of the part that we mounted on the turret.
3. The comparator that we mounted on the chuck should be turned 360-degree with the chuck and turret should be zeroed by that turning according to changing rate of comparator.

CUTTING SPEED AND REVOLUTION THAT ARE NEEDED FOR USING (RUNNING) YOUR U-DRILLS MORE PRODUCTIVELY

Grup No.	Material	Material Type	Cutting Speed Vc (m/m)
1	Non-alloy steel and free cutting steel	C1010. Automat etc.	220
2	Low alloy steel and cast steel	C1030 - 106 etc.	200
3	Alloy steel and tool steel	CK-45, 4140, 7131 etc.	170
4	Hot Work Steel and Stainless Steel	Impax etc.	150

P.S. : The cutting speed may be concerned with the type of the insert that you use.

Fistly, choose the material to make calculation of revolution. You should multiply the cutting speed (Vc) of the material that you chose by 1000 and divide by 3.14. You should divide the value that you found by the diameter of U-Drill. For Example : If our material is alloy steel and tool steel (3rd group), diameter of the U-Drill is 25 mm, cutting speed is 170, we should calculate as following; $170 \times 1000 = 170000 / 3.14 = 54140$, $54140 / 25 = 2166$ rpm is the result that we found (Spindle Speed) Feed rate of the lathe is concerned with the U-Drill that you will use and changes between 0.05 and 0.10. The user sets it according to cut of cutting insert.

FEED CALCULATION FOR CENRAL MACHINE :

2166 spindle speed, that we found as a result of above mentioned calculation, should be multiplied by cutting insert feed (mm/r) between 0.05 and 0.10 feed choisses. Example 1 : $2166 \times 0.05 = 108$
Example 2 : $2166 \times 0.10 = 217$ The results 108 and 217 are the feed mm/m calculation for central machine.

FREZELEME İŞLEMİNDE DEVİR ve İLERLEME HESABI

Vc.	S	D	F	Z	fz	FORMÜLLER
Kesme Hızı (Uç Kutusunun Arkasından Okuyunuz)	İş Mili Devir Sayısı	Tarama Kafası Çapı	İlerleme	Tarama Kafası Ağız Sayısı	Diş Başına Düşen İlerleme Miktarı (Uç Kutusunun Arkasından Okuyunuz)	Devir Hesabı : $S=(Vc \times 1000) / (3,14 \times D)$ İlerleme Hesabı : $F=S \times Z \times fz$

Örnek : D=50 mm çapında, Z=5 ağızlı tarama kafası ile frezeleme yapacağız. Kesici uç kutusunun arkasında kesme hızı Vc=200m/dk. olarak verilmiş olsun. Tezgaha girilecek devri hesaplayalım: **Vc=200 m/dk. D=50 mm** S = Öncelikle Kesme Hızı 1000 ile çarpılır, çıkan sonuç 3,14 sayısına bölünür, buradan çıkan sonuç da tarama kafası çapına bölünür.

$S=200 \times 1000 = 200000 \rightarrow 200000/3,14=63663 \rightarrow 63663/50=1273$ devir **S=1273 dev/dakika** deviri bulduktan sonra ilerlemeyi bulalım : **Z=5** ağızlı tarama kafası olsun **fz=0,12** olarak uç kutusunun arkasından okunmuş olsun F= yukarıda bulmuş olduğumuz devir sayısı ile ağız sayısı çarpılır, çıkan sonuç diş başına düşen ilerleme miktarı ile çarpılır.

$F=1273 \times 5 = 6365 \rightarrow 6365 \times 0,12 = 763$ $F=763$ mm/dakika

Tezgaha girilecek olan devir = S 1273 Tezgaha girilecek olan ilerleme : **F 763 ortalama değerdir.**

Not: Vc ve fz değerlerinin uç kutusunun arkasında verilmiş olması gerekir. Eğer bu değerler uç kutusunun üzerinde yoksa, kesici ucun katalogundan bulunuz. İşleyeceğiniz malzeme çelik ise P, paslanmaz çelik ise M, dökme demir ise K bölümünde yazılı olan Vc ve fz değerlerini okuyun.

CALCULATING SPINDLE SPEED and FEED RATE FOR MILLING PROCESS

Vc.	S	D	F	Z	fz	FORMULAS
Cutting Speed (Please read from the back- side of cutting insert box)	Spindle Revolution rpm	Milling Tool Diameter	Feed Rate	Number of Effective Tooth	Feed Per Tooth (Please Read From The Back Side of Cutting Insert Box)	Calculation of Revolution : $S=(Vc \times 1000) / (3,14 \times D)$ Feed Rate Calculation : $F=S \times Z \times fz$

For Example : We will make milling with milling tool whose diameter is D 50 mm, whose teeth number is Z=5. The spindle revolution was written as Vc=200m/mn at the back side of cutting insert box. Let's calculate the revolution that should be entered to the milling machine : Vc=200 m/mn D=50 mm

S = Firstly Cutting Speed is multiplied with 1000, the result should be divided by 3.14 , the last result should be divided by diameter of milling tool.

$S = 200 \times 1000 = 200000 \rightarrow 200000/3,14 = 63663 \rightarrow 63663/50 = 1273$ rev $S=1273$ rev / mn

After finding spindle revolution, let's find feed rate : milling tool with Z=5 teeth and we read fz=0,12 from the back side of cutting insert box.

F = Tooth number should be multiplied with revolution, the result should be multiplied with feed per tooth.

$F = 1273 \times 5 = 6365 \rightarrow 6365 \times 0,12 = 763$ $F = 763$ mm / mn

Revolution that should be entered to the milling machine = S 1273 Feed Rate that should be entered to the milling machine = F 763 average value.

P.S : The values Vc and fz has to be written at the back side of the cutting insert. If these values were not written on the cutting insert box, please find them from cutting insert catalogue. If the material that you will work is steel, please read Vc and fz values that were written on the part P, if it is stainless steel please read from the part M, if it is cast iron please read from the part K.

ALTLIKLAR / SHIMS

ÜRÜN RESMİ/PICTURE	ÜRÜN KODU/CODE	ÜRÜN DETAYI / PRODUCT DETAIL	
	AATN-2-0001	S-SİSTEM için / For S-SYSTEM	TCMT 16 ALTLIK / SHIM
	AATN-2-0002	T-M SİSTEM için / For T-M SYSTEM C-SİSTEM için / For C-SYSTEM	TNMG 16 ALTLIK / SHIM TNGN 16 ALTLIK / SHIM
	AATN-3-0025	P-SİSTEM için / For P-SYSTEM	TNMG 16 ALTLIK / SHIM
	AATN-3-0015	T-M-P SİSTEM için / For T-M SYSTEM	TNMG 22 ALTLIK / SHIM
	AATN-2-0020	DİŞ VİDA 16 ALTLIK / For THREADING 16 SHIM	
	AATN-2-0004	DİŞ VİDA 22 ALTLIK / For THREADING 22 SHIM	
	ATS-16E	DİŞ VİDA 16, DİŞ ÇAP SAĞ - DELİK İÇİ SOL ALTLIK / For THREADING SYSTEM 16 SHIM, EXTERNAL RIGHT-INTERNAL LEFT	
	ATS-16I	DİŞ VİDA 16, DİŞ ÇAP SOL - DELİK İÇİ SAĞ ALTLIK / For THREADING SYSTEM 16 SHIM, EXTERNAL LEFT-INTERNAL RIGHT	
	ATS-22E	DİŞ VİDA 22, DİŞ ÇAP SAĞ - DELİK İÇİ SOL ALTLIK / For THREADING SYSTEM 22 SHIM, EXTERNAL RIGHT-INTERNAL LEFT	
	ATS-22I	DİŞ VİDA 22, DİŞ ÇAP SOL - DELİK İÇİ SAĞ ALTLIK / For THREADING SYSTEM 22 SHIM, EXTERNAL LEFT-INTERNAL RIGHT	
	ATS-27E	DİŞ VİDA 27, DİŞ ÇAP SAĞ - DELİK İÇİ SOL ALTLIK / For THREADING SYSTEM 27 SHIM, EXTERNAL RIGHT-INTERNAL LEFT	
	ATS-27I	DİŞ VİDA 27, DİŞ ÇAP SOL - DELİK İÇİ SAĞ ALTLIK / For THREADING SYSTEM 27 SHIM, EXTERNAL LEFT-INTERNAL RIGHT	
	AACN-2-0001	S-SİSTEM için / For S-SYSTEM	CCMT 09 ALTLIK / SHIM
		T-SİSTEM için / For T-SYSTEM	CNMG 09 ALTLIK / SHIM
	AACN-2-0002	P-SİSTEM için / For P-SYSTEM	CNMG 09 ALTLIK / SHIM
	AACN-2-0003	S-SİSTEM için / For S-SYSTEM	CCMT 12 ALTLIK / SHIM
		T-M-P SİSTEM için / For T-M-P SYSTEM	CNMG 12 ALTLIK / SHIM
	AACN-3-0001	C-SİSTEM için / For C-SYSTEM	CNGN 12 ALTLIK / SHIM
		T-P SİSTEM için / For T-P SYSTEM	CNMG 16 ALTLIK / SHIM
	AACN-3-0003	T-P SİSTEM için / For T-P SYSTEM	CNMG 19 ALTLIK / SHIM
AACN-3-0008	T-P SİSTEM için / For T-P SYSTEM	CNMG 25 ALTLIK / SHIM	
	AAWN-3-0001	T-M-P SİSTEM için / For T-M-P SYSTEM	WNMG 08 ALTLIK / SHIM
	AAWN-SW317	T-M-P SİSTEM için / For T-M-P SYSTEM	WNMG 06 ALTLIK / SHIM
	AKS-16L	C-SİSTEM için / For C-SYSTEM	KNUX-L 16 ALTLIK / SHIM
	AKS-16R	C-SİSTEM için / For C-SYSTEM	KNUX-R 16 ALTLIK / SHIM
	AASN-2-0001	S-SİSTEM için / For S-SYSTEM	SCMT 09 ALTLIK / SHIM
	AASN-2-0002	P-SİSTEM için / For P-SYSTEM	SNMG 09 ALTLIK / SHIM
	AASN-2-0004	S-SİSTEM için / For S-SYSTEM	SCMT 12 ALTLIK / SHIM
		T-P SİSTEM için / For T-P SYSTEM	SNMG 12 ALTLIK / SHIM
	AASN-3-0004	C-SİSTEM için / For C-SYSTEM	SNGN 12 ALTLIK / SHIM
		T-P SİSTEM için / For T-P SYSTEM	SNMG 15 ALTLIK / SHIM
	AASN-3-0023	T-P SİSTEM için / For T-P SYSTEM	SNMG 19 ALTLIK / SHIM
	AASN-3-0005	T-P SİSTEM için / For T-P SYSTEM	SNMG 19 ALTLIK / SHIM
	AASN-3-0020	T-P SİSTEM için / For T-P SYSTEM	SNMG 25 ALTLIK / SHIM
	AASN-20020	PSDNN KARTUŞ için / For PSDNN CARTRIDGE	
	AADN-2-0001	S-SİSTEM için / For S-SYSTEM	DCMT 11 ALTLIK / SHIM
		T-SİSTEM için / For T-SYSTEM	DNMG 11 ALTLIK / SHIM
	AADN-SD317	P-SİSTEM için / For P-SYSTEM	DNMG 11 ALTLIK / SHIM
	AADN-3-0001	T-M-P SİSTEM için / For T-M-P SYSTEM	DNMG 15 ALTLIK / SHIM
		C-SİSTEM için / For C-SYSTEM	DNGN 15 ALTLIK / SHIM
AADN-2-0003	T-SİSTEM için / For T-SYSTEM	DNMG 15 KALIN ALTLIK / THICK SHIM	
	AAVN-2-0002	S-SİSTEM için / For S-SYSTEM	VBMT 16, VCMT 16 ALTLIK / SHIM
		T-SİSTEM için / For T-SYSTEM	VNMG 16 ALTLIK / SHIM



BASKI PABUÇLARI / CLAMPS

ÜRÜN RESMİ/PICTURE	ÜRÜN KODU/CODE	ÜRÜN DETAYI / PRODUCT DETAIL
	ATK-01	T-SİSTEM için / For T-SYSTEM DNMG 11, WNMG 06, TNMG 16, CNMG 09 BASKI PABUCU / CLAMP
	ATK-02	T-SİSTEM için / For T-SYSTEM CNMG 12, WNMG 08, TNMG 22, DNMG 15, SNMG 12 BASKI PABUCU / CLAMP
	ATK-03	T-SİSTEM için / For T-SYSTEM VNMG 16 BASKI PABUCU / CLAMP
	ATK-04	T-SİSTEM için / For T-SYSTEM CNMG 16, SNMG 15 BASKI PABUCU / CLAMP
	AMK-01	M-SİSTEM için / For M-SYSTEM WNMG 06 BASKI PABUCU / CLAMP
	AMK-02	M-SİSTEM için / For M-SYSTEM DELİK İÇİ / INTERNAL Ø20 TNMG 16 Ø25 MT-NR/L 16 BASKI PABUCU / CLAMP
	AMK-03	M-SİSTEM için / For M-SYSTEM DNMG 11, CNMG 12 BASKI PABUCU / CLAMP
	AMK-04	M-SİSTEM için / For M-SYSTEM DNMG 15, TNMG 16-22 BASKI PABUCU / CLAMP
	AMK-05	M-SİSTEM için / For M-SYSTEM WNMG 08 BASKI PABUCU / CLAMP
	AMK-07	M-SİSTEM için / For M-SYSTEM S20R MCLNR/L BASKI PABUCU / CLAMP
	ACK-01-R	C-SİSTEM için / For C-SYSTEM KNUX-R BASKI PABUCU / CLAMP
	ACK-02-L	C-SİSTEM için / For C-SYSTEM KNUX-L BASKI PABUCU / CLAMP
	ACK-03	C-SİSTEM için / For C-SYSTEM 154.91 DIŞ ÇAP ve DELİK İÇİ / EXTERNAL and INTERNAL Ø25-Ø32 BASKI PABUCU / CLAMP
	ACK-04	P-C SİSTEM için / For P-C SYSTEM CTFPR KARTUŞ BASKI PABUCU / CARTRIDGE CLAMP
	ACK-05	P-C SİSTEM için / For P-C SYSTEM FREZELEME ve DIŞ VİDA AÇMA TAKIMLARINA GÖRE İLAVE BASKI PABUCU ADDITIONAL LITTLE CLAMP for MILLING and THREADING CLAMP
	ACK-06	C-SİSTEM için / For C-SYSTEM 154.91 DELİK İÇİ / INTERNAL Ø16-Ø20 BASKI PABUCU / CLAMP
	ACK-07	C-SİSTEM için / For C-SYSTEM SERAMİK CNGN, SNGN, DNGN YEDEK TAKIMI SPARE PART SET of CERAMIC CNGN, SNGN, DNGN
	ACK-08	C-SİSTEM için / For C-SYSTEM SERAMİK TNGN, YEDEK TAKIMI SPARE PART SET of CERAMIC TNGN
	ACK-09	P-SİSTEM için / For P-SYSTEM CNMG 16-19, SNMG 15-19 İLAVE BÜYÜK BASKI PABUCU ADDITIONAL BIG CLAMP
	ACK-10	C-SİSTEM FREZELEME için For C-SYSTEM MILLING SPKN 12 ve Ø50-Ø63 TPKN 16 BASKI PABUCU / CLAMP (M8x8)
	ACK-11	C-SİSTEM FREZELEME için For C-SYSTEM MILLING Ø80-Ø100 TPKN 16-TPKN 22, OFKR 07, HNMX 09 BASKI PABUCU / CLAMP (M8x10)
	ACK-12	C-SİSTEM için For C-SYSTEM CTSPR KARTUŞ BASKI PABUCU / CARTRIDGE CLAMP
	ACK-15	S-SİSTEM FREZELEME için For S-SYSTEM MILLING RD.. 10-12 BASKI PABUCU / CLAMP
	ACK-19	S-SİSTEM FREZELEME için For S-SYSTEM MILLING WD0805D BASKI PABUCU / CLAMP
	ACK-23	C-SİSTEM için / For C-SYSTEM SERAMİK DNGN 11, YEDEK TAKIMI SPARE PART SET of CERAMIC DNGN 11

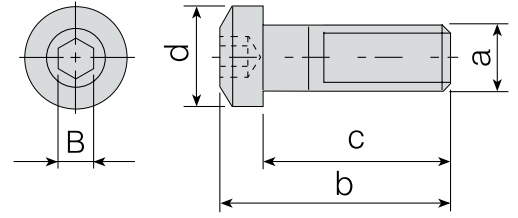

BASKI PABUÇ VİDALARI / CLAMP SCREWS

Takım Kodu Ordering Code	a (M)	b	c	d	B	Ürün Detayı Product Detail
AKV-01-M5X22	M5x0.8	25.1	22	11	3	T-SİSTEM için / For T- SYSTEM DNMG 11, WNMG 06, TNMG 16
AKV-02-M6X22	M6x1.0	25.3	22	11	3	T-SİSTEM için / For T- SYSTEM CNMG 12, WNMG 08, TNMG 22, DNMG 15, SNMG 12, VNMG 16
						M-SİSTEM için / For M- SYSTEM TNMG 16, TNMG 22
						KANAL KATERİ için / For EXTERNAL GROOVING 2mm Dış Çap Kanal Kater Vidası / External Grooving Tools Screw
AKV-03-M6X22	M6x1.0	25.3	22	10	3	M-SİSTEM için / For M- SYSTEM WNMG 08
AKV-04-M5X17	M5x0.8	20	17	8.5	3	M-SİSTEM için / For M- SYSTEM S20R MT-NR/L 16, S20R-S25S MWLNR/L 06, S25S MDUNR/L 11-Dış Çap / External MWLNR 06
AKV-05-M6X25	M6x1.0	29.5	25	13.8	4	T-SİSTEM için / For T- SYSTEM Eski Ürün Vidası / Old Products Screws CNMG 16, SNMG 15
AKV-06-M6X20	M6x1.0	26.5	20	10.6	4	C-SİSTEM için / For C-SYSTEM KNUX 16
AKV-07-M6X22	M6x1.0	23.5	22	8.5	3	C-SİSTEM için / For C-SYSTEM ADKT-154.91, AIKT-154.91-R/L-32
AKV-10-M6X14	M6x1.0	16	14	8.8	4	C-SİSTEM için / For C-SYSTEM AIKT-154.91-R/L-16, AIKT-154.91-R/L-20, AIKT-154.91-R/L-25
AKV-11-M8X29	M8x1.25	33.6	29	11	4	C-SİSTEM için / For C-SYSTEM TNGN 16, CNGN 12, DNGN 15, SNGN 12
AKV-17-M5X15	M5x0.8	18	15	8.55	3	M-SİSTEM için / For M- SYSTEM S16P MWLNR/L 06
AKV-19-M7X25	M7x1.0	29.6	25	14	4	T-SİSTEM için / For T- SYSTEM Yeni / New CNMG 16, SNMG 15
AKV-20-M6X19	M6x1.0	22	19	11	3	M-SİSTEM için / For M- SYSTEM S25S MDUNR/L 15
AKV-21-M6X18	M6x1.0	20	18	8.5	3	C-SİSTEM için / For C-SYSTEM AIKT-154.91-R/L-25
AKV-23-M4X10	M4x0.7	12.2	10	7.4	2.5	KARTUŞ için / For CARTRIDGE MONTAJ VİDASI / MOUNTING SCREW

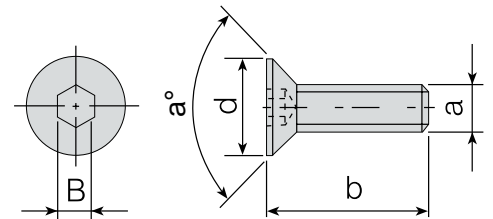

ALTLIK VİDALARI / SHIM SCREWS

Takım Kodu Ordering Code	a (M)	b	d	B	a°	Ürün Detayı Product Detail
AAV-01-M3x10	M3x0.5	10	5.9	2	90°	T-SİSTEM için / For T-SYSTEM WNMG 06, KNUX 16
AAV-02-M5X12	M5x0.8	12	7	3	56°	T-SİSTEM için / For T-SYSTEM CNMG 12, WNMG 08, TNMG 22, DNMG 15, SNMG 12
AAV-05-M6X15	M6x1.0	16	9	4	60°	T-SİSTEM için / For T-SYSTEM CNMG 16, SNMG 15
AKV-12-M5X12	M5x0.8	12	7.8	3	90°	C-SİSTEM için / For C-SYSTEM CTSPR Baskı Pabuç Vidası / Clamp Screw
AKV-16-M6X16	M6x1.0	16	10	4	76°	C-SİSTEM için / For C-SYSTEM CTFPR 13CS 16 Baskı Pabuç Vidası / Clamp Screw
AAV-13-M5X8	M5x0.8	8	7	3	56°	T-SİSTEM için / For T-SYSTEM S25S TSKNR/L 12, S25S TCLNR/L 12, S25S TWLNR/L 08, S25S TDUNR/L 15

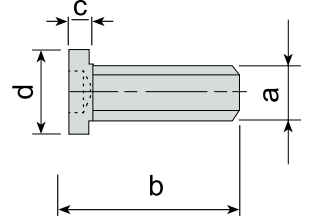
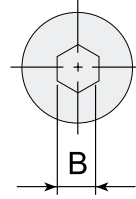

ALTLIK VİDALARI / SHIM SCREWS

Takım Kodu Ordering Code	a (M)	b	c	d	B	Ürün Detayı Product Detail	
						T-SİSTEM için / For T-SYSTEM	C-SİSTEM için / For C-SYSTEM
AAV-03-M5X12	M5X0.8	12	1.4	6	3	T-SİSTEM için / For T-SYSTEM	TNMG 16
						C-SİSTEM için / For C-SYSTEM	TNGN 16
AAV-04-M5X12	M5X0.8	12	1.2	6.5	3	T-SİSTEM için / For T-SYSTEM	VNMG 16, DNMG 11, CNMG 09
AAV-09-M5X9	M5X0.8	9	1.4	6	3	T-SİSTEM için / For T-SYSTEM	S25S TCLNR/L 09, S25S TDUNR/L 11, S25S TDQNR/L 11

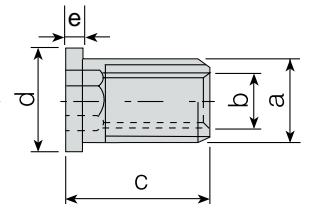
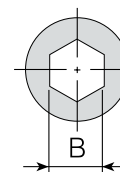
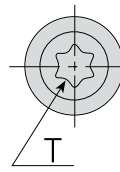

BUKSE VİDALAR / BUKSE SCREWS

Takım Kodu Ordering Code	a (M)	b	c	d	B(T)	e	Ürün Detayı Product Detail	
							S-SİSTEM için / For S- SYSTEM	S-SİSTEM için / For S- SYSTEM
AAV-06-M3.5X11	M5x0.5	M3.5x0.6	11.3	6	20	1.2	S-SİSTEM için / For S- SYSTEM	CCMT 09, DCMT 11, VBMT 16, VCMT 16, TCMT 16, SCMT 09, 16 ER/L, 16 IR/L
AAV-07-M4.5X11	M6X0.75	M4.5X0.75	12	7.5	4.5	1.6	S-SİSTEM için / For S- SYSTEM	CCMT 12, SCMT 12, 22 ER/L, 22 IR/L
AAV-08-M3.5X8	M5X0.5	M3.5x0.6	8	6	20	1.2	S-SİSTEM için / For S- SYSTEM	Ø25 DCMT 11, Ø25-Ø32 CCMT 09, Ø25 TCMT 16, S25S-S32T SVJBR/L 16,
AAV-10-M4.5X8	M6X0.75	M4.5X0.75	8	7.5	4.5	1.05	S-SİSTEM için / For S- SYSTEM	Ø25-Ø32 CCMT 12, Ø25-Ø32 SCMT 12, SSDCN 1616 H12, SSSCR/L 1616 H12, SIR/L S25R 22

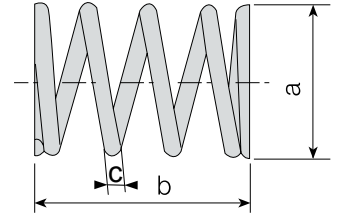
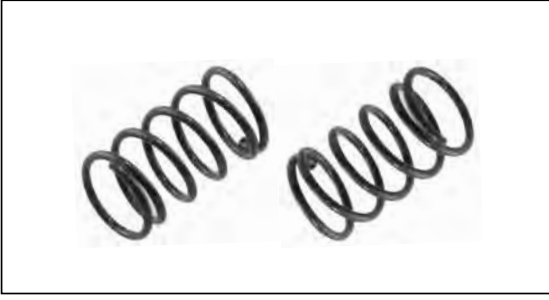

BASKI YAYI / CLAMP SPRING

Takım Kodu Ordering Code	a	b	c	Ürün Detayı Product Detail	
AKY-01	7.7	11.2	0.9	T-SİSTEM için / For T-SYSTEM	CNMG 12, WNMG 08, TNMG 22, DNMG 15, SNMG 12, VNMG 16
AKY-02	8.5	13.5	0.7	C-SİSTEM için / For C-SYSTEM	KNUX 16

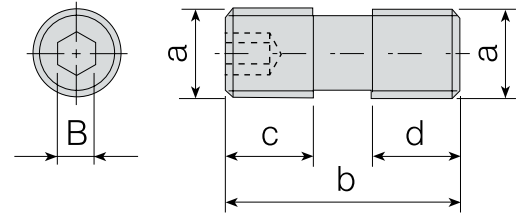

BASKI PABUÇ VİDALARI / CLAMP SCREWS

Takım Kodu Ordering Code	a (M)	b	c	d	B	Ürün Detayı Product Detail	
AKV-13-M8X1X16	M8x1.0	16	6.8	6.8	4	C-SİSTEM FREZELEME için / MILLING For C-SYSTEM	SPKN 12 ve Ø63 TPKN 16
AKV-14-M-8X1X18	M8x1.0	18	8	8	4	C-SİSTEM FREZELEME için / MILLING For C-SYSTEM	Ø80-Ø100 TPKN 16 ve Ø63-Ø315 TPKN 22
AKV-15-M8X1X20	M8x1.0	20	8.5	8.5	4	C-SİSTEM FREZELEME için / MILLING For C-SYSTEM	OFKR 07, HNMX 09
AKV-18-M5X14	M5x0.8	15	5	6.8	2.5	C-SİSTEM FREZELEME için / MILLING For C-SYSTEM	SN19
AKV-22-M8X1X14	M8x1.0	14	6.8	4.8	4	C-SİSTEM FREZELEME için / MILLING For C-SYSTEM	Ø50 TPKN 16

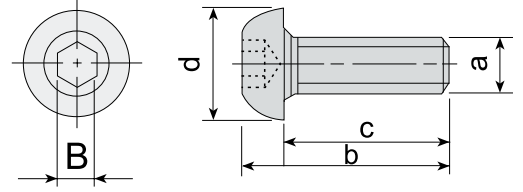

KANAL KATER ve MANTAR VİDALAR / GROOVING TOOL and CLAMP SCREWS

Takım Kodu Ordering Code	a (M)	b	c	d	B	Ürün Detayı Product Detail
1904-M8X1X20	M8X1.0	25.9	20	11.3	4	S-SİSTEM için / For S- SYSTEM RCMT 32 Sıkma Vidası / Clamp Screw
2004-M8X1X20	M8X1.0	25.9	20	11.4	4	KANAL KATERİ için / For EXTERNAL GROOVING Kanal Kater Vidası / External Grooving Tools Screw
2004-M8X20	M8X1.25	30	25	25	4	KANAL KATERİ için / For EXTERNAL GROOVING Eski Kanal Kater Vidası / Old External Grooving Tools Screw
AKV-08-M6X12	M6x1.0	17	12	14.3	4	C-SİSTEM FREZELEME için / MILLING For C- SYSTEM Baskı ve Sıkma Vidası, Mantar Vida / Clamp Screw
AKV-09-M8X18	M8X1.0	24	18	17.2	5	C-SİSTEM FREZELEME için / MILLING For C- SYSTEM Baskı ve Sıkma Vidası, Mantar Vida / Clamp Screw

LEVYELER / LEVERS

Ürün Resmi Product Picture	Ürün Kodu Product Code	Ürün Detayı Product Detail
	APL-01	P-SİSTEM için / For P-SYSTEM CNMG 09, DNMG 11, SNMG 09, TNMG 16, WNMG 06 LEVYESİ / LEVER
	APL-02	P-SİSTEM için / For P-SYSTEM CNMG 12, SNMG 12, TNMG 22, WNMG 08 LEVYESİ / LEVER
	APL-03	P-SİSTEM için / For P-SYSTEM DNMG 15 LEVYESİ / LEVER
	APL-04	P-SİSTEM için / For P-SYSTEM CNMG 16, SNMG 15 LEVYESİ / LEVER
	APL-05	P-SİSTEM için / For P-SYSTEM CNMG 19, SNMG 19 LEVYESİ / LEVER
	APL-06	P-SİSTEM için / For P-SYSTEM CNMG 25, SNMG 25 LEVYESİ / LEVER
	APL-07	P-SİSTEM için / For P-SYSTEM S16P PCLNR/L 09, S16P PTUNR/L 16 LEVYESİ / LEVER

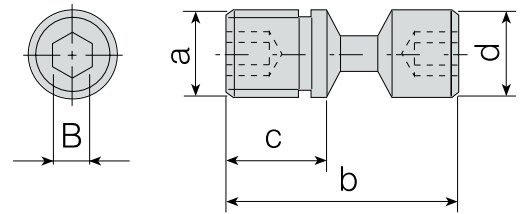

LEVYE VİDALARI / LEVER SCREWS

Takım Kodu Ordering Code	a (M)	b	c	d	B	Ürün Detayı Product Detail
ALV-01-M6X14	M6x1.0	14	10	5.85	2.5	P-SİSTEM için / For P-SYSTEM S20R PCLNR/L 09, S20R PDUNR/L 11, S20R PDQNR/L 11, S20R PWLNR/L 06, S20R PTUNR/L 16
ALV-02-M6X17	M6x1.0	17	10	5.85	2.5	P-SİSTEM için / For P-SYSTEM CNMG 09, DNMG 11, SNMG 09, TNMG 16, WNMG 06
ALV-03-M8X19	M8X1.0	19.8	11	7.9	3	P-SİSTEM için / For P-SYSTEM CNMG 12, SNMG 12, TNMG 22, WNMG 08, DNMG 15
ALV-04-M8X22	M8X1.0	21.5	13	7.75	3	P-SİSTEM için / For P-SYSTEM CNMG 16, SNMG 15
ALV-05-M10X27	M10X1.0	27.5	15	9.9	4	P-SİSTEM için / For P-SYSTEM CNMG 19, SNMG 19
ALV-06-M12X36	M12X1.0	36	20	12	5	P-SİSTEM için / For P-SYSTEM CNMG 25, SNMG 25
ALV-07-M6X13	M6X0.1	12.6	6.5	5.9	2.5	P-SİSTEM için / For P-SYSTEM S16P PCLNR/L 09, S16P PCTUR/L 16
ALV-08-M8X16	M8X1.0	16	10	7.9	3	P-SİSTEM için / For P-SYSTEM S25S PCLNR/L 12, S25S PDUNR/L 15, S25S PSKNR/L 12

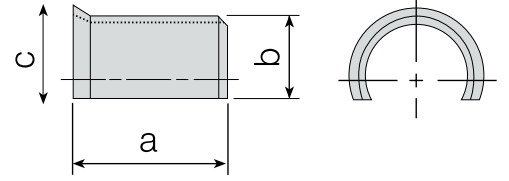

ALTLIK YAYLARI / SHIM SPRINGS

Takım Kodu Ordering Code	Ürün Detayı Product Detail				
	a	b	c		
AAV-01	5.6	4.9	6	P-SİSTEM için / For P-SYSTEM CNMG 09 ,DNMG 11, SNMG 09, TNMG 16, WNMG 06	
AAV-02	6	6.9	7.9	P-SİSTEM için / For P-SYSTEM CNMG 12, SNMG 12, TNMG 22, WNMG 08, DNMG 15	
AAV-03	8.9	8	9.5	P-SİSTEM için / For P-SYSTEM CNMG 16, SNMG 15	
AAV-04	11	9.8	10.7	P-SİSTEM için / For P-SYSTEM CNMG 19, SNMG 19	
AAV-05	12	13	15	P-SİSTEM için / For P-SYSTEM CNMG 25, SNMG 25	

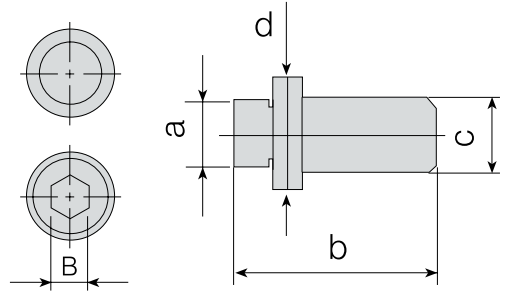

PİMLER / PINS

Takım Kodu Ordering Code	Ürün Detayı Product Detail					
	a	b	c	d	B	
APM-01	3.55	18	5	6	-	M-SİSTEM için / For M- SYSTEM DELİK İÇİ / INTERNAL Ø32-Ø40 TNMG 16 - DIŞ ÇAP / EXTERNAL TNMG 16
APM-02	5	18	6	7.3	-	M-SİSTEM için / For M- SYSTEM TNMG 22, WNMG 08
APM-03	3.5	12	5	6.5	-	M-SİSTEM için / For M- SYSTEM S20R MTFNR/L 16, S20R MT-NR/L 16, S20R MTUNR/L 16, S20R MTQNR/L 16, S20R MDUNR/L 11
APM-04	5	15	6	7.3	-	M-SİSTEM için / For M- SYSTEM S32T MCLNR/L 12, DNMG 15, S25S MWLNR/L 08
APM-05	5	11.5	6.5	6.5	3	M-SİSTEM için / For M- SYSTEM MSYNR 11.5CS 12 KARTUŞ için / for MSYNR 11.5CS 12 CARTRIDGE
APM-06	3	15.7	-	-	-	C-SİSTEM için / For C- SYSTEM 154.91
APM-07	3.5	11.5	6.5	6.5	3	M-SİSTEM için / For M- SYSTEM S20R ET-NR 16
APM-08	3.5	12	5	5.4	-	M-SİSTEM için / For M- SYSTEM S25S MWLNR/L 06, Diş Çap / External MWLNR 06
APM-09	3.5	10	5	5.4	-	M-SİSTEM için / For M- SYSTEM S16P MWLNR/L 06
APM-10	3.5	11	5	5.4	-	M-SİSTEM için / For M- SYSTEM S20R MWLNR/L 06
APM-11	3.5	11	5	6.5	-	M-SİSTEM için / For M- SYSTEM S20R MTQNR/L 16
APM-12	5	12	6	7.3	-	M-SİSTEM için / For M- SYSTEM S20R MCLNR/L 12, S25S MCLNR/L 12-Z
APM-13	5	14	6	7.3	-	M-SİSTEM için / For M- SYSTEM S25S MCLNR/L 12
APM-14	3.55	15	5	6	-	M-SİSTEM için / For M- SYSTEM S25S MTFNR/L 16, S25S MT-NR/L 16, S25S MTUNR/L 16, S25S MTQNR/L 16
APM-15	4.40	16	6.40	6.40	3	M-SİSTEM için / For M- SYSTEM MSYNR 16CS 12 KARTUŞ için / for MSYNR 16CS 12 CARTRIDGE

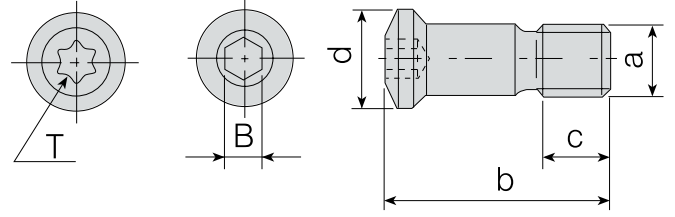

KÜRESEL FİNİŞ VİDALARI / BALL NOSE SCREWS

Takım Kodu Ordering Code	a (M)	b	c	d	B(T)	Ürün Detayı Product Detail	
1208-M3x7	M3x0.5	6.9	2.7	4.1	8	KÜRESEL FREZE VİDASI / BALL NOSE SCREW	P3208
1215-M4X0.5X9	M4X0.5	8.6	3.2	5.75	15	KÜRESEL FREZE VİDASI / BALL NOSE SCREW	P3210-ROHX 12
1220-M5X0.5X9	M5X0.5	9.6	3.4	6.8	20	KÜRESEL FREZE VİDASI / BALL NOSE SCREW	P3212
1220-M5X0.5X12	M5X0.5	12.9	4.4	7.4	20	KÜRESEL FREZE VİDASI / BALL NOSE SCREW	P3216-ROHX 16
1220-M5X0.5X15	M5X0.5	16.4	6	7.8	20	KÜRESEL FREZE VİDASI / BALL NOSE SCREW	P3220-ROHX 20
1220-M6X0.75X20	M6X0.75	20	6	9.4	20	KÜRESEL FREZE VİDASI / BALL NOSE SCREW	P3225
1204-M8X0.75X26	M8X0.75	26	7.5	12	4	KÜRESEL FREZE VİDASI / BALL NOSE SCREW	P3232

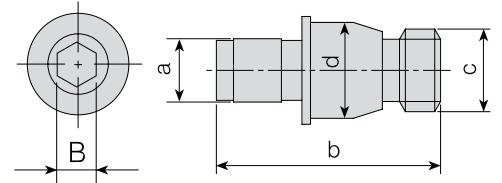

EKSANTRİK VİDA / ECCENTRIC SCREW

Takım Kodu Ordering Code	a	b	c	d	B	Ürün Detayı Product Detail	
AEV-01-M6x16	4.85	16	M6x1.0	6.5	2.5	EKSANTRİK VİDA / ECCENTRIC SCREW	PSDNN KARTUŞ için / for PSDNN CARTRIDGE

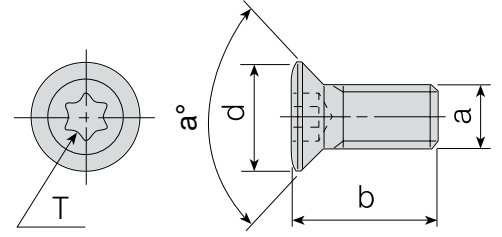

TORK VİDALARI / TORX SCREWS

Takım Kodu Ordering Code	Ürün Detayı Product Detail						
	a (M)	b	T	d	a°		
3006-M1.6X3.2	M1.6X0.35	3.2	6	2.50	60	S-SİSTEM için / For S-SYSTEM	TORK VİDA / TORX SCREW
3006-M1.8X4	M1.8X0.35	4	6	2.45	60	S-SİSTEM için / For S-SYSTEM	TORK VİDA / TORX SCREW
3006-M2X4	M2X0.4	4.3	6	2.7	60	S-SİSTEM için / For S-SYSTEM	TORK VİDA / TORX SCREW
4006-M2X5	M2X0.4	5	6	3	55	S-SİSTEM için / For S-SYSTEM	TORK VİDA / TORX SCREW
4006-M2.2X5	M2.2X0.45	5	6	2.8	55	S-SİSTEM için / For S-SYSTEM	TORK VİDA / TORX SCREW
3007-M2.2X5	M2.2X0.45	5.2	7	3.15	60	S-SİSTEM için / For S-SYSTEM	TORK VİDA / TORX SCREW
1008-M2.5X5	M2.5X0.45	5.5	8	3.5	45	S-SİSTEM için / For S-SYSTEM	TORK VİDA / TORX SCREW
1008-M2.5X7	M2.5X0.45	7	8	3.6	45	S-SİSTEM için / For S-SYSTEM	TORK VİDA / TORX SCREW
1108-M2.5x6	M2.5X0.45	6.5	8	3.9	R	S-SİSTEM için / For S-SYSTEM	TORK VİDA / TORX SCREW
3008-M2.5X5	M2.5X0.45	5	8	3.5	60	S-SİSTEM için / For S-SYSTEM	TORK VİDA / TORX SCREW
3008-M2.5X6	M2.5X0.45	6	8	3.5	60	S-SİSTEM için / For S-SYSTEM	TORK VİDA / TORX SCREW
4008-M2.5X4	M2.5X0.45	4	8	3.5	45	S-SİSTEM için / For S-SYSTEM	TORK VİDA / TORX SCREW
4008-M2.5X4.5	M2.5X0.45	4.5	8	3.5	45	S-SİSTEM için / For S-SYSTEM	TORK VİDA / TORX SCREW
4008-M2.5X6	M2.5X0.45	5.8	8	3.5	45	S-SİSTEM için / For S-SYSTEM	TORK VİDA / TORX SCREW
1008-M3X6	M3X0.5	6	8	4	45	S-SİSTEM için / For S-SYSTEM	TORK VİDA / TORX SCREW
1008-M3X8	M3X0.5	8	8	3.9	45	S-SİSTEM için / For S-SYSTEM	TORK VİDA / TORX SCREW
3008-M3X7	M3X0.5	7	8	4	55	S-SİSTEM için / For S-SYSTEM	TORK VİDA / TORX SCREW
4008-M3X8	M3X0.5	8	8	4	60	S-SİSTEM için / For S-SYSTEM	TORK VİDA / TORX SCREW
4010-M3X6	M3X0.5	6	10	4.2	45	S-SİSTEM için / For S-SYSTEM	TORK VİDA / TORX SCREW
4010-M3X8	M3X0.5	8	10	4.2	45	S-SİSTEM için / For S-SYSTEM	TORK VİDA / TORX SCREW
1015-M3.5X11	M3.5X0.6	11.1	15	5.3	60	S-SİSTEM için / For S-SYSTEM	TORK VİDA / TORX SCREW
1015-M3.5X14	M3.5X0.6	14	15	5.3	45	S-SİSTEM için / For S-SYSTEM	TORK VİDA / TORX SCREW
1015-M3.5X16	M3.5X0.6	16	15	5.3	55	S-SİSTEM için / For S-SYSTEM	TORK VİDA / TORX SCREW
1015-M3.5X9	M3.5X0.6	9	15	5.3	60	S-SİSTEM için / For S-SYSTEM	TORK VİDA / TORX SCREW
1315-M3.5X11	M3.5X0.6	10.6	15	7.9	-	S-SİSTEM için / For S-SYSTEM	TORK VİDA / TORX SCREW
1410-M3.5X9	M3.5X0.6	8.2	10	4.75	R	S-SİSTEM için / For S-SYSTEM	TORK VİDA / TORX SCREW
1510-M3.5X7	M3.5X0.6	7.1	10	5.1	55	S-SİSTEM için / For S-SYSTEM	TORK VİDA / TORX SCREW
1510-M3.5X9	M3.5X0.6	9.1	10	5	55	S-SİSTEM için / For S-SYSTEM	TORK VİDA / TORX SCREW
1615-M3.5X10	M3.5X0.6	10	15	5.8	60	S-SİSTEM için / For S-SYSTEM	TORK VİDA / TORX SCREW
1615-M3.5X11	M3.5X0.6	11	15	5.8	60	S-SİSTEM için / For S-SYSTEM	TORK VİDA / TORX SCREW
1615-M3.5X15	M3.5X0.6	15	15	5.8	60	S-SİSTEM için / For S-SYSTEM	TORK VİDA / TORX SCREW
3015-M3.5X9	M3.5X0.6	8.8	15	5.4	60	S-SİSTEM için / For S-SYSTEM	TORK VİDA / TORX SCREW
4015-M3.5X10	M3.5X0.6	9.8	15	5.3	60	S-SİSTEM için / For S-SYSTEM	TORK VİDA / TORX SCREW
4015-M3.5X11	M3.5X0.6	10.7	15	5.3	60	S-SİSTEM için / For S-SYSTEM	TORK VİDA / TORX SCREW
4015-M3.5X12	M3.5X0.6	12	15	5.3	60	S-SİSTEM için / For S-SYSTEM	TORK VİDA / TORX SCREW
4015-M3.5X14	M3.5X0.6	13.7	15	5.3	60	S-SİSTEM için / For S-SYSTEM	TORK VİDA / TORX SCREW
4015-M3.5X8	M3.5X0.6	7.9	15	5.3	55	S-SİSTEM için / For S-SYSTEM	TORK VİDA / TORX SCREW
4015-M3.5X9	M3.5X0.6	8.7	15	5.3	60	S-SİSTEM için / For S-SYSTEM	TORK VİDA / TORX SCREW

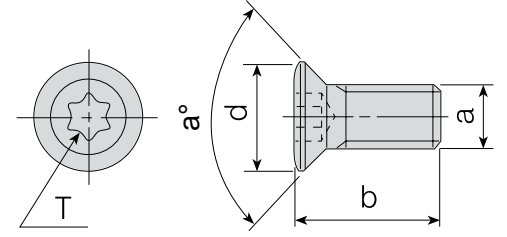

TORK VİDALARI / TORX SCREWS

Takım Kodu Ordering Code	TORK VİDALARI / TORX SCREWS						Ürün Detayı Product Detail	TORK VİDA / TORX SCREW
	a (M)	b	T	d	a°			
1015-M4X9	M4X0.7	,9	15	6.8	R	S-SİSTEM için / For S-SYSTEM	TORK VİDA / TORX SCREW	
1015-M4X11	M4X0.7	10.8	15	6.8	R	S-SİSTEM için / For S-SYSTEM	TORK VİDA / TORX SCREW	
1115-M4x10	M4X0.7	10	15	5.9	R	S-SİSTEM için / For S-SYSTEM	TORK VİDA / TORX SCREW	
1315-M4X11	M4X0.7	11.1	15	5	45	S-SİSTEM için / For S-SYSTEM	TORK VİDA / TORX SCREW	
1415-M4X11	M4X0.7	11	15	5.6	50	S-SİSTEM için / For S-SYSTEM	TORK VİDA / TORX SCREW	
1515-M4X11	M4X0.7	11.1	15	5.6	55	S-SİSTEM için / For S-SYSTEM	TORK VİDA / TORX SCREW	
1515-M4X9	M4X0.7	9	15	5.7	55	S-SİSTEM için / For S-SYSTEM	TORK VİDA / TORX SCREW	
1615-M4X11	M4X0.7	11.1	15	6	50	S-SİSTEM için / For S-SYSTEM	TORK VİDA / TORX SCREW	
4015-M4X12	M4X0.7	12	15	5.7	50	S-SİSTEM için / For S-SYSTEM	TORK VİDA / TORX SCREW	
1015-M4.5X12	M4.5X0.75	12	15	6.6	50	S-SİSTEM için / For S-SYSTEM	TORK VİDA / TORX SCREW	
1020-M4.5X16	M4.5X0.75	16	20	6.5	45	S-SİSTEM için / For S-SYSTEM	TORK VİDA / TORX SCREW	
1120-M4.5X12	M4.5X0.75	12.1	20	7.9	R	S-SİSTEM için / For S-SYSTEM	TORK VİDA / TORX SCREW	
1515-M4.5X11	M4.5X0.75	11	15	6.4	45	S-SİSTEM için / For S-SYSTEM	TORK VİDA / TORX SCREW	
4020-M4.5X10	M4.5X0.75	10	20	6.6	60	S-SİSTEM için / For S-SYSTEM	TORK VİDA / TORX SCREW	
4020-M4.5X12	M4.5X0.75	12	20	6.6	60	S-SİSTEM için / For S-SYSTEM	TORK VİDA / TORX SCREW	
1020-M5X11	M5X0.8	11	20	6.6	50	S-SİSTEM için / For S-SYSTEM	TORK VİDA / TORX SCREW	
1020-M5X14	M5X0.8	14.1	20	6.8	50	S-SİSTEM için / For S-SYSTEM	TORK VİDA / TORX SCREW	
1615-M5x14	M5X0.8	14	15	7.3	50	S-SİSTEM için / For S-SYSTEM	TORK VİDA / TORX SCREW	
1620-M5x18	M5X0.8	18	20	8.15	50	S-SİSTEM için / For S-SYSTEM	TORK VİDA / TORX SCREW	
1620-M5x22	M5X0.8	22	20	8.15	50	S-SİSTEM için / For S-SYSTEM	TORK VİDA / TORX SCREW	
1020-M6X16	M6X1.0	16	20	8.5	50	S-SİSTEM için / For S-SYSTEM	TORK VİDA / TORX SCREW	
1420-M6X16	M6X1.0	16	20	7.6	50	S-SİSTEM için / For S-SYSTEM	TORK VİDA / TORX SCREW	
1520-M6X16	M6X1.0	16	20	8.2	50	S-SİSTEM için / For S-SYSTEM	TORK VİDA / TORX SCREW	
1710-U5-40X12.2	UNC 5-40	12.2	10	5.6	60	S-SİSTEM için / For S-SYSTEM	TORK VİDA / TORX SCREW	
1720-U8-32X15	UNC 8-32	15	20	7.5	60	S-SİSTEM için / For S-SYSTEM	TORK VİDA / TORX SCREW	

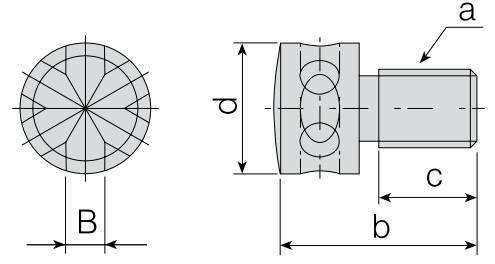

EKSENEL AYAR VİDALARI / AXIAL ADJUSTING SCREWS

Takım Kodu Ordering Code	EKSENEL AYAR VİDALARI / AXIAL ADJUSTING SCREWS					Ürün Detayı Product Detail
	a (M)	b	c	d	B	
2600-M4x9.5	M4x0.5	5.5	4	4	1.5	KARTUŞ için / for CARTRIDGE
2600-M5x13	M5x0.5	12.8	7	8.7	2.5	KARTUŞ için / for CARTRIDGE
2600-M6x18	M6x1.0	18.2	9	10	3.5	KARTUŞ için / for CARTRIDGE

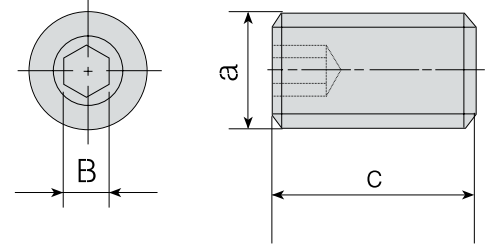

RADYAL AYAR VİDALARI / RADIAL ADJUSTING SCREWS

Takım Kodu Ordering Code	RADYAL AYAR VİDALARI / RADIAL ADJUSTING SCREWS			Ürün Detayı Product Detail
	a (M)	c	B	
2715-M3x4	M3x0.5	4	1.5	KABA BARA için / for ROUGH BORING HEADS
2715-M3x5	M3x0.5	5	1.5	KABA BARA için / for ROUGH BORING HEADS
2715-M3X8	M3x0.5	8	1.5	KABA BARA için / for ROUGH BORING HEADS
2702-M4X10	M4x0.7	10	2	KARTUŞ için / for CARTRIDGE
2702-M4X12	M4x0.7	12	2	KABA BARA için / for ROUGH BORING HEADS
2725-M5X10	M5x0.8	10	2.5	KARTUŞ için / for CARTRIDGE
2725-M5X12	M5x0.8	12	2.5	KABA BARA için / for ROUGH BORING HEADS
2725-M5X14	M5x0.8	14	2.5	KABA BARA için / for ROUGH BORING HEADS
2703-M6X16	M6x1	16	3	KABA BARA için / for ROUGH BORING HEADS
2704-M8X25	M8x1.25	25.9	4	KABA BARA için / for ROUGH BORING HEADS

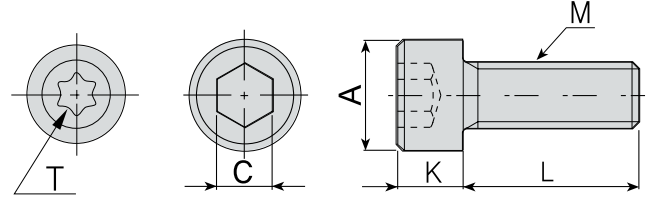

İNBUS CİVATALAR / INBUS SCREWS

Takım Kodu Ordering Code	M	A	C	K	L	Ürün Detayı Product Detail	
						KANAL KATERİ için / For GROOVING TOOLS	KANAL KATER VİDASI / SOME GROOVING TOOLS SCREW
2503-M4x10	M4x0.7	6.85	3	4	10	KANAL KATERİ için / For GROOVING TOOLS	KANAL KATER VİDASI / SOME GROOVING TOOLS SCREW
2525-M3X14	M3X0.5	5.4	2.5	2.9	14	BARA KARTUŞU için / for BORING HEADS CARTRIDGE	BARA KARTUŞU için SIKMA VİDASI / for BORING HEADS CARTRIDGE SCREW
2503-M4X20	M4x0.7	7	3	3.9	20	BARA KARTUŞU için / for BORING HEADS CARTRIDGE	BARA KARTUŞU için SIKMA VİDASI / for BORING HEADS CARTRIDGE SCREW
2503-M4X12	M4x0.7	6.85	3	4	12	KANAL KATERİ için / For GROOVING TOOLS	KANAL KATER VİDASI / SOME GROOVING TOOLS SCREW
2503-M4X15	M4x0.7	6.85	3	4	15	BARA KARTUŞU için / for BORING HEADS CARTRIDGE	BARA KARTUŞU için SIKMA VİDASI / for BORING HEADS CARTRIDGE SCREW
2504-M5X16	M5X0.8	8.5	4	5	16	KANAL KATERİ için / For GROOVING TOOLS	KANAL KATER VİDASI / SOME GROOVING TOOLS SCREW
2504-M5X12	M5X0.8	8.5	4	5	12	KANAL KATERİ için / For GROOVING TOOLS	KANAL KATER VİDASI / SOME GROOVING TOOLS SCREW
2504-M5X25	M5X0.8	8.5	4	5	25	BARA KARTUŞU için / for BORING HEADS CARTRIDGE	BARA KARTUŞU için SIKMA VİDASI / for BORING HEADS CARTRIDGE SCREW
2505-M6X16	M6X1	9.9	5	6	16	KANAL KATERİ için / For GROOVING TOOLS	KANAL KATER VİDASI / SOME GROOVING TOOLS SCREW
2505-M6X20	M6X1	9.9	5	6	20	KANAL KATERİ için / For GROOVING TOOLS	KANAL KATER VİDASI / SOME GROOVING TOOLS SCREW
2505-M6X25	M6X1	9.9	5	6	25	BLOK için / For BLOCK	BLOK BASKI PABUÇ VİDASI / for BLOCK CLAMP SCREW
2505-M6X30	M6X1	9.9	5	6	30	BARA KARTUŞU için / for BORING HEADS CARTRIDGE	BARA KARTUŞU için SIKMA VİDASI / for BORING HEADS CARTRIDGE SCREW
2406-M8X30	M8X1.25	11.6	6	8.1	30	FREZELEME TAKIMLARI için / for MILLING TOOLS	A16 MONTAJ VİDASI (KAFASI KÜÇÜK) / MOUNTING SCREW (SMALL HEAD)
2506-M8X20	M8X1.25	13	6	7.9	20	KARTUŞ için / for CARTRIDGE	KARTUŞ MONTAJ VİDASI / CARTRIDGE MOUNTING SCREW
2506-M8X30	M8X1.25	13	6	8.1	30	FREZELEME TAKIMLARI için / for MILLING TOOLS	A16 MONTAJ VİDASI / MOUNTING SCREW
2506-M8X35	M8X1.25	13	6	8.1	35	BARA KARTUŞU için / for BORING HEADS CARTRIDGE	BARA KARTUŞU için SIKMA VİDASI / for BORING HEADS CARTRIDGE SCREW
2406-M8X30	M8X1.25	15.75	6	6	30	FREZELEME TAKIMLARI için / for MILLING TOOLS	A16 MONTAJ VİDASI / MOUNTING SCREW
2408-M8X30	M8X1.25	13.9	8	10	30	FREZELEME TAKIMLARI için / for MILLING TOOLS	A16 MONTAJ VİDASI / MOUNTING SCREW
2407-M10X30	M10X1.5	16	7	6	30	FREZELEME TAKIMLARI için / for MILLING TOOLS	A22 MONTAJ VİDASI / MOUNTING SCREW
2408-M10X30	M10X1.5	13.90	8	10	30	FREZELEME TAKIMLARI için / for MILLING TOOLS	A22 MONTAJ VİDASI / MOUNTING SCREW
2510-M10X40	M10X1.5	16	10	10	40	FREZELEME TAKIMLARI için / for MILLING TOOLS	A22 MONTAJ VİDASI / MOUNTING SCREW
2508-M10X40	M10X1.5	16	8	10	40	BARA KARTUŞU için / for BORING HEADS CARTRIDGE	BARA KARTUŞU için SIKMA VİDASI / for BORING HEADS CARTRIDGE SCREWS
2408-M12X35	M12X1.75	18	8	7	35	FREZELEME TAKIMLARI için / for MILLING TOOLS	A27 MONTAJ VİDASI / MOUNTING SCREW
2510-M12X35	M12X1.75	18	10	12	35	FREZELEME TAKIMLARI için / for MILLING TOOLS	A27 MONTAJ VİDASI / MOUNTING SCREW
2514-M16X35	M16X2.0	23.7	14	16	35	FREZELEME TAKIMLARI için / for MILLING TOOLS	A32 MONTAJ VİDASI / MOUNTING SCREW
AAV-11-U5-40x4.5	UNC 5-40	5.4	T10	2.8	4.5	DİŞ AÇMA TAKIMLARI için / for THREADING TOOLS	16 ER/L, 16 IR/L ALTLIK VİDASI / SHIM SCREW
AAV-12-U8-32x5.5	UNC 8-32	6.7	T20	3.8	5.5	DİŞ AÇMA TAKIMLARI için / for THREADING TOOLS	22 ER/L, 22 IR/L ALTLIK VİDASI / SHIM SCREW
AAV-15-M5x5.7	M5X0.8	8.5	T20	3.15	5.7	DİŞ AÇMA TAKIMLARI için / for THREADING TOOLS	27 ER/L, 27 IR/L ALTLIK VİDASI / SHIM SCREW

SEKMAN / RING

Ürün Resmi Product Picture	Ürün Kodu Product Code	Ürün Detayı Product Detail
		ACS-01

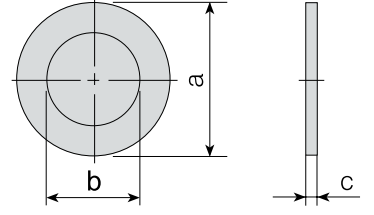

BASKI PULU / STAMP

Takım Kodu Ordering Code	BASKI PULU / STAMP			Ürün Detayı Product Detail	
	a	b	c		
ABPL-01	11	6.5	0.5	PUL / STAMP	BASKI PULU
ABPL-02	12.75	7.1	0.45	PUL / STAMP	BASKI PULU

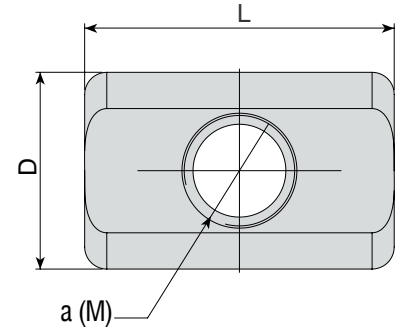



BARA PABUÇLARI / BORING HEADS CARTRIDGE

Takım Kodu Ordering Code	BARA PABUÇLARI / BORING HEADS CARTRIDGE			Ürün Detayı Product Detail	
	a (M)	D	L		
ABKS-D16	M3x0.5	4.9	6	KABA BARA için / for ROUGH BORING HEADS	ABHR-D16x42-W16-L90
ABKS-D20	M4x0.7	5.9	9	KABA BARA için / for ROUGH BORING HEADS	ABHR-D20x50-W20-L100
ABKS-D25	M4x0.7	5.9	12	KABA BARA için / for ROUGH BORING HEADS	ABHR-D25x60-W20-L110
ABKS-D32	M5x0.8	8.9	14	KABA BARA için / for ROUGH BORING HEADS	ABHR-D32x64-W25-L120
ABKS-D40	M6x1	10.9	18	KABA BARA için / for ROUGH BORING HEADS	ABHR-D40x80-W32-L140
ABKS-D50	M8x1.25	13.9	28	KABA BARA için / for ROUGH BORING HEADS	ABHR-D50x100-W32-L160
ABKS-D63	M10x1.5	15.9	35	KABA BARA için / for ROUGH BORING HEADS	ABHR-D63x80-W32-L140, ABHR-D63x130-W40-L200
ABKS-D80	M12x1.75	17.9	45	KABA BARA için / for ROUGH BORING HEADS	ABHR-D80x140-W40-L210, ABHR-D80x140-W40-L210 -B

Ürün Resmi Product Picture	KESME ve KANAL LAMA AÇMA BLOK PABUÇLARI / BLOCKS FOR PARTING AND DEEP GROOVING BLADES CLAMPS		
	Ürün Kodu Product Code	Ürün Detayı Product Detail	
	ABK-01	LAMA BLOĞU İçin For BLADE BLOCK	ALBU-20-26 BASKI PABUCU / CLAMP
	ABK-02	LAMA BLOĞU İçin For BLADE BLOCK	ALBU-25-26 BASKI PABUCU / CLAMP
	ABK-03	LAMA BLOĞU İçin For BLADE BLOCK	ALBU-20-32 BASKI PABUCU / CLAMP
	ABK-04	LAMA BLOĞU İçin For BLADE BLOCK	ALBU-25-32, ALBU-32-32 BASKI PABUCU / CLAMP

Ürün Resmi Product Picture	LAMA ANAHTARI / BLADE KEY	
	Ürün Kodu Product Code	Ürün Detayı Product Detail
	ALA-01	AKL LAMA ANAHTARI / for BLADE KEY

Ürün Resmi Product Picture	ALYAN ANAHTARLARI / ALLEN KEYS		
	Ürün Kodu Product Code	Ürün Detayı Product Detail	
	AAL-01-2	2 mm	ALYAN ANAHTARI / ALLEN KEYS
	AAL-02-2.5	2.5 mm	ALYAN ANAHTARI / ALLEN KEYS
	AAL-03-3	3 mm	ALYAN ANAHTARI / ALLEN KEYS
	AAL-05-4	4 mm	ALYAN ANAHTARI / ALLEN KEYS
	AAL-07-5	5 mm	ALYAN ANAHTARI / ALLEN KEYS
	AAL-08-6	6 mm	ALYAN ANAHTARI / ALLEN KEYS
	AAL-09-1.5	1.5 mm	ALYAN ANAHTARI / ALLEN KEYS

Ürün Resmi Product Picture	TORK ANAHTARLARI / TORX KEYS		
	Ürün Kodu Product Code	Ürün Detayı Product Detail	
	80-T06	T06 TORK ANAHTARI / TORX KEY	
	80-T07	T07 TORK ANAHTARI / TORX KEY	
	80-T08	T08 TORK ANAHTARI / TORX KEY	
	80-T10	T10 TORK ANAHTARI / TORX KEY	
	80-T15	T15 TORK ANAHTARI / TORX KEY	
	80-T20	T20 TORK ANAHTARI / TORX KEY	
	81-T15	T15 T-TİP TORK ANAHTARI / T-TYPE TORX KEY	
	81-T20	T20 T-TİP TORK ANAHTARI / T-TYPE TORX KEY	





